

See discussions, stats, and author profiles for this publication at: <https://www.researchgate.net/publication/328041989>

Conceptual Design for Sustainable Buildings Considering Energy Consumption Using Simulation and ANN

Thesis · October 2018

DOI: 10.13140/RG.2.2.34721.04960

CITATIONS

0

READS

209

7 authors, including:



Emad Elbeltagi

Mansoura University

73 PUBLICATIONS 1,878 CITATIONS

SEE PROFILE



Mahmoud Dawood

Mansoura University

7 PUBLICATIONS 80 CITATIONS

SEE PROFILE



Hossam Wefki

The British University in Egypt

2 PUBLICATIONS 11 CITATIONS

SEE PROFILE

Some of the authors of this publication are also working on these related projects:



Energy Saving [View project](#)



Mansoura University
Faculty of Engineering
Structural Engineering Department

Conceptual Design for Sustainable Buildings Considering Energy Consumption Using Simulation and ANN

A Thesis
Submitted in Partial Fulfillment for the Requirements of the
Doctor of Philosophy
in
Structural Engineering
(Construction Engineering and Management)

Submitted by

Hossam El-Din Wefki Ali

Under Supervision of

Prof. Emad Elbeltagi

Structural Engineering Dept.
Faculty of Engineering
Mansoura University

Prof. Saad Abdrabou

Structural Engineering Dept.
Faculty of Engineering
Mansoura University

Dr. Mahmoud Dawood

Structural Engineering Dept.
Faculty of Engineering
Mansoura University

Dr. Ahmed Ramzy

Mechanical Engineering Dept.
Faculty of Engineering
Mansoura University

2017



Thesis Summary () Library

General Administration Library

Faculty:	Engineering	Dep.:	Structural Engineering	General No.:
Name:	Hossam El Din Wefki Ali	Degree:	PhD in Structural Engineering	Date:

Thesis	Conceptual Design for Sustainable Buildings Considering Energy Consumption Using Simulation and ANN
Summary	
<p>Recently, there has been a high level of demand for sustainable design of buildings construction. The catalysts for such demand are rising energy costs and increasing environmental concerns. Therefore, it is important to evaluate building energy consumption, which is the key problem of building energy saving. This study proposes a strategy to select the optimum conceptual design for residential building that achieves the minimum energy consumption in New Cairo, Egypt by coupling parametric analysis, artificial neural network and genetic algorithm.</p> <p>The optimization scope focuses on the building envelope and simulation setting parameters that has significant impacts on the building performance considering energy consumption. The parametric analysis concept is used to create a mass box that represents the building in Rhino/Grasshopper, where the energy simulation settings are identified. The energy simulation performed in one platform, both simulation inputs and outputs are stored in Excel sheets automated to initiate energy consumption database. The developed database is used for learning and testing an Artificial Neural Network (ANN) model, which is used in energy usage predictions. In order to assess the predicted ability and validity of the developed ANN model, a sensitivity analysis is performed using the best network selected to determine the most effective parameters on energy consumption of residential buildings in Egypt. An optimization model is developed that integrates ANN model and Genetic Algorithm considering single objective function to obtain the most appropriate design.</p>	
Keywords	
Residential buildings, Energy Simulation, Conceptual design phase, Visualization, ANN, Optimization, Genetic Algorithms	

General Administration Library–Mansoura University– 60 Gomhoria street, Mansoura, Egypt.
Box 35516

URL: <http://www.mans.edu.eg>

Email: mucentrilib@mans.edu.eg

DEDICATION

To my family, the people whom I love most

To my Father, Mother, Brother and Sister

To my Wife, Daughter and Son

ACKNOWLEDGEMENTS

I am thankful to **Allah Almighty**, the most Gracious, who has guided me to complete this thesis. Peace and blessing of **Allah Almighty** be upon **His Prophet Mohamed SAW**. I would like to take this opportunity to thank all those who helped and assisted me in completing this thesis. I extend my deepest gratitude to my supervisors, **Prof. Emad Elbetagi, Prof. Saad Abdrabou, Dr. Mahmoud Dawood and Dr. Ahmed Ramzy** for their guidance, help, comments and revisions in improving this thesis.

Thanks also go to My Father for his encouragement. Without his guidance and help, this thesis could not be accomplished. I would like to thank all my family members for providing a pleasant and healthy working environment.

Last but not least, thanks to **Sara Khalifa** for her patience and support.

ABSTRACT

Recently, there has been a high level of demand for sustainable design of buildings. The catalysts for such demand are rising energy costs and increasing environmental concerns. Therefore, it is important to evaluate building energy consumption, which is the key problem of building energy saving. Building design is a very complex task, involving many parameters and conflicting objectives. In addition, designers suffer from the limitations of energy simulation tools during the early design stage that addresses buildings envelope and orientation. This study presents an approach, which integrates parametric energy simulation, the rapidity of evaluation of Artificial Neural Networks (ANNs) and the optimization power of Genetic Algorithms (GAs). A residential building model is developed by coupling parametric analysis and building energy modelling tools as a means of developing an energy consumption database. Based on the simulation database of energy consumption that accommodates the Egyptian context, ANN model is established to be used in the prediction of energy consumption. In addition, the ANN model is linked to GA model to minimize the building energy usage for the conceptual design of sustainable buildings. Also, this study proposes a strategy for visualized parametric energy analysis of buildings during the conceptual design phase. The parallel coordinate plot is used to visualize the database to allow decision makers to flexibly evaluate energy performance. The contribution of this study are: a generic model with parametric analysis of different parameters affecting energy consumption are considered (building dimensions, orientation, windows-to-wall ratio (WWR), wall type, roof type, SOG type, Glass U-Value, SGHC, VT, heating and cooling set points). Several random values for each parameter are generated, and then these parameters are analysed through a multiple simulation process and a new strategy for multidimensional data that allow designer to estimate energy

usage without reference to simulation and energy tools. In addition, the proposed workflow overcomes the interoperability problem by integrating the parametric modelling and building simulation engine in one platform using Rhinoceros and its packages tools. The approach facilitates and allows designers to select the most appropriate design that achieves minimum energy usage during early design stages with associated design parameters without no experience of simulation and optimization tools.

Keywords: Conceptual Design Phase, Parametric Design, Residential Buildings, Energy Consumption, Simulation, Visualization, Artificial Neural Network and Genetic Algorithms

TABLE OF CONTENTS

DEDICATION.....	i
ACKNOWLEDGEMENTS.....	ii
ABSTRACT	iii
TABLE OF CONTENTS	v
LIST OF FIGURES	x
LIST OF TABLES.....	xiii
Chapter 1 INTRODUCTION.....	1
1.1 OVERVIEW.....	1
1.2 PROBLEM STATEMENT	1
1.3 RESEARCH SCOPE AND OBJECTIVES	3
1.4 RESEARCH METHODOLOGY	4
1.5 THESIS ORGANIZATION	5
Chapter 2 LITERATURE REVIEW.....	7
2.1 INTRODUCTION.....	7
2.2 SUSTAINABLE BUILDINGS CONCEPT.....	7
2.3 SUSTAINABLE BUILDINGS RATING SYSTEM	9
2.4 SUSTAINABLE BUILDINGS IN EGYPT	11
2.5 APPROACHES TO SUSTAINABLE BUILDINGS CONCEPT.....	12
2.5.1 Indoor Environmental Quality	13
2.5.2 Material Efficiency	14
2.5.3 Energy Efficiency	15
2.6 SUSTAINABLE BUILDINGS DESIGN METHODS	16
2.6.1 The Empirical Rules	17

2.6.2	The Simulation Based Trial-and-Error Methods	17
2.6.3	Knowledge-Based Methods	18
2.6.4	Optimization Methods	18
2.7	BUILDINGS ENERGY CONSUMPTION	19
2.7.1	Engineering Methods	20
2.7.2	Statistical Methods.....	21
2.7.3	Artificial Neural Networks	21
2.8	PARAMETRIC ENERGY ANALYSIS	23
2.9	COMPUTATIONAL GENERATIVE DESIGN.....	25
2.9.1	Rhinoceros® 3d / Grasshopper	26
2.9.2	EnergyPlus, Performance Simulation Tool.....	29
2.10	SUSTAINABLE BUILDINGS DESIGN OPTIMIZATION.....	31
2.10.1	Optimization Model Components.....	31
2.10.2	Genetic Algorithms	32
2.11	DATA VISUALIZATION METHODS.....	34
2.12	APPROACHES USED IN SUSTAINABLE BUILDINGS DESIGNS.....	36
2.12.1	Residential Building Energy Modeling	36
2.12.2	Literature Review within Optimization	40
2.13	RESEARCH PURPOSE AND LIMITATIONS	43
2.14	SUMMARY AND CONCLUSIONS.....	44
Chapter 3	ENERGY PERFORMANCE MODELLING	47
3.1	INTRODUCTION.....	47
3.2	ENERGY MODELLING DURING CONCEPTUAL DESIGN	47
3.3	ENERGY DEMAND	48
3.3.1	Climate of the Surrounding.....	49
3.3.2	Indoor Climate and Function of the Building.....	50
3.3.3	Building Envelope	50
3.3.4	Heating and Ventilation System, Lighting, Appliances.....	51
3.4	BUILDINGS ENERGY ASSESSMENT.....	51

3.4.1 Buildings Energy Assessment through Standards	54
3.5 THERMAL PROPERTIES	56
3.6 BUILDING ENERGY CALCULATION METHODS.....	63
3.7 ENERGY PERFORMANCE SIMULATION	72
3.8 BASIC PRINCIPLES OF ENERGY SIMULATION.....	73
3.9 THERMAL SIMULATION ENGINE.....	75
3.10 SUMMARY AND CONCLUSIONS.....	78
Chapter 4 ENERGY CONSUMPTION PREDICTION FRAMEWORK	80
4.1 INTRODUCTION.....	80
4.2 ENERGY CONSUMPTION PREDICTION FRAMEWORK	80
4.3 PARAMETRIC SIMULATION IN DESIGN	82
4.4 BUILDINGS ENERGY MODELING.....	83
4.5 ENERGY SIMULATION WORKFLOW	88
4.5.1 Step 1: Construction Material Assembly	91
4.5.2 Step 2: Geometry	99
4.5.3 Step 3: Simulations	100
4.5.4 Step 4: Simulation Results	105
4.6 DATA VISUALIZATION	106
4.7 SUMMARY AND CONCLUSIONS.....	110
Chapter 5 ARTIFICIAL NEURAL NETWORK MODEL DEVELOPMENT	112
5.1 INTRODUCTION.....	112
5.2 ARTIFICIAL NEURAL NETWORK BACKGROUND	112
5.3 ARTIFICIAL NEURON	114
5.4 ACTIVATION FUNCTION	115
5.5 TYPES OF ARTIFICIAL NEURAL NETWORKS	116
5.6 LEARNING ALGORITHM.....	118

5.7 NEURAL NETWORK MODEL DEVELOPMENT	119
5.7.1 Training and Testing Pattern.....	121
5.7.2 Normalization of The Input and Output Data.....	121
5.7.3 Neural Network Setup.....	122
5.7.4 Network Training and Testing.....	126
5.8 DEVELOPMENT OF A PREDICTION MODEL.....	127
5.8.1 Development of the Initial Model.....	129
5.8.2 Optimization of the Initial Model	130
5.9 SENSITIVITY ANALYSIS.....	137
5.10 ANN USER INTERFACE	138
5.11 SUMMARY AND CONCLUSIONS.....	140
 Chapter 6 SUSTAINABLE BUILDING DESIGN OPTIMIZATION MODEL	 142
6.1 INTRODUCTION.....	142
6.2 CHARACTERISTICS OF THE OPTIMIZATION TECHNIQUES.....	142
6.3 OPTIMIZATION MODEL PARAMETERS.....	144
6.4 OPTIMIZATION MODEL WORKFLOW.....	145
6.4.1 Gene Representation	147
6.4.2 Population Size	147
6.4.3 Fitness Function.....	148
6.4.4 Genetic Operators	148
6.5 OPTIMIZATION MODEL IMPLEMENTATION	151
6.6 SUMMARY AND CONCLUSIONS.....	160
 Chapter 7 MODEL VALIDATION AND CASE STUDY APPLICATION.....	 161
7.1 INTRODUCTION.....	161
7.2 MODEL VERIFICATION.....	161
7.2.1 Mathematical Calculations by Hand.....	162
7.2.2 Thermal Energy Simulation by EnergyPlus	168
7.2.3 Using the ANN to Solve Example Application	169

7.3 CASE STUDY APPLICATIONS	170
7.4 MODEL VALIDATION	175
7.5 SUMMARY AND CONCLUSIONS.....	177
Chapter 8 CONCLUSIONS AND FUTURE RECOMMENDATIONS	179
8.1 INTRODUCTION.....	179
8.2 CONCLUSIONS	179
8.3 RECOMMENDATIONS FOR FUTURE WORK.....	182
REFERENCES	184
APPENDIX 1.....	196
APPENDIX 2.....	203
APPENDIX 3.....	209
APPENDIX 4.....	225

LIST OF FIGURES

Figure 2-1: Triple bottom line	8
Figure 2-2: General structure of neural network (Abu Jamous, 2013) ...	22
Figure 2-3: Traditional early design energy analysis process	24
Figure 2-4: Components and parameters in Grasshopper	27
Figure 2-5: Distributed model method (Negendahl, 2015)	29
Figure 2-6: Overall EnergyPlus structure (Crawley, et al., 2000).....	30
Figure 2-7: Genetic algorithms optimization problem flowchart.....	33
Figure 2-8: Parallel coordinate plot representative sample	35
Figure 3-1: Energy demand	49
Figure 3-2: Heat exchange through a building and its surroundings (Berisha & Dragusha, 2015).....	52
Figure 3-3: Thermal simulation flow paths of a building	53
Figure 3-4: Section through a daylight building in the tropics (Berisha & Dragusha, 2015).....	57
Figure 3-5: The radiant energy transfer	59
Figure 3-6: Energy flow through a window (Heidegger, 2013).....	60
Figure 3-7: One node thermal model (Heidegger, 2013)	65
Figure 3-8: General data flow of simulation engines	73
Figure 3-9: General architecture of energy simulation tools (Maile, et al., 2007)	76
Figure 4-1: Flowchart for the energy prediction framework.....	81
Figure 4-2: Building energy modeling components (AIA, 2012).....	84
Figure 4-3: Egypt's climatic zones classification map according to (EREC)	85
Figure 4-4: Building orientation.....	87
Figure 4-5: Software diagram.....	89
Figure 4-6: The proposed workflow diagram.....	90

Figure 4-7: Wall Type 1 components section.....	92
Figure 4-8: Wall Type 2 components section.....	93
Figure 4-9: Wall Type 3 components section.....	94
Figure 4-10: Roof Type 1 component section.....	95
Figure 4-11: Roof Type 2 component section.....	95
Figure 4-12: Slab on Grade Type 1 components section	96
Figure 4-13: Slab on Grade Type 2 components section	97
Figure 4-14: Gerilla material maker component	97
Figure 4-15: Construction assembly Gerilla component.....	98
Figure 4-16: Modeling the building geometry	98
Figure 4-17: Modeling the building windows	99
Figure 4-18: Simulation process DIVIA through Grasshopper definitions	104
Figure 4-19: Inputs and outputs simulation data	105
Figure 4-20: Schematic Parallel Coordinates implementation.....	108
Figure 4-21: Example of the developed energy consumption data visualization web-based application.....	109
Figure 5-1: Basic artificial neuron.....	115
Figure 5-2 Feed-forward artificial neural network.....	118
Figure 5-3: A systematic neural network model development process (Boussabaine, 1996)	120
Figure 5-4: Devlopmnet process of the proposed ANN model.....	127
Figure 5-5: Correlation between simulated energy and ANN prediction energy during testing process	132
Figure 5-6: Topology of the Optimum ANN Model.....	134
Figure 5-7: Correlation between simulated energy and ANN prediction during testing process	136
Figure 5-8: Sensitivity analysis of the proposed ANN model	137

Figure 5-9: VB interface for the energy consumption prediction model	139
.....	139
Figure 6-1: The building design optimization workflow	146
Figure 6-2: Solutions Representation Optimization Model	147
Figure 6-3: Multi-point crossover	150
Figure 6-4: Genetic algorithm pseudo code	152
Figure 6-5: Developed optimization VB application	153
Figure 6-6: Convergence for GA (Crossover 0.7) with 25 generations	157
Figure 6-7: Convergence for GA (Crossover 0.7) with 50 generations	157
Figure 6-8: Convergence for GA (Crossover 0.7) with 100 generations	158
.....	158
Figure 6-9: Convergence for GA (Crossover 0.9) with 25 generations	158
Figure 6-10: Convergence for GA (Crossover 0.9) with 50 generations	159
.....	159
Figure 6-11: Convergence for GA (Crossover 0.9) with 100 generations	159
.....	159
Figure 7-1: Grasshopper definition for solved example output	168
Figure 7-2: ANN model application for solved example	170
Figure 7-3: Isometric of residential building case study	171
Figure 7-4: Case study optimization process	173

LIST OF TABLES

Table 2-1: Green Pyramids Rating Categories	12
Table 2-2: Benefits of Sustainable Design (FEMP, 2015)	16
Table 2-3: Energy Prediction Methods Comparison (Zhao, 2011)	23
Table 3-1: Climatic data	49
Table 4-1: Levels of Modeling Elements and Inputs	84
Table 4-2: The Proprieties of Materials.....	91
Table 4-3: Parameters values.....	100
Table 4-4: Alternative Design Options.....	101
Table 4-5: Settings for Thermal Simulations.....	102
Table 4-6: Constant parameters for thermal simulations.....	103
Table 4-7: Variable parameters for thermal simulations	103
Table 5-1: Different activation functions characteristics	116
Table 5-2: The ANN model input and output parameters	128
Table 5-3: Initial ANN model components and values	130
Table 5-4: Experiments for ANN proposed transfer function.....	131
Table 5-5: Experiments to determine the Optimum ANN Architecture	133
Table 5-6: Interpretation of typical MAPE values	135
Table 6-1: Constraints of variables used for optimization	145
Table 6-2: GA control parameters sets	151
Table 6-3: Optimization model parameter sets.....	154
Table 6-4: Values of objective function for best solution	155
Table 6-5: The optimum design values	156
Table 7-1 Solved example glass properties	166
Table 7-2 Characteristics of the case study building.....	171
Table 7-3: Alternative designs options	172
Table 7-4: Design options simulation results using EnergyPlus	174
Table 7-5: The optimum design for case study	175

Table 7-6: Conversion of grades.....	177
Table 7-7: Results of system validation.....	177

Chapter 1 INTRODUCTION

1.1 OVERVIEW

Climate change is possibly the greatest challenge facing humanity. With growing evidence that the phenomena of global warming and climate change are caused by anthropogenic greenhouse gas emission. It has been estimated that around a half of total carbon-related emissions typically come from buildings and their use (HBRC, 2005). So, it has become necessary to take immediate action to avoid dangerous consequences affecting future generations. Today, there is a high level of demand for sustainable/green buildings. A sustainable building is the outcome of energy efficient, resource efficient and environmentally responsible building which incorporates planning, design, construction and operational practices that significantly reduce or eliminate its negative impact on the environment. Sustainable buildings will be an indispensable alternative in the construction industry. The most important decisions regarding a building's sustainable features are made during the early design stages. However, it is a difficult task to find better design alternatives and construction method satisfying several conflicting criteria especially, economic and environmental performance. Selecting the most appropriate sustainable design is a key for successful building completion that accommodates sustainability requirements. The selection process depends mainly upon multidisciplinary analysis methods and optimization models. Therefore, these models have to be developed to facilitate decision-making process during early design stages for sustainable building design.

1.2 PROBLEM STATEMENT

For the past two decades, the Egyptian government has worked feverishly to improve building energy efficiency and address greenhouse gas emissions.

The motivation for this effort has been the realization that population momentum would ultimately place enormous demands on all sectors of the Egyptian state and that these demands would have the potential to dramatically limit long-term growth of the Egyptian economy. As reaction to this trend, the Egyptian authorities declared the commencement of its projects towards the use of more energy efficient levels, which aims to ensure the reduction of energy consumption. The explicit gap to be addressed within this research is to promote sustainable building design in Egypt. Such gap results from the following aspects:

- Environmental challenges
- Lack of Egyptian environmental awareness
- Scarcity of resources
- Rising energy costs
- Available information is incomplete or outdated
- Limited use of energy simulation tools
- Lack of Egyptian climate analysis
- Interoperability between modelling and simulation tools
- No formal representative reference model
- Limitations of sustainable buildings design research and tools

Furthermore, the building energy configuration selection is based on designers and modellers experience with limited number of green design options during the early design stages. Therefore, experience has to be documented, stored and visualized in database system and optimization model for a generalized usage. Moreover, the successful design related energy issues requires that special attention be paid to the early design stage when many potential design alternatives are generated and roughly evaluated in order to obtain the most promising design. Such models facilitate the decision process in early design

phase, which have considerable impacts on building performance including the environmental aspects.

1.3 RESEARCH SCOPE AND OBJECTIVES

This research is concerned with improving the current optimization methodologies, in order to make the optimization process more applicable for sustainable building design in Egypt. The work is based on a methodology, which combines artificial neural networks and genetic algorithms to enable fast and accurate optimization. This methodology is improved by a better handling of parametric building design methodology. An easy comprehensive framework is proposed to be adopted for buildings envelope design with minimum energy consumption. A generic model is developed based on the framework to prove its applicability and comprehensiveness. In details, objectives of this research are:

1. Develop a framework for selecting the most appropriate building envelope design that achieves the minimum energy usage.
2. Propose a workflow automatically converting building envelope model into multiple consistent thermal analytical models; coordination/integration of analysis inputs and outputs.
3. Generate energy consumption database integrating different construction envelope components (Walls type, Slab on Grade and Roof type) and evaluate their performance with respect to other parameters.
4. Present a visualization strategy for the estimating energy consumption database, to facilitate figuring out the predicted energy usage.
5. Develop a comprehensive tool for energy consumption prediction using Artificial Neural Networks with friendly user interface.

6. Developed a generic model for sustainable building that provides an optimum sustainable building envelope design. The model should respect some user design preferences.

1.4 RESEARCH METHODOLOGY

The methodology followed in this study can be summarized as follows:

1. Perform a comprehensive review of literature on sustainability that applies to buildings design.
2. Sufficiently review the previous work on buildings energy analysis, including methods used for design and prediction.
3. Introduce the parametric energy analysis, artificial neural networks and genetic algorithms.
4. Review the construction material including thermal and technical proprieties of individual envelope elements used in sustainable buildings in Egypt.
5. Construct parametric energy modelling using parametric modelling design tool (Grasshopper).
6. Integrate the parametric model with energy simulation engine (EnergyPlus) under one platform (Rhinceros 3D).
7. Gather the simulation analysis results using Excel in order to generate the energy consumption database.
8. Visualize the results using Parallel Coordinate Plot technique to easily allow designer access the multidimensional data.
9. Develop an Artificial Neural Network (ANN) model for energy prediction.
10. Develop an optimization model that interacts with the successful ANN model to test alternative building energy performance parameters.

11. Identify the objective function, variables and constraints for optimization model.
12. Develop a computer system based on the previous development to facilitate the use of the developed model.

1.5 THESIS ORGANIZATION

This section outlines the various sections of the study contents. The first chapter is an introduction, which gives a brief background about the topic and a problem statement. In this chapter the research objectives are presented, the methodology is outlined.

- Chapter 2 of this study discusses past research and studies that are related to the sustainable building design, analysis and optimization available tools. In addition, a review of literature regarding the history of sustainable development, building design concepts and techniques, approaches towards sustainable building in Egypt, building energy consumption, parametric energy analysis and an introduction to Artificial Neural Networks and Genetic Algorithms.
- Chapter 3 highlights building design and performance concepts through heat transfer and introduces the calculation methods, energy simulation tools and legislation behind the energy performance of residential buildings. Then, the parametric design theory and its role in energy performance is discussed and demonstrated.
- Chapter 4 introduces the proposed framework, which consists of three phases. First phase illustrated outlines the design steps of the proposed parametric workflow. That is used to generate the energy consumption database among different design parameters automatically by

integrating modelling software and energy simulation tools. The visualization strategy is provided and outlined. Chapter 5 presents the development of energy consumption prediction ANN model, which represents the second phase of the proposed framework. This chapter focuses on choosing the best network structure, training methods and ANN model validation and sensitivity analysis of the proposed ANN model. In addition, it presents a user-friendly interface for the ANN model. Chapter 6 presents third phase of the framework that outlines the proposed approach and methodology used to develop the sustainable building design optimization model. Chapter 7 introduces the models verification and validation carried out using solved example and actual case study. Finally, the conclusion and finding of the whole work is summarized in chapter 8. Further recommendations for future research and work continuation are high-lightened.

Chapter 2 LITERATURE REVIEW

2.1 INTRODUCTION

This chapter covers a comprehensive literature review on sustainable building concept, sustainable buildings international rating systems and the green buildings in Egypt. After that, it presents a brief description of the concepts and design methods for sustainable buildings. Previous building energy consumption methods are discussed. An introduction to parametric energy analysis and its platform tools as a powerful of generating, coupling the design tools with thermal/energy tools. The advantages of using Genetic Algorithms in optimization process are discussed. Finally, previous approaches for sustainable buildings design, optimization, modelling and simulation are reviewed.

2.2 SUSTAINABLE BUILDINGS CONCEPT

Recently, sustainability is quickly becoming the main concern of our era due to rapid world population growth, with the continued pollution and the increased demand for scarce resources. Sustainable or green buildings have attracted developed and developing countries attention from both practitioners and researchers. In this time of rapidly rising energy consumption and costs, the U.S building sector consumed about 40% of total energy consumption and 38% of the CO₂ emissions. In addition, the residential and commercial buildings in Europe account for 37.7% of the total energy consumption (Habibi, 2017).

The American Institute of Architects (AIA) defined sustainability as “the ability of society to continue functioning into the future without being forced into decline through exhaustion or overloading of the key resources on which that system depends”. In general, there is no consensus on sustainable

construction meaning, although in the construction field, the common definition of sustainability is the “provision of buildings designed to employ less virgin material and energy, and generate less carbon dioxide and waste; techniques and methods of design that promote a sustainable model of livelihood through the entire built environment in accordance with the principal of triple-bottom-line strategy” (Umar, et al., 2016).

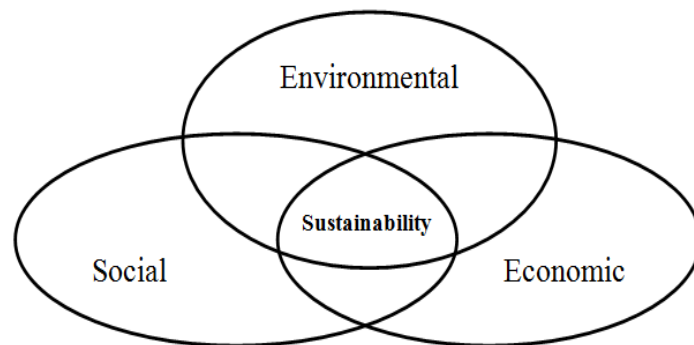

Figure 2-1: Triple bottom line (Umar, et al., 2016)

ElKington (1998) stated the idea of “the triple bottom line”: economic, social and environmental aspects which represents the sustainable approach to work, see Figure 2-1. The main goal of sustainable construction is to improve the whole building performance, reduce the environment effects and minimize the costs. The Hong Kong Housing Authority (HKHA, 2005) presents sustainable construction as follows:

- ***Environmental sustainability***: to build, maintain and operate the buildings with best utilization of natural resources and minimize environmental impacts.
- ***Social sustainability***: to provide nature social cohesion, safe and healthy environment to all construction stakeholders in addition building end-users.

- ***Economic sustainability***: to build cost effectively, retain operating costs low, extend building service life cycle and apply the control by best utilization for existing stock.

2.3 SUSTAINABLE BUILDINGS RATING SYSTEM

With increased emphasis on sustainable building design, many countries and international organizations have initiated respective rating systems for sustainable construction to measure the sustainability level of green buildings. Currently, a number of different rating systems are used to rate the environmental performance of buildings. Most of these rating systems' primary criteria are similar in that they evaluate a building's energy consumption, water efficiency, material use and indoor environmental quality. These systems have been employed as the essential instruments for achieving buildings sustainability and evaluating buildings performance. Most developed countries as United Kingdom, Japan, United States, Hong Kong and Singapore have developed rating systems for buildings sustainability, which are BREEAM, CASBEE and LEED respectively (He, et al., 2017).

- **BREEAM**

Building Research Establishment Environmental Assessment Methods (BREEAM) was developed in United Kingdom by the Building Research Establishment Limited (BRE) in 1990 (Bunz, et al., 2006). It provides a guidance as a reference of the design/procurement checklist and operation/management checklist for new and existing buildings respectively. Checklist includes evaluation items; which credits are awarded to each item regarding its performance. The credits summation produces a single overall score that could be rated by referring it on a scale of Pass, Good, Very Good or Excellent.

- **LEED**

Leadership in Energy and Environmental Design (LEED) was developed in the United States of America in 1998 by the U.S. Green Building Council (LEED, 2016). It provides a guidance reference with checklists during design and construction phases. A single overall score calculated by adding the credits awarded to each item regarding their performance. The final assessment of building is rated based on the overall score on a scale of Certified, Silver, Gold and Platinum.

The aspects constitute the foundation for the previous sustainable design guidelines and green buildings rating systems developed at the United Nations conference in Rio de Janeiro-Brazil presented the importance of sustainability with great emphasis on the construction industry. Agenda 22 mainly included the following aspects (Assad, 2011):

- Regulation of energy-efficient design principles.
- International information exchange of construction related aspects to the environment.
- The promotion for use of efficient materials.
- Methods to encourage and facilitate recycling and reuse of building materials.
- Financial penalties to discourage the use of materials that damage the environment.
- Encouraging the use of “clean technologies”.

- **CASBEE**

Comprehensive Assessment System for Building Environmental Efficiency (CASBEE) was developed by the Japan Sustainable Building Consortium in 2001 (CASBEE, 2016). It is a rating and weighting tool provides a reference manual for self-assessment using Excel 2000. The tool has been developed to allow simple data entry includes categories in a form of checklist, each

category is scored from level 1 (minimum sustainability requirements) to level 5 (high level of achievement). The assessment output is presented in five levels: C, B-, B+, A and S, where C point toward poor and S for excellent.

2.4 SUSTAINABLE BUILDINGS IN EGYPT

Many historic buildings included the features of sustainability that returned to the adhering climate and site layout, which were constructed before the evolvement of the term “sustainable/green”. For example, the Giza Pyramids in Egypt are considered to be the oldest sustainable structure in the world for the following reasons (EGBC, 2015): sustainable structural system; using the natural for construction materials, lighting, ventilation systems; durability with minimum maintenance; and harmony with surrounding environment. Recently, the Egyptian authorities have worked feverishly to evaluate sustainable buildings and to improve building energy efficiency which the key problem of energy saving (Hanna, 2013). To meet the fast growing energy demand, Egyptian Government is paying a great attention to all activities related to production, energy codes and rating systems aiming to secure availability and sustainability of buildings as cost effective means to energy saving, indoor thermal comfort and protect the surrounding environment.

The Egyptian Housing Building National Research Centre (HBRC) introduced Residential and Commercial Energy Efficiency Building Codes (EEBC) (HBRC, 2005). The code stated the energy performance requirements with the minimum and maximum allowable U-values or R-values for the building envelope elements. Moreover, the envelope represents the external skin of building which includes wall, roof, insulation, windows that have great effects on building energy performance. In addition, it specified the properties of glazing for the maximum allowable U-value and Solar Heat Gain Coefficient (SHGC) for glass.

In addition, the HBRC established the Egyptian Green Building Council (EGBC) in 2009, which developed the Egyptian Green Pyramid Rating System (EGPRS) for sustainable building assessment in 2011. It was created to fill the need for an Egyptian sustainable building rating system, and to localize the experience of other countries based on LEED rating system to assess new buildings at the design phase (AbdelAzim, et al., 2016). In order to proceed in assessment, process the building design should first meet and comply with design national codes requirements. The rating is divided into seven categories as listed in Table 2-1.

Table 2-1: Green Pyramids Rating Categories

Category	Score	Ratio (%)
Sustainable site	15	14 %
Energy efficiency	25	24 %
Water-use efficiency	30	29 %
Materials and sources	10	10 %
Indoor environmental quality	10	10 %
Management	10	10 %
Innovation	3	3 %
Total	103 (3 bounce)	100 %

The final score is used to rate the projects reference to the scale of: (40-49 points) certified, (50-59 points) Silver Pyramid, (60-79 points) Gold Pyramid and (80 or more points) Green Pyramid, which indicates that the ultimate goal of EGPRS is “reaching green”.

2.5 APPROACHES TO SUSTAINABLE BUILDINGS CONCEPT

Once owner conceived the project, the engineer is consulted to develop the concept in the earliest design stage; schematic drawings, which basically

consist of building: plans, sections and elevations. Decision regarding the building type, dimensions, form, materials and occupancy, etc. are made during the earliest stages of design. The building construction and maintenance quality, performance and cost could be impacted by any decisions made in the early design stage. The building envelope plays an important role to maintain the quality of indoor environment from the outdoor weather conditions fluctuation. In addition, the building envelope construction material (10%-20% of total building cost) selection has a significant impact on the building energy performance and the energy cost (Gowri, 1990).

Typically, the design of the building envelope components involves many considerations that it must be strong enough to meet a number of performance requirements relating to:

- Indoor Environmental Quality
- Material Efficiency
- Energy Efficiency

2.5.1 Indoor Environmental Quality

Buildings' occupants spend nearly ninety percent of their times inside buildings. From here comes the great importance of Indoor Environmental Quality (IEQ) to the health and productivity of building occupants. IEQ encompasses indoor air quality, thermal comfort, daylighting, acoustics and views to the outdoors. Addressed mainly during the design and construction phases, these issues need to be carefully considered in the building ongoing operations a maintenance process. Thermal comfort is considered as one of the most essential operational issues affect buildings indoor quality. Consequently, any assessment tool used to evaluate the building efficiency needs to consider the criterion of thermal comfort as the context of its

evaluation for the building performance. Thermal comfort is defined as “that condition of mind which expresses satisfaction with the thermal environment and that it changes from one person to another based on his/her region, culture, background, personal preferences, performed activities, clothing and state of mind” (Rohles Jr., 2007).

On the other hand, natural lighting is very important to visual comfort in buildings to ensure the condition of indoor quality. Daylighting is the practice of obtaining light into a building interior and distributing it in a way that provides more desirable and better quality illumination than artificial light sources. Further, this reduces the need for electrical light sources, thus cutting down on electricity use and its associated costs and pollution (Reffat, 2004). Although the design of Indoor Quality is difficult as it changes from one user to another, it is considered an essential sustainable building issue. For instance, daylighting creates a better environment than artificial lighting systems and reduces energy consumption and building operation costs from 30% to 40 % savings of building’s total energy by minimizing the internal heating, cooling and lighting loads (Assad, 2011).

2.5.2 Material Efficiency

The expected depletion of resources at a certain stage would inevitably occur with the unprecedented growth in demand for raw materials, while the world consumes about 10 billion tons of engineering material annually. Most materials are derived from minerals, which are of finite magnitude (Assad, 2011). Therefore, minimizing the use of materials is a must by utilizing green materials to achieve resource efficiency. The green building material is an ecological, healthy, recycled and high performance building material that is capable of efficiently minimizing impacts to surrounding environment and

damage to human health during its entire life cycle including resources exploitation, manufacturing, application, utilization, disposal and recycling.

2.5.3 Energy Efficiency

Several design features can affect the energy efficiency of building envelopes, including the shape of the building, wall and roof construction, foundation type, insulation levels, window type and area, thermal mass, and shading. For a given floor area, determining the envelope configuration that results in minimum annual energy consumption can be a challenging task, but ultimately not very useful, since economic considerations must play a role in the construction of any real building. Indeed, the problem of energy efficiency becomes more complex as economic factors are introduced.

A building that consumes the absolute minimum amount of energy for its size is most likely not very cost-effective, since additional construction costs would overwhelm any savings from reduced energy use. Therefore, a balance must be found between increases in capital cost and recurring annual savings. The potential energy conservation could be maintained through many means. Some of which are: designing the building insulation, addressing the building orientation, considering the building shape and taking into account passive solar techniques and cooling and heating loads requirements for thermal comfort (Assad, 2011).

For sustainable buildings design to be successful, the benefits of designing them must be known to those purchasing construction services and facilities. Because sustainability addresses a broad range of economic, environmental, and social issues, the benefits of sustainable design are potentially enormous. A list of these benefits recently published by the Federal Energy Management Program (FEMP, 2015) that provides an overview of the promise of a shift to

sustainable design. Table 2-2 listed the benefits of sustainable buildings design.

Table 2-2: Benefits of Sustainable Design (FEMP, 2015)

	Economic	Social	Environmental
Indoor Environmental Quality	Higher productivity, lower incidence of absenteeism, reduced staff turnover, lower insurance costs, reduced litigation	Reduced adverse health impacts, improved occupant comfort and satisfaction, better individual productivity	Better indoor air quality, including reduced emissions of volatile organic compounds, carbon dioxide, and carbon monoxide
Materials and Resources	Decreased first costs for reused and recycled materials, lower waste disposal costs, reduced replacement costs for durable materials, reduced need for new landfills	Fewer landfills, greater markets for environmental preferable products, decreased traffic due to the use of local/regional materials	Reduced strain on landfills, reduced use of virgin resources, better managed forests, lower transportation, energy and pollution, increase in recycling markets
Energy Efficiency	Lower first costs, lower fuel and electricity costs, reduced peak power demand, reduced demand for new energy infrastructure	Improved comfort conditions for occupants, fewer new power plants and transmission lines	Lower electricity and fossil fuel use, less air pollution and fewer carbon dioxide emissions, lowered impacts from fossil fuel production and distribution

2.6 SUSTAINABLE BUILDINGS DESIGN METHODS

A basic principle of sustainable building design is to reduce the negative impacts on the building construction environment while taking cost and other performance criteria into account. This principle is implemented in previous studies through four methods: the empirical rules, the simulation based trial-

and-error methods, the knowledge-based methods and the optimization methods (Wang, 2005).

2.6.1 The Empirical Rules

The empirical rules or guidelines based on manual methods are considered a general statement, tables or diagrams that can be used as a guidance to facilitate decision making for good design. Some general rules such as “place the most windows on the south side and fewest on the north side to maximize solar gain and reduce heat loss” are obvious and easy to implement in the design process (Wang, 2005).

- Guidelines are generated statement, tables or diagrams that can guide decision making for good design.
- There is no need for calculations.
- It can be quickly and easily applied at the initial building formulation stage.
- They provide a shortcut to achieve a design alternative with good performance.

2.6.2 The Simulation Based Trial-and-Error Methods

Because of the large design space, designers may explore only a few design alternatives after several trials. Many potentially better design alternatives are missed. Therefore, the simulation-based trial-and-error methods are inefficient to explore the design space. This means that simulation programs are typically used when the design has become fixed.

- Building simulations are unique because of their ability to consider the slight relationships between many performance-related features.
- They can be used to study the impact of design parameters on the considered performance criterion.

- The designers must manually explore the design space for a better building design.
- After a design alternative is defined, simulation programs are applied to evaluate its performance.
- Some design parameters are modified, and simulation programs are used again to get the performance for the modified alternative.

2.6.3 Knowledge-Based Methods

Knowledge-based systems (KBS) are computer software embodies a collection of knowledge, facts, and rules that are similar to what a human might employ to solve a particular problem. Many expert systems have been prototyped in the field of HVAC systems and energy-efficient buildings design. Two approaches can be identified in previous KBS applications:

- The first approach, heuristics extracted from human experience is used to speed up the process of finding a satisfactory solution and to provide assistance to designers
- The second approach, integrates heuristic knowledge and procedural simulation programs. This approach has been implemented in a number of knowledge-based systems.

To conclude that the integration between simulation and KBS provide an effective assistance to designers in energy-efficient buildings design because suggestions are provided in both qualitative and quantitative forms.

2.6.4 Optimization Methods

Optimization method aims at finding an optimal design that meet potentially conflicting design requirements such as minimizing environmental impact while also minimizing development costs and at the same time respecting some predefined performance criteria.

There are many difficulties in applying optimization to building design. These difficulties can be seen in terms of the following aspects:

- The design space is typically large.
- The interactions among parameters are complicated and there is more than one-performance criterion to be considered.
- The evaluation process of performance criteria of design alternative usually done by different commercial simulation programs.
- There is a difficulty to couple the simulation programs to an optimization models.

2.7 BUILDINGS ENERGY CONSUMPTION

Buildings are large consumers of energy and therefore prime candidates for conservation activities. The energy performance in buildings is affected by numerous factors, such as surrounding weather conditions, building envelope and characteristics (size, floor plan and number of windows), occupancy and their behaviours, the operation of sub-level components like Heating, Ventilation and Air-Conditioning (HVAC) system (Biswas, et al., 2016). The building envelope is a determining factor in the consumption of energy in most buildings and the selection of its components can significantly influence the thermal performance. The prediction of energy use in buildings is therefore significant for improving its energy performance, leading to energy conservation and reducing environmental impact.

The energy system in buildings is quite complex, as energy types and buildings types vary greatly. The main energy forms considered are heating, cooling, lighting and plugin equipment's loads. The most frequently considered building type are residential and office buildings, varying from small rooms to big estates. Due to the complexity of the problem, precise

consumption prediction is quite difficult. The methods used in this application include engineering, statistical and artificial intelligence methods (Abu Bakar, et al., 2015):

2.7.1 Engineering Methods

Engineering methods estimate thermal dynamic and energy consumption on the whole building using physical principles which developed adequately over past fifty years. It can be categorized into two methods, detailed comprehensive methods and simplified methods. Detailed comprehensive (elaborate) methods use detailed thermal dynamic or physical functions for all components of the building energy consumption accurately, step-by-step taking into consideration climate conditions, building characteristics, occupant schedules and HVAC system. Many standards have been developed for the calculation of energy consumption; heating, cooling, lighting loads for the whole building. In addition, there are hundreds of tools used for developing building energy standards and analysing energy consumption. The U.S. Department of Energy (DOE) maintains a list of almost building energy software tools for energy simulation (Zhao & Magoulès, 2012) .

Although, these simulation tools are based on physical principles to obtain effective and accurate simulation, there are some difficulties that the simulation process requires detailed parameters input data. Consequently, these parameters are always difficult to obtain and unavailable to many organizations. This lack of precise inputs will affect the accuracy of the simulation process. Therefore, some studies proposed a number of simplified models, which can be applied. There are no clear outlines between detailed and simplified methods. In addition, it is possible to perform a simplified simulation with some comprehensive tools (EnergyPlus), if the purpose is to compare alternatives or systems. For detailed building energy analysis,

detailed methods might be sufficient and more comprehensive tools will be more appropriate (Zhao, 2011).

2.7.2 Statistical Methods

Statistical regression models are also known as empirical methods which simply correlate energy index or parameters of building energy consumption with the influencing variables. They are developed based on historical performance data. Therefore, there is a need to collect enough and sufficient historical performance data before utilizing the models. Many studies on regression models has been carried out to (Zhao, 2011):

- Predict the energy consumption using simplified variables.
- Predict some energy index.
- Estimate parameters for energy consumption.

2.7.3 Artificial Neural Networks

Artificial Neural Networks (ANN) is the most used artificial intelligence methods in building predict energy consumption prediction. Many good results in real applications have been achieved using the ANN models (Abu Bakar, et al., 2015). The previous studies have applied ANNs for various types of buildings energy consumption in a number of variables such as cooling/heating loads, electricity usage, estimation of usage parameters and sub-level components operation and optimization.

ANN is not an optimization method by itself. It is an adaptable approach which can be applied to any kind of systems, supported by either regression or classification techniques. ANN have been developed to generalize the nervous system of a human being into one or more mathematical models. An ANN is aimed to provide fast and accurate approximation of a given system, based on a set of inputs and outputs. ANN have been widely and successfully used in a

number of engineering studies due to significant advancement in technology to solve challenging problems with higher computing capacity (Biswas, et al., 2016).

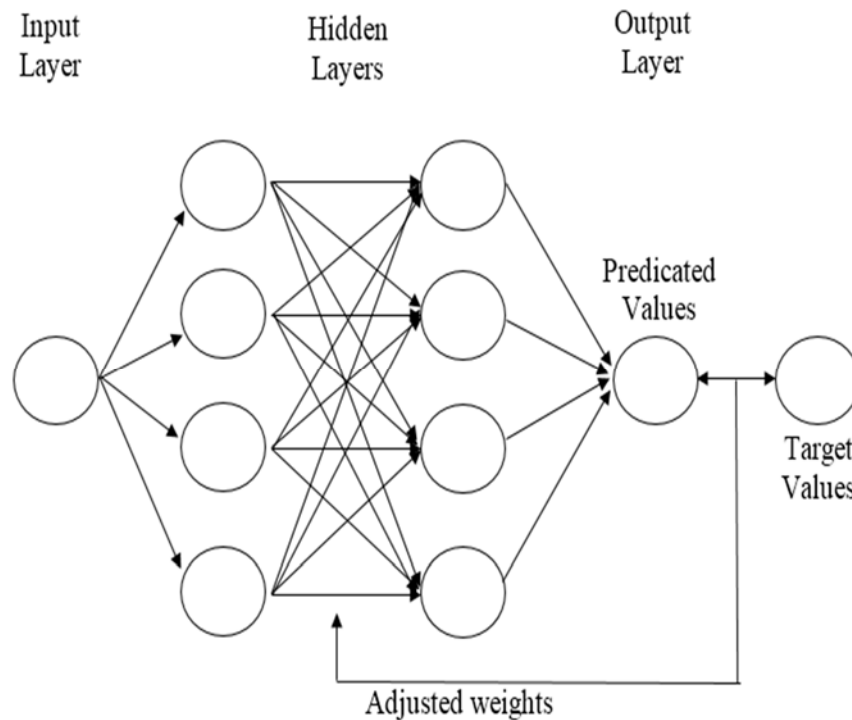

Figure 2-2: General structure of neural network (Abu Jamous, 2013)

Figure 2-2 illustrates the general structure of artificial network as a series of interconnected processing elements (artificial neurons) in a number of layers. In regression technique, the outputs represent some desired, continuously valued transformation of the input patterns. In classification, the objective is to assign the input patterns to one of several categories or classes, usually represented by outputs restricted to lie in the range from 0 to 1 or, which represent the probability of class membership. ANN consists of a pool of simple processing elements, which communicate by sending signals to each other over a large number of weighted connections.

The comparative analysis of the commonly used models for building energy consumption prediction is summarized in Table 2-3.

Table 2-3: Energy Prediction Methods Comparison (Zhao, 2011)

Methods	Inputs needed	Running speed	Easy to use	Model complexity	Accuracy
Elaborate Engineering	Detailed	Low	NO	Fairly high	Fairly high
Simplified Engineering	Simplified	High	Yes	High	High
Statistical	Historical data	Fairly high	Yes	Fair	Fair
ANNs	Historical data	High	NO	High	High

2.8 PARAMETRIC ENERGY ANALYSIS

In the early design stages, there is an increasingly important needs for energy efficient building design. In addition, there is increasing demand for greater accuracy and better energy analysis results. One developing technique for achieving these increasing demands is parametric energy analysis (Pratt & Bosworth, 2011).

Commonly, current sustainable design processes can be classified into two stages. In the first stage, the architect develops numerous combinations of different building options for producing a schematic design that attains low combined of heating, cooling and lighting loads. Coupling both, architectural and mechanical systems are specified and optimized in the second stage of design process. The design space is constructed in the first stage; therefore, most critical stages of design is proscribing much of the work that follows. In parametric energy analysis, rather than analysing a mere handful of design options, the designer produced the design space constrained by the fact that commonly used computer aided design tools by utilizing various parameters of energy analysis to generate a wide range of highly design combinations.

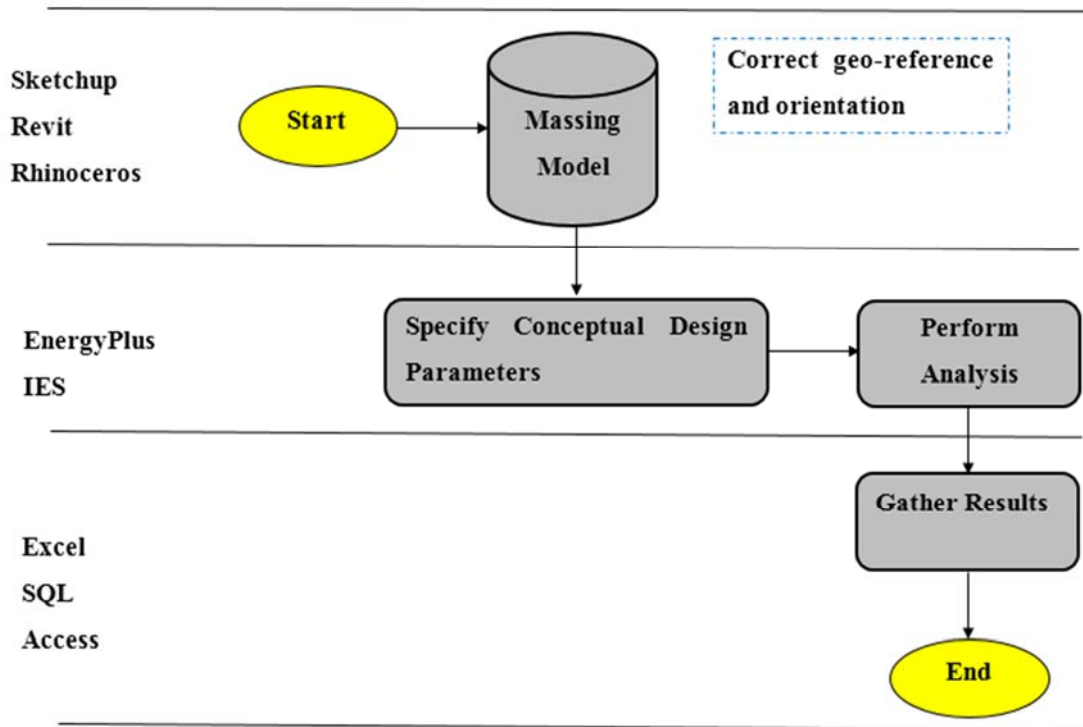

Figure 2-3: Traditional early design energy analysis process

The needs of energy consumption were balanced against the need for adequate natural lighting, visual connections with the outdoors, occupant comfort and programmatic space configuration requirements. Energy analysis simulations used to provide guidance to the design team as they sought to meet these goals. The typical early design energy analysis process is shown in Figure 2-3. This process is typically performed for a few design options, two or three, and the insights gained are used to inform the further development of the design while taking into account the requirements of energy use. It involves:

- Creating a massing model, locating it at the correct geo-referenced location and orienting it according to the design intent. The massing is created in design modelling software like Sketchup, Revit or Rhinoceros.
- Specifying conceptual design parameters like conceptual construction assemblies, glazing ratios, occupancy schedules and mechanical

systems. This is achieved in energy analysis tools like EnergyPlus or IES Virtual Environment.

- Performing the energy analysis, gathering and interpreting the reported outputs. This is accomplished by using database tools such Microsoft Excel, SQL or Access.

2.9 COMPUTATIONAL GENERATIVE DESIGN

Recently, Computational Generative Design or Parametric Modelling is considered a valuable tool with an emerging trend in architecture design, which is used to explore and enrich the potential of architecture design process considering building energy efficiency. Parametric Design is defined as “A process based on algorithmic thinking that enables the expression of parameters and rules that, together, define, encode and clarify the relationship between design intent and design response”. This method gives the designer a full dynamic control over building geometry and components to find the most appropriate solutions on complex problems with the charge of various alternatives at the same time (Touloupaki & Theodosiou, 2016).

The design using graphical/visual coding tools, such as Grasshopper for Rhinoceros®, which give the opportunity to perform parametric design concepts with the powerful of visual programming capabilities thus automating complex tasks. In addition, to implement the parametric design with energy performance-based design using simulation software, which facilitates the design process at any given point. EnergyPlus is considered a popular program for building energy simulation. However, the parallel use of both parametric and performance based methods can lead to tiresome iterative cycle of model-simulate-evaluate-remodel. The interoperability between building modelling and energy simulation tools may limit the depth of

exploration within the design space (Santos, et al., 2017). Different types of Performance-based Generative Design Systems (PGDSs) have been proposed to overcome these limitations. These systems integrate different modules as follows:

- Parametric model used for generating a various design options based on algorithmic processes procedural rules.
- Energy simulation engine to assess each design option generated by the parametric model.
- Methodology that automatically directs the iteration process until it finds the best solution.

Lately, several modelling software with energy simulation packages have emerged, which facilitate the process of sustainable building design. Consequently, it is probable to develop the framework for parametric modelling energy based by either coupling DIVA for Rhinoceros with Grasshopper definitions and parametric design methods or other Grasshopper-based energy simulation packages.

2.9.1 Rhinoceros[®] 3d / Grasshopper

Commonly, Rhino[®] is referred to Rhinoceros[®] 3D, that is a 3D computer aided design (CAD) modelling tool used as a free from Non-Uniform Rational Basis Spline (NURBS) models. Mainly, Rhino[®] is used by architects to facilitate drawing and modelling complex geometrical shapes that are difficult to model using other related tools. Grasshopper is a Rhino[®] plug-in that act as a Visual Programming (VP) systems to aid modellers in the process of writing scripts to develop parametric models. The VP system is defined as “any system that allows the user to specify a program in a two-(or more)-dimensional fashion” (Touloupaki & Theodosiou, 2016). The advantage of using Grasshopper, that is allowing modellers to model and perform analysis for architecture and

environmental analysis (daylighting and thermal analysis) by inputting parametric data and formulating parametric relationships instead of drawing and without any need of programming or scripting experience. The technical issue for a Grasshopper is a “definition”. The objects that make up a Grasshopper file fall into two main classes: Components and Parameters.

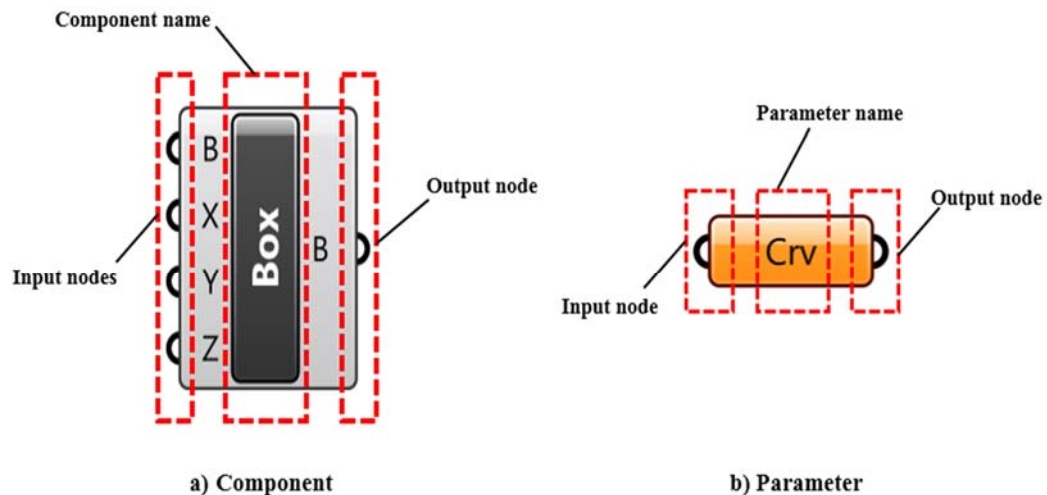

Figure 2-4: Components and parameters in Grasshopper

- **Components**

Figure 2-4 (a) shows the component definitions that are divided into three main parts as follows:

- The name located in the middle bar of component.
- The input grips of the component left side, which take input data to use in whatever operation the component handles.
- The output grips of the component right side, which contain whatever data is passed on after the component processes its input.

Output grips are sometimes connected to the input grips of other components, chaining them together into additional operations.

- **Parameter**

Figure 2-4 (b) shows the parameter definition that has just one input and output grid. Since the parameter only stores data, it never needs more than one of each.

Recently, new ways are being developed for integrating building modelling tools and building performance simulations tools during the conceptual design phase to provide a high level of interoperability. Distributed model method is one of the modelling methods which couple both modelling tools and performance simulation tools. It used to reduce the required time for modelling, where data is placed within a middleware component to distribute data between the modelling tool and performance simulation tools. The middleware is defined as “...not merely a simple converter between formats and platforms, but a system that is able to filter, modify and extend operator definitions to such a degree that the definitions reflect the needs of BPS environments” (Braasch, 2016).

For example, Rhino[®] is used to generate building geometry as a design tool. Grasshopper as middleware tool, can then translate the geometry back to building performance simulation (BPS) tool as EnergyPlus (Energy Simulation Engine) using a third party module, Grasshopper plug-ins. which allows modellers to perform a series of environmental performance evaluations by connecting Grasshopper with EnergyPlus as show in Figure 2-5. DIVA for Rhino[®]/Grasshopper plug-in, which allows modellers to perform a series of environmental performance evaluations by connecting Grasshopper with EnergyPlus. DIVA was initially developed at Harvard University by the Graduate School of Design and now it is developed and distributed by Solemma LCC (Solemma, 2015).

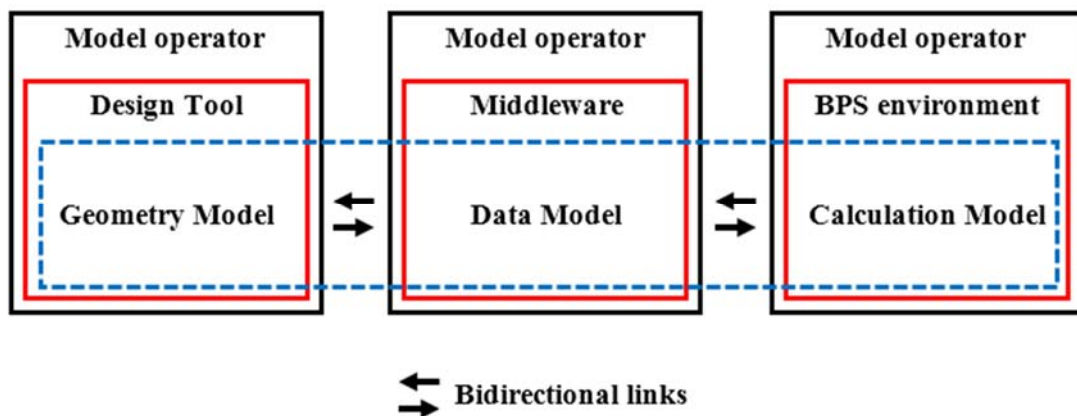

Figure 2-5: Distributed model method (Negendahl, 2015)

2.9.2 EnergyPlus, Performance Simulation Tool

EnergyPlus is a whole building performance simulation tool that couples the best features and capabilities from DOE-2 (the most widely recognized and respected building energy analysis program) along with new capabilities that comprises completely new code written in Fortran 90. EnergyPlus developed by the US Department of Energy as a simulation engine tool to create a well-organized, modular structure that facilitates adding features and links to other software's (Crawley, et al., 2000). EnergyPlus is an open source tool that can be connected with middleware (Grasshopper/DIVA) via the input and output format that are in text format. DIVA creates an Input Data File (IDF) and the simulations runs the EnergyPlus engine through a "RUN" batch-file. The results of simulation process are generated in various formats, mainly txt and CSV files. Figure 2-6 shows the structure of the EnergyPlus program, that has three basic modules as follows:

- **Simulation Manager Module**

Simulation manager controls and takes actions for simulation process initialization, simulation, gathering results with full interactions such as: sub-hour level, time step, simulation period, weather day-month-year.

- **Heat and Mass Balance Simulation Module**

EnergyPlus is a heat balance model that underlying based on thermal zone calculation method. Whereas, the building model is divided into thermal zones where the air in each thermal zone can be modelled as well stirred with uniform temperature throughout to accomplish the essential assumption of heat balance models (Crawley, et al., 2000).

- **Building Systems Simulation Modules**

After the completion of simulation for a time step, the building system simulation manager is called by heat balance module to perform and controls fully integrated simulation of loads and systems (HVAC, Electrical and Equipment systems).

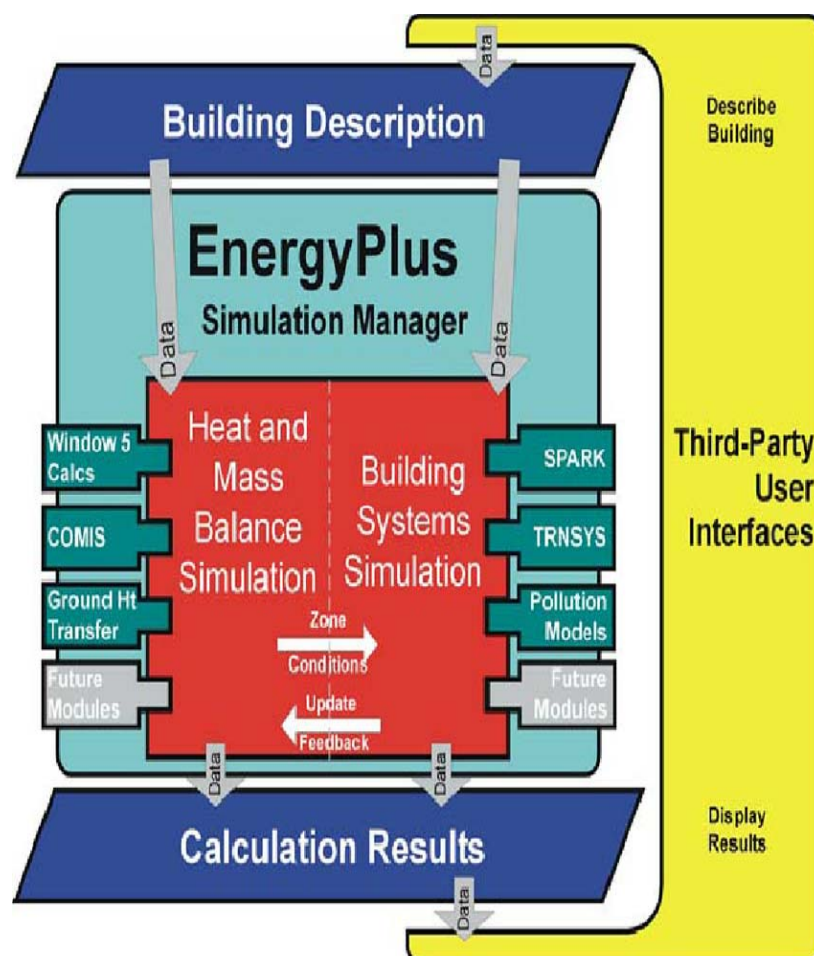

Figure 2-6: Overall EnergyPlus structure (Crawley, et al., 2000)

2.10 SUSTAINABLE BUILDINGS DESIGN OPTIMIZATION

Towards sustainable building design effectively in early design stages, it is important to perform energy performance assessment, although very complex and demanding process. Sustainable building design based on performance efficiency include a number of choices that satisfy specific criteria like economic, minimize energy consumption and environmental performance, which requires a great effort, time and special skills. To satisfy these criteria, how should the form of a building be varied, given that shallow plans promote the use of natural lighting but the increased wall surface area increases heat flows? How large should windows be, on each facade? Should the building include a small or large amount of thermal mass? For these reasons, it is normally conducted after the decision on major building elements, or in 3-4 alternative solutions. Consequentially, the assessment of these measures' impact on the occupants' thermal comfort and the building's energy performance. Recently, numerous methods and tools have been developed to address performance based design questions, mostly using optimization algorithms (Touloupaki & Theodosiou, 2016).

2.10.1 Optimization Model Components

Optimization models are an important in the decision making process to find the best solution from among the set of all feasible solutions. Any optimization model has three main components that presented in the following order: objective function, variables and constraints. Optimization models can be categorized into the terms of the objective function and the constraints nature. The main step of optimization problems is the process of identifying and expressing in mathematical terms of the objective, variables and constraints of the problem.

- Objective function: a quantitative measure of the performance of the problem that needs to be optimized.
- Variables: a collection of decision variables values for the solution of the optimization problem, which objective function reaches its optimal value.
- Constraints: a collection of constraints that restrict the values of the decision variables.

Evolutionary Algorithms (EAs) is defined as stochastic search methods that mimic the natural biological evolution and/or the social behaviour of species. Such algorithms have been developed to arrive at near-optimum solutions to large-scale optimization problems, for which traditional mathematical techniques may fail (Elbeltagi, et al., 2005). Many studies have developed computational systems based on evolutionary algorithms that seek fast and robust solutions to complex optimization problems.

2.10.2 Genetic Algorithms

Among the methods of optimization, Genetic Algorithms (GAs) use the evolutionary concept of natural selection to converge on an optimal solution over many generations. GAs are stochastic algorithm, which is based on the Darwinian principle of the ‘survival of the fittest’ for the selection and reproduction of candidate solutions, and how animal populations evolve in nature. GA is a technique used to automate the process of searching for an optimal solution, and it considered as a common optimization option utilized in sustainable building design due to energy systems complexity and GA capabilities (Ganjehkaviri, et al., 2017). GAs optimization start searching by randomly sampling within an optimization solution space, after that it uses stochastic operators to direct the optimization process based on objective function vales.

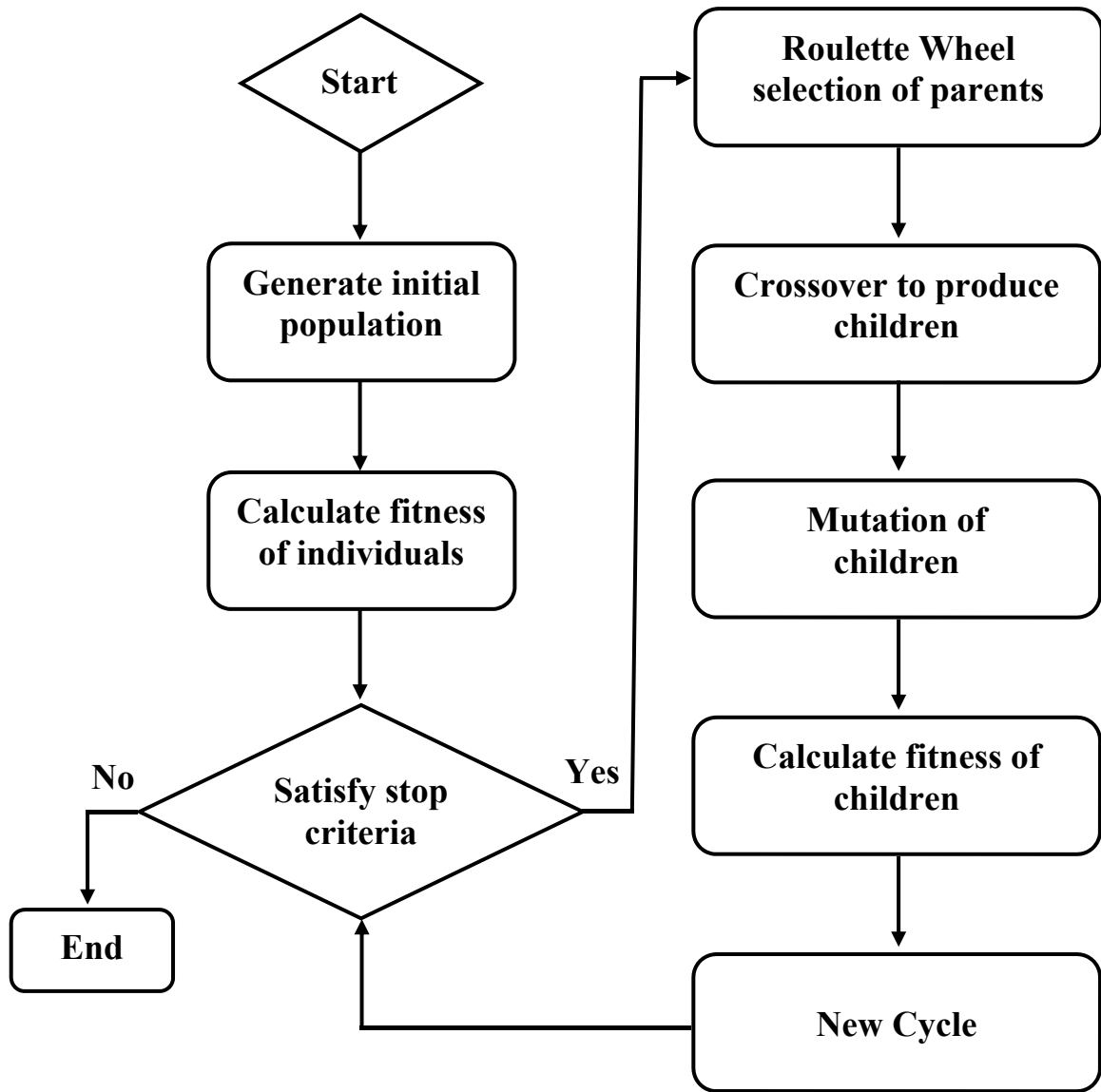

Figure 2-7: Genetic algorithms optimization problem flowchart

Under the terminology of GA, a solution to the optimization problem is an individual and the solutions group existent at each stage is a population. Each time a new population of individuals is created, it is called a generation. Each individual is represented by a binary string, reals, integers, characters or list of roles called a chromosome, which codes all the parameters of interest corresponding to that individual. The fitness of any particular individual corresponds to the value of the objective function at that point (Caldas & Norford, 2002). The basic three genetic operators which control the evolution

of the optimization problem solutions generations are reproduction, crossover and mutation. The probability of a given solution being chosen for reproduction is proportional to the fitness of that solution. Crossover implies that parts of two randomly chosen chromosomes will be swapped to create a new individual. Mutation involves randomly changing an allele in a solution to look for new points in the solution space. Figure 2-7 shows a flow chart for a genetic algorithm optimization problem.

GAs offer several attractive features as follows (Caldas & Norford, 2003):

- It can be applied for a wide range of optimization problems.
- It is publicly available, easily understood and implemented approach.
- It can be work and integrate with complex simulation tools.
- It can be reduced the time of optimization problem.

2.11 DATA VISUALIZATION METHODS

One challenge of the sustainable building design considering parametric analysis, however, is that it has a large number of input and output datasets. This numeric format is not easy for many decision makers to interact with, whereas decision makers are visual professionals and would prefer to make highly informed decisions quickly and to deal with intuitive visual formats rather than numerical datasets. Data visualization is a complex process, which is like an umbrella that covers both information and scientific visualization simultaneously. It encompasses various data quickly, effectively and efficiently. Nevertheless, traditional visualization methods for the energy analysis produce visual analysis results within the simulation tools as part of the modelling process or as a text report associated with model datasets.

The leading benefit of data visualization is that it not only provides graphical representation of data but also allows changing the form, omitting what is not

required, and browsing deeper to get further details. There is many data visualization techniques such as a Parallel Coordinate Plots (PCP) as shown in Figure 2-8, which is a graphic representation of data with every instance in a dataset represented by a polyline that are linked to maps and scatterplots that intersects several vertical axes, each axis representing a variable in the design space (Edsall, 2003).

The generative/parametric capabilities of Rhino/Grasshopper and its ability to record the results of each simulation into a readable format using Grasshopper components. Grasshopper record data plug-ins that can gather and record both input and output data through creating a text, excel or cvs files into a list format. This data is used to develop a graphical representation using parallel coordinate plots technique that allows the user to determine design options moving forward to get the final output value.

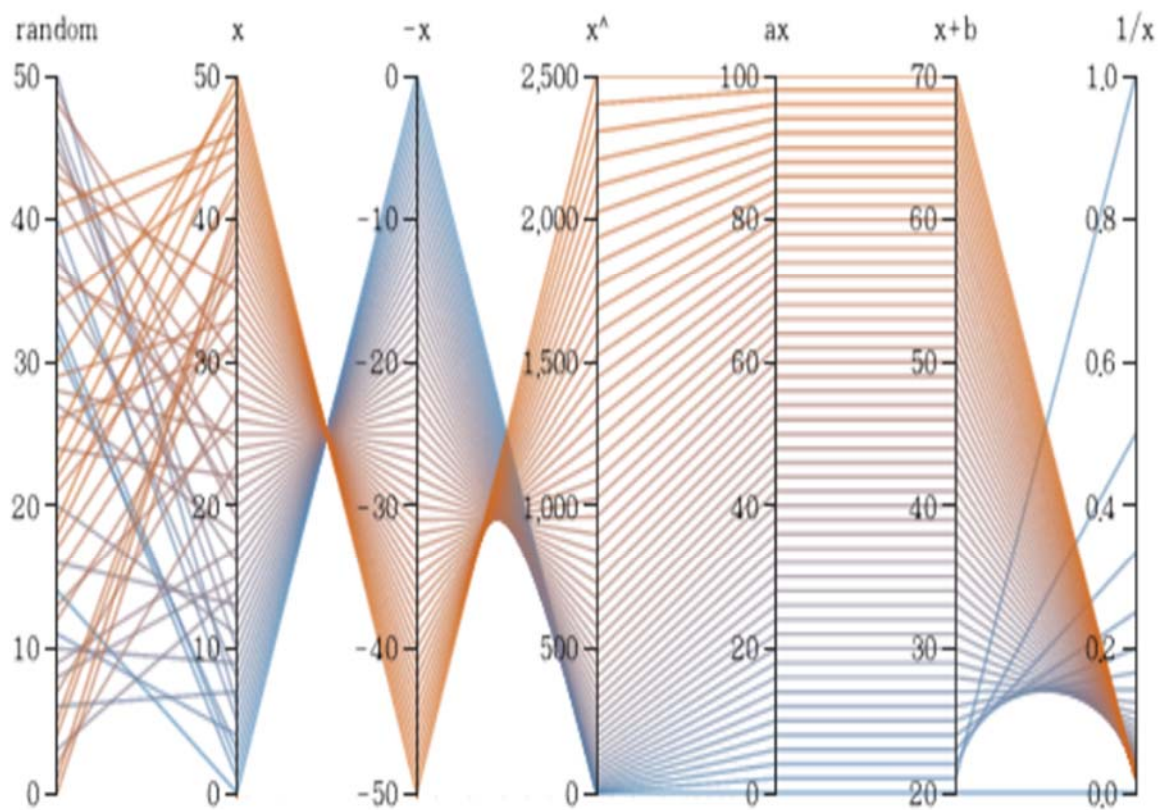

Figure 2-8: Parallel coordinate plot representative sample

2.12 APPROACHES USED IN SUSTAINABLE BUILDINGS DESIGNS

The literature review is presented in two sub-sections. The first one refers to residential energy modelling methods used to estimate energy consumption. The second subsection presents energy models created exclusively within the environment of Rhino Grasshopper. Then, a broad picture of former research on optimizing sustainable building design.

2.12.1 Residential Building Energy Modeling

Many techniques of energy modeling have been attempted to estimate energy consumption including artificial neural networks, statistical analysis of building consumption data, simulation and surveys. Artificial Neural Networks (ANNs) is the popular used method in forecasting buildings energy consumption. The main advantages of using ANN are its quality compared to other methods, resistance to faults and noise, and the compact nature of the models with quick answers (Melo, et al., 2013).

Chen, et al. (2017) established a baseline building model that both coupling local construction practice and green standard in Hong Kong including weather analysis data, different internal loads assumptions, methods of ventilation control and running periods. All output results generated based on a specific input parameters using a dynamic simulation program.

Eltaweel & Su (2017) proposed a control method into office buildings using Rhino/Grasshopper plugins for automated venetian blinds to optimize the daylight effectiveness, protect occupants and maximize daylight penetration. A case study was conducted for an office building in New Cairo, Egypt.

Elharidi, et al. (2017) provided insights for existing building performance in Egypt, also presented a development to facilitate modelling of the Egyptian office buildings in future policy that accommodate energy consumption, environmental conditions and internal thermal comfort.

Samuelson, et al. (2016) developed a framework allows designers during early design stage using parametric energy simulation for the whole residential building simulation. The energy design parameters used are windows to wall ratio, six types of Glass, building orientation wall insulation and building shape.

Biswas, et al. (2016) presented a model to predict house and heat pump energy consumption using ANN for TxAIRE Research and demonstration houses, which are designed to serve in the facilities testing for a new technology. The input variables are the outdoor temperature, number of days and solar radiation. The selected data used for the learning ANN represented the recorded energy consumption of TxAIRE for selected number of days during summer.

Aibinu, et al. (2015) developed, tested and validated ANN models for predicting the costs of electrical services components during building design stage. The data mining of over 200 building projects examined in the office of a medium size electrical contractor, 71 usable data (28 residential buildings and 43 educational buildings) were used for ANN modelling. The validated model was converted to user interface desktop application called “Intelligent Estimator”.

Negendahl (2015) explored the building performance simulations (BPSs) utilized in early design stages concerning model level operation and model level collaboration. This study concluded the effectiveness for coupling dynamic models with design tool, visual programming languages and BPS to provide better support for the designer during the early design stages of design opposed to the current implementation of gbXML or IFC or unaccompanied use of simulation packages.

Farzanaa, et al. (2014) predicted the demand of future energy for urban residential buildings using different predicted demand models: ANN model, two Grey models, a Regression model and Polynomial regression models. The energy consumption data used in simulation model were collected using a questionnaire survey. The results showed that ANN model and Grey Model were more acceptable than the other models according to the “Prediction precision”.

Turhan, et al. (2014) developed a model for existing buildings used ANN to predict internal heating electricity loads benefiting from energy efficiency measures such as: length to width ratio, coefficient of wall heat transfer, volume to area ratio, building external surface area, all windows area to total external surface area ratio.

Attia, et al. (2012) presented an energy oriented tool software for both energy simulation and building modelling coupling the Egyptian context and to facilitate decision making for sustainable design buildings. A residential benchmark was established as a mean of developing a decision support tool using EnergyPlus simulation tool and sensitivity analysis.

Zhao & Magoulès (2012) introduced a new selection method of subsets for features influence the model performance using support vector regression to predict energy usage for office buildings. EnergyPlus was used to generate three datasets for both training and testing.

Jakubiec & Reinhart (2011) presented a workflow linking DIVA with DAYSIM and EnergyPlus for energy and daylighting simulations as an example for integrating the thermal comfort and daylight performance. The methodology was created to inform designers about daylight behaviour and energy consumption of buildings in connection by making use of the lighting schedule from the daylight simulations and using it for the energy calculations.

Zhao (2011) developed a mathematical model using EnergyPlus to generate energy consumption profiles datasets for single or multiple buildings. Support vector machine models are trained and tested on the energy prediction based on datasets with high prediction accuracy. An interface application was developed to facilitate and control EnergyPlus simulation process.

Wong, et al. (2010) predicted the daily electricity consumption of heating, cooling and electric lighting for office buildings using ANN model in subtropical climates based on day-lighting controls. Statistical analysis energy models need collecting historical performance data to correlate the consumption of energy with the influencing variables.

Ekici & Aksoy (2009) predicated building energy usage benefiting from orientation, thickness of insulation and the ratio of transparency using backpropagation neural network model. Three different building samples were used to generate dataset for ANN modelling with different form factor,

insulation thickness 0-2.5-5-10-15 cm, orientation angle varied from 0°-80° and the ratio of transparency were chosen as 15-20-25%. MATLAB ANN toolbox was used for developing the prediction model.

Neto & Fiorelli (2008) compared both the EnergyPlus and an ANN model for predicting the energy consumption in an administrative building. A feed-forward neural network was trained and tested with three layers: one input layer with 5 neurons (outdoor temperature, humidity, day-type and two solar radiation parameters), one hidden layer with 21 neurons and one output layer with one neuron represented the total daily energy consumption. Also, another simple ANN model was developed with two input parameters (internal and external temperature). The results of both models were appeared to be very closed.

2.12.2 Literature Review within Optimization

Research interests in optimization building design considering building performance have increased with the aim to reduce the energy consumption. During early design stage there is an opportunity to reduce energy consumption without increasing the project cost or prejudicing occupants' thermal comfort.

Yang, et al. (2017) developed an optimal model to optimize building envelope design considering building energy performance. The developed model is used to minimize construction cost related to building envelope, minimize the envelope energy performance and maximize the windows opening rates. The model integrates a multi-objective Genetic Algorithms optimizer (NSGA- II). The population size and number of generations, were determined thorough a sensitivity analysis. A real office building case study was established to identify the potential strengths and weaknesses of the proposed model.

Santos, et al. (2017) proposed an approach coupling 3D representations of building with a single parametric model to optimize multiple building envelope parameters considering energy efficiency. The model allowed to automatically generate the geometry of an energy model from a complex 3D CAD model (Curved and double curved geometries).

Touloupaki & Theodosiou (2016) proposed a workflow coupling both genetic algorithms and energy simulation through Rhinoceros/Grasshopper and plugins Ladybug and Honeybee as one platform to minimize the building lifecycle energy requirements and achieve green building standards.

González & Fiorito (2015) integrated the DIVA plugin and the Genetic Algorithms embedded in the evolutionary solver Galapagos for Rhinoceros/Grasshopper to calculate energy consumption, daylight metric and CO₂ emissions to reach the optimum or near optimum solution by controlling different shading configuration. The results showed that the optimization process reduced both energy consumption and CO₂ emissions with an annual energy savings of about 35%.

Lin, et al. (2013) developed an optimization model using Genetic Algorithms in connection with the characteristics of both modelling process of parameterization and energy saving design during schematic design stage. The energy usage was calculated by developing a simplified model to calculate the overall energy consumption of air conditioning, cooling, heating and equipment's by means of steady calculations as well as simulation. The model is based on software platform developed by a computer language and OpenGL

interface and human-computer-interaction which achieved automatic modelling for parameterization of building energy saving.

Tuhus-Dubrow & Krarti (2010) optimized two shape and nine construction parameters to minimize energy usage for a residential building. The developed model coupled Genetic Algorithm to a whole building simulation engine (DOE-2). The results indicated that the rectangle and the trapezoidal were consistently the optimal shapes.

Wang, et al. (2006) presented a methodology to optimize building shape using Genetic Algorithms considering both life cycle cost and life cycle environmental impact as an objective functions used to evaluate the green building design performance. The developed model employed the building shape related variables and other envelope related variables such as windows ratios and overhangs.

Wang, et al. (2005) presented a multi-objective optimization model that could assist designers in green building design. Variables in the model include those parameters that are usually determined at conceptual design phase such: building orientation, aspect ratio, window type, window to wall ratio, wall type and roof type that have critical influence on building performance. Life cycle analysis methodology was employed to evaluate design alternatives for both economical and environmental issues.

Coley & Schukat (2002) minimized energy consumption by integrating Genetic Algorithms with human judgments: 'architectural appeal' was assessed post- optimization through the presentation of both optimal and near-

optimal designs in a visual manner, enabling the user to choose based on preferences that need not be formalized as constraints or objectives.

2.13 RESEARCH PURPOSE AND LIMITATIONS

The great efforts discussed in sustainable building design studies can be categorized based on the research purpose, parameters studied and limitations. Most researches concerned with sustainable buildings conducted on sustainable building design optimization or analysis, parametric energy analysis, interoperability between energy simulation and design tools, analyse sustainable building performance with respect to their design and the assessment of both building life cycle performance and building life cycle cost in the early design stages.

- **Parameters studied**

Various parameters were studied with focus on building envelope construction, building form and building skin façade. These parameters include wall insulation types, wall thickness, wall insulation thickness, building orientation, building dimensions, building shape, window to wall ratio, windows areas and the characteristics of glass. On the other hand, the parameters of simulation process like weather data analysis and location.

- **Limitations**

Although the previously mentioned studies related to energy simulation, parametric analysis and optimization studies are significant to explore effective ways towards the improvement of sustainable building design, several limitations and technical barriers faced in building energy analysis that must be addressed to successfully automate and generic the process of sustainable building design. Among the limitations are:

- The preparation of model for simulation process is a time consuming process, typically with limited or no Graphical User Interface tools;
- The difficulty to obtain accurate and consistent data related to environmental impact for all building component and materials;
- The lack of interoperability between design and energy analysis tools, that is may be performed in manual or semi-manual process, resulting in errors and misunderstandings;
- The inconsistency of multidisciplinary analysis for daylighting and energy simulations which are typically performed with two different tools, which requires specialized skills;
- The mismatch between optimization method and design practice in terms of variables; and
- The variety of building optimization problems in terms of the following items:
 - the number of variables;
 - the type of variables;
 - the number of constraints;
 - the optimization model types (single or multi objective);
 - the building energy simulation tools used for evaluation; and
 - the optimization algorithms.

2.14 SUMMARY AND CONCLUSIONS

This chapter introduced the concept of sustainability in construction industry, which is a very important issue. It was reported that more than 50% of the CO₂ emissions in the world came from the energy consumed by buildings related activities which leads to a climate crisis. Therefore, there is a global trend towards sustainable building design and construction to protect the surrounding environment. The goal of green building is to achieve the following issues:

- Environmental issues: improve air and water quality, reduce waste streams and restore natural resources.
- Economic issues: reduce operating costs, improve productivity and optimize buildings life cycle cost performance.
- Social issues: improve indoor air quality, enhance building end user health and comfort and improve overall quality of work life.

A brief discussion of the international sustainable building rating system was introduced in this chapter, which reflects the interest of the institutions and government agencies interested in preserving the environment. The Egyptian energy efficiency code for both residential and commercial buildings was developed by the Egyptian Housing Building National Research Centre to be the basic milestone for sustainable building design in Egypt. Further, the Egyptian green pyramids rating system was developed to accommodate, control, evaluate and assessment of sustainable building in context of Egyptian environment. Also, a brief discussion for the approaches towards sustainability to meet a number of performance requirements relating to indoor environmental quality, material efficiency and energy efficiency. The benefits of sustainable building design were illustrated as the overall idea to avoid the depletion of energy, water and raw materials. This chapter introduced a summary of the sustainable building design principles that were implemented in previous studies through: the empirical rules, the simulation based trial-and-error method, the knowledge-based method and the optimization method.

Also, the energy consumption methods including engineering, statistical and artificial intelligence methods were reviewed. This chapter has clearly show that parametric energy analysis is a powerful way in generating large parametric data sets via building performance simulation. To utilize and

navigate such data sets, Rhinoceros/Grasshopper introduced to be used as one platform to overcome the previous limitations regarding the lack of interoperability. As this research is concerned with the optimization of building design considering energy performance, the advantages of using Genetic Algorithms as an optimization tool are discussed. Finally, different approaches used for modelling, simulating, predicting and optimization of sustainable building and environmental issues are reviewed. This research intends to build on literature findings and attempt to avoid its limitations and technical barriers. It aims to develop a full-automated model for sustainable building design optimization in Egypt.

Chapter 3 ENERGY PERFORMANCE MODELLING

3.1 INTRODUCTION

This chapter introduces for the calculation methods, simulation engine and legislation behind the residential buildings energy performance. Firstly, the role of energy modelling during conceptual design phase, the energy demand and its affecting factors are presented. Then, it gives a brief description about the parametric design theory and its role in energy performance. The contents, calculation methods and simulation engine of energy performance are demonstrated.

3.2 ENERGY MODELLING DURING CONCEPTUAL DESIGN

In order to achieve the highest possible energy savings, energy modelling should be initiated through the early (conceptual) design phases. During this phase decisions regarding building's form, windows to wall ratio for each facade, orientation and construction materials assemblies are usually made as these decisions have a reflective impact on how the building will perform. Often, the architects develop several design options to present to the client. Perhaps one option has an elongated shape, another may be L-shaped a third may be rectangular with an interior courtyard. The options give the client the opportunity to provide feedback on the proposed design and interior space planning. Of course, if an energy use assessment of each option can be provided at this stage, then that will be another very important factor for the team to consider. Once the geometry is created, the energy model can be populated with information on the loads.

At the conceptual design phase, exact information is not yet likely to be determined, so engineering judgment is important to provide a realistic assessment. Suppose that the design team is working on a new office building,

massing model may be developed, however it is unlikely that specific office locations have been determined. So at this stage, it would be reasonable for the energy model to be divided into simple zones (for each exterior exposure) and interior zones.

Many energy simulation software tools have this information (energy simulation settings) stored in a library (or allow creation of custom libraries) to allow users to quickly apply it to the energy model. Once this information is applied to the model, the design team can perform iterative simulations to determine the best performing massing scheme, the optimal orientation, the impact of different construction materials, and the impact of different window-to-wall ratios. Since some assumptions must be made at this stage, the energy simulations may not predict energy consumption exactly. However, if our assumptions are sound, we can get a good sense of the impacts of design decisions at an appropriate order of magnitude. Moving forward, we can be confident that the right concepts are in place and can then assess them in greater detail as the design progresses.

3.3 ENERGY DEMAND

The buildings, which are considering energy performance includes many factors such as, cooling, heating, artificial lighting and plug-ins electricity usage. The energy consumption of a building is influenced by many different factors. They could be divided into four groups: Building Envelope, Indoor Climate and the function of building, Surrounding Climate and Heating and Ventilation System and Lighting (Figure 3-1).

All the four groups influence the energy demand of a building. Each group has an effect on the others. For example, a building with heating system only cannot guarantee that the indoor climate will be within the allowed range in

hot summer periods, unless there is a cooling facility available (Lugmaier, 2000).

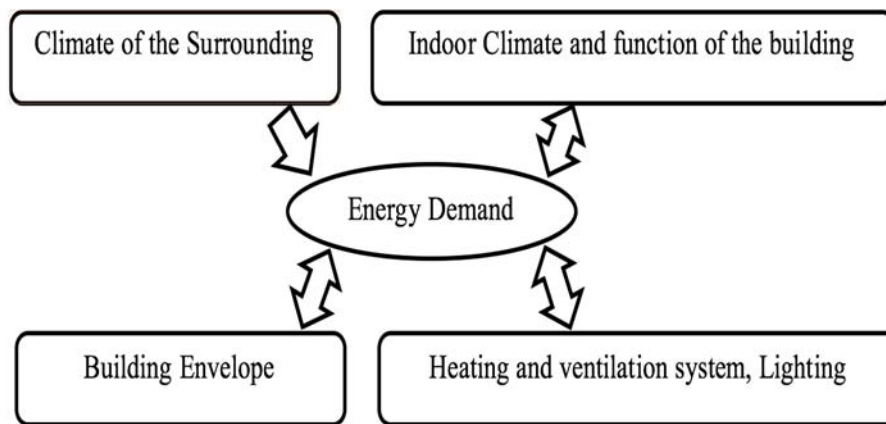

Figure 3-1: Energy demand

3.3.1 Climate of the Surrounding

The outdoor climate can be described by a set of parameters, such as: the temperature surroundings, speed of the wind, pressure, moisture and outdoor air cleanliness; solar radiation, rains and the radiant temperature. The main weather data needed for buildings design in hot climates contains the following criteria as presented in Table 3-1.

Table 3-1: Climatic data

Data required	Units	Relevance
Monthly mean max temperature	°c	Thermal comfort analysis
Monthly mean min temperature	°c	
Monthly mean max humidity	%	
Monthly mean humidity	%	
Monthly mean rainfall	mm	Vegetation
Sunlight	hours	Natural lighting
Absolute max temperature	°c	Thermal expansion and effect on building material
Absolute min temperature	°c	

The most important factor of the surrounding climate is obviously the temperature of the outdoor air. It is observed that there is a kind of sinusoidal relationship between the air-dry bulb temperature and the sun time. For example, in the month of June in a certain locality where the sunrises at about 5 a.m. and the sunset at about 7 p.m., the time of minimum temperature falls at about 4 a.m. and that of maximum temperature at about 4 p.m., i.e., with a lapse of about 12 hours. Therefore, it is important to develop necessarily accurate values for the energy demand of buildings and it will often be important to consider outdoor climate changes. Reference to the room temperature and the solar radiation are the most important parts to consider (Lugmaier, 2000).

3.3.2 Indoor Climate and Function of the Building

The most significant issues for the building indoor environmental are the moisture content, internal zones temperature, sources of internal heat loads, the supply of fresh air, both artificial and natural lighting, occupation time schedule and the working periods of the installations in the building. For getting, an acceptable degree of the surrounding and internal climates has to be analysed dynamically over one whole year as a minimum.

3.3.3 Building Envelope

The energy balance has a significant influence on performance of the building design. The different capabilities of the building envelope to store heat in the walls, roof or floor has an important influence on the cooling and heating energy demand. Even for buildings, which are only heated, not only the heat transmission factors for the different outdoor parts like outer walls, windows, roof and floor construction factors are enough to consider, also the heat storage capacity of the different parts have to be taken into account. Because these factors also influence the cooling of the building during the night, or the

possibility of storing and using, for example, solar heat gain and losses during the night. The effects on the indoor climate in the summer will also be highly influenced by the storage capacity of the building. It is often possible to avoid an air conditioning system, simply by changing the construction materials of the building. The shape and orientation of the house are also influencing factors on the energy consumption. The ratio between the volume and the outdoor surface, especially, determines the energy demand of building. For large buildings this relation can be overlapped by the bigger lighting and cooling energy demand for interior rooms; windows and solar shading have an additional impact.

3.3.4 Heating and Ventilation System, Lighting, Appliances

The issues that affects the energy consumption design are the Air Conditioning (AC) type (heating or cooling AC systems), the system type (the AC system with water only or with air and water), lighting system, home appliances, energy transfer and heat recovery system within the building.

These four groups affect the balance of household energy and the difficulty to demarcate from each other. Consequently, it can be noted that it is important to investigate these parameters at early phases of buildings design process.

3.4 BUILDINGS ENERGY ASSESSMENT

The energy performance of a building consists of various factors, such as heating, cooling, lighting and electricity consumptions. The energy performance of a building is usually defined as a comparable, standardized use based energy consumption. Standardized use means that the factors that affect energy consumption, including internal heat gains and ventilation rates, are standardized. Standardized energy consumption can be calculated by a floor area or cubic content, for example, and the consumption can be

normalized to corresponding average weather conditions (Pietarila, 2013). The building thermal performance refers to the modelling process where the energy transfers between a building and the external environment. Many processes of heat exchange are possible through the building and its surroundings (Figure 3-2).

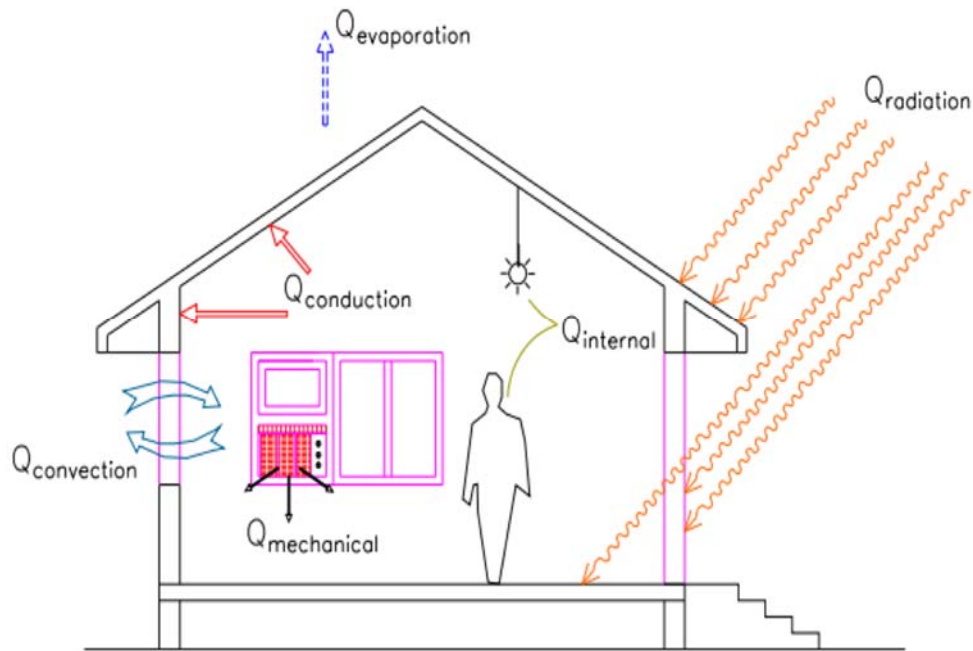

Figure 3-2: Heat exchange through a building and its surroundings (Berisha & Dragusha, 2015)

Heat flows by thermal conductivity through different building elements such as floor, walls, ceiling, roof, etc. In addition, heat is transferred from various surfaces by radiation and convection. Further, solar radiation is transmitted through translucent windows and the internal surfaces of the buildings absorb these radiations. There may be evaporation of water resulting in a cooling effect. Heat is also added to the space due to the presence of human occupants and the use of lights and equipment. The thermal performance of a building depends on a large number of factors. Figure 3-3 presents the various factors that are affecting the building heat balance as follow (MNRE, 2015):

1. Design parameters (building dimensions, shading devices, orientation, etc.)
2. Materials physical properties (specific heat, density, transmissivity, thermal conductivity, etc.).
3. Weather data (humidity, speed of wind, solar radiation, ambient temperature, humidity, etc.).
4. Function of building and its usage data (air exchange, internal gains by occupants, lighting and equipment, etc.).

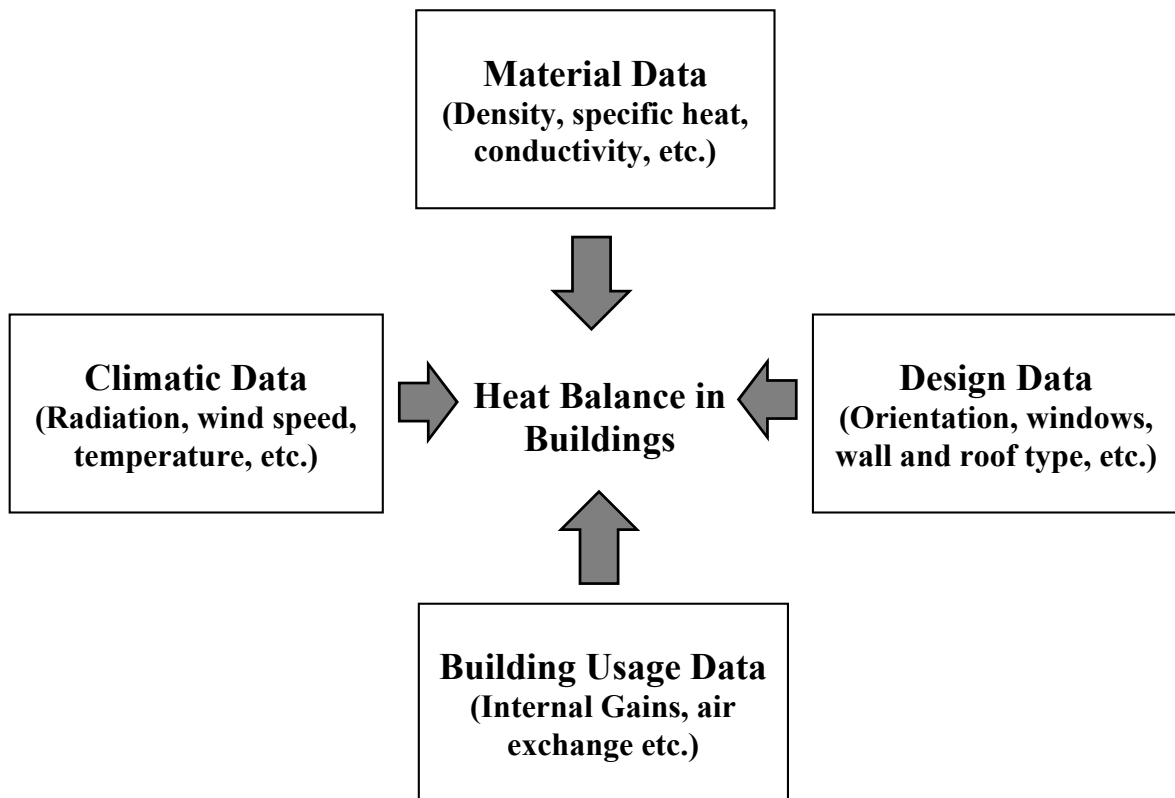

Figure 3-3: Thermal simulation flow paths of a building

There are several techniques, which are used to estimate the building performance. These techniques may be classified under Correlation, Dynamic and Steady States methods. Several techniques provide information simply for the average temperature or internal loads on a monthly or annual basis. On other side, there are complex techniques that require more detailed input data.

However, the latter achieve a more accurate analysis and provide results on an hourly or daily basis. For this study, the methods which are simple, amenable to hand calculations and easy to understand are presented. The methods of energy performance calculations can be divided into two main groups (Pietarila, 2013) :

1. ISO DIS 13790 and NBCF D5 (monthly-based method).
2. Dynamic simulation methods (calculation step typically one hour).

The monthly based methods are easy to use and their initial data is lighter and clearer than in simulation methods. Their disadvantage is that internal temperatures cannot be calculated as with simulation methods. Moreover, cooling energy demand is easily calculated with the simulation methods. However, using the simulation methods requires experience and determining the initial values of the calculation is often laborious. Calculating energy performance can be divided into two main parts:

1. Calculating the net demands of heating and cooling.
2. Calculating the energy consumption of technical systems.

3.4.1 Buildings Energy Assessment through Standards

A series of standards aimed at defining a common calculation methodology, harmonized throughout different European countries, is currently under development by CEN (European Committee for Standardization). Those standards can be grouped into three categories (Corrado, et al., 2007):

- The first category deals with standards that define the different types of energy ratings of a building (design, asset, tailored, operational) and

sets general criteria and validation procedures for the calculation models.

- The second category includes standards that concentrate on the assessment of the thermal performance of the building and provides input data, material properties, boundary conditions and calculation procedures of the net energy needs for space heating and cooling.
- The third category includes standards that provide the calculation procedures for system losses and efficiencies for the different energy systems (space heating/cooling, lighting, ventilation and air conditioning, use of renewable) and allow the annual energy use to be determined in terms of delivered energy-ware and primary energy from the energy needs for heating, cooling, and lighting.

The most important standard in the second category is ISO/FDIS 13790 (ISO, 2007), which provides three building net energy calculation methods for space heating and cooling, common boundary conditions and input data. The first method is a quasi-steady state method based on a monthly balance of heat losses and heat gains. The second method is an hourly calculation method based on a simplified analogous electric circuit. As a third choice, it is possible to use any detailed building energy simulation method. The ISO/FDIS 13790 is developed by Van Dijk and Spiekman (2003), based on a monthly balance of heat gains and heat losses determined in steady state conditions. Quasi-steady state energy performance method gives the possibility of quick energy performance assessment feedback. Dynamic effects are taken into account through the introduction of an internal temperature adjustment for heating and cooling intermittency and of a utilization factor for gain-loss mismatch. The basic formulations of the model (Corrado, et al., 2007) are:

- The monthly energy need for heating Q_{NH}

$$Q_{NH} = Q_{L,H} - \eta_{G,H} \cdot Q_{G,H} \quad \text{Equation 3-1}$$

- The monthly energy need for cooling Q_{NC}

$$Q_{NC} = Q_{G,C} - \eta_{L,C} \cdot Q_{L,C} \quad \text{Equation 3-2}$$

Where:

$Q_{L,H}$ is the heat losses for the heating mode;

$Q_{L,C}$ is the heat losses for the cooling mode;

$Q_{G,H}$ is the heat gains for the heating mode;

$Q_{G,C}$ is the heat gains for the cooling mode;

$\eta_{G,H}$ is the gain utilization factor for the heating mode;

$\eta_{L,C}$ is the loss utilization factor for the cooling mode.

The utilization factors represent the portion of gains (during the heating season) or of losses (during the cooling season) that contribute to the reduction in the heating demand (during the heating season) or in the cooling demand (during the cooling season). The non-utilized part of the gains (in winter) or of the losses (in summer) depends on the dynamic mismatch between the gains and losses, which may cause an overheating over the heating set point temperature in winter or an under-cooling below the cooling set point (e.g. during summer nights) (Corrado, et al., 2007).

3.5 THERMAL PROPERTIES

The overall thermal balance of a building is generally given by the difference between heat gains and heat losses. Heat gains are defined by the sum of internal heat generation (through people and appliances) and solar radiation

through transparent envelope parts. Where, heat losses are defined by the total transfer heat through the building envelope from inside to the outside.

- **Heat loss by transmission**

Heat is transferred through the building envelope if there is a temperature difference between the exterior and the interior space. The underlying physical principle of this phenomenon is thermal conduction. Building envelop, thermal insulation is significant to reduce losses of cooling or heating to the building outdoor, subject to the surrounding weather conditions. If both the outdoor and indoor temperatures are very close, thermal insulation is less important. In warm climates, the temperature difference is typically less, 0 – 10° C as shown in Figure 3-4.

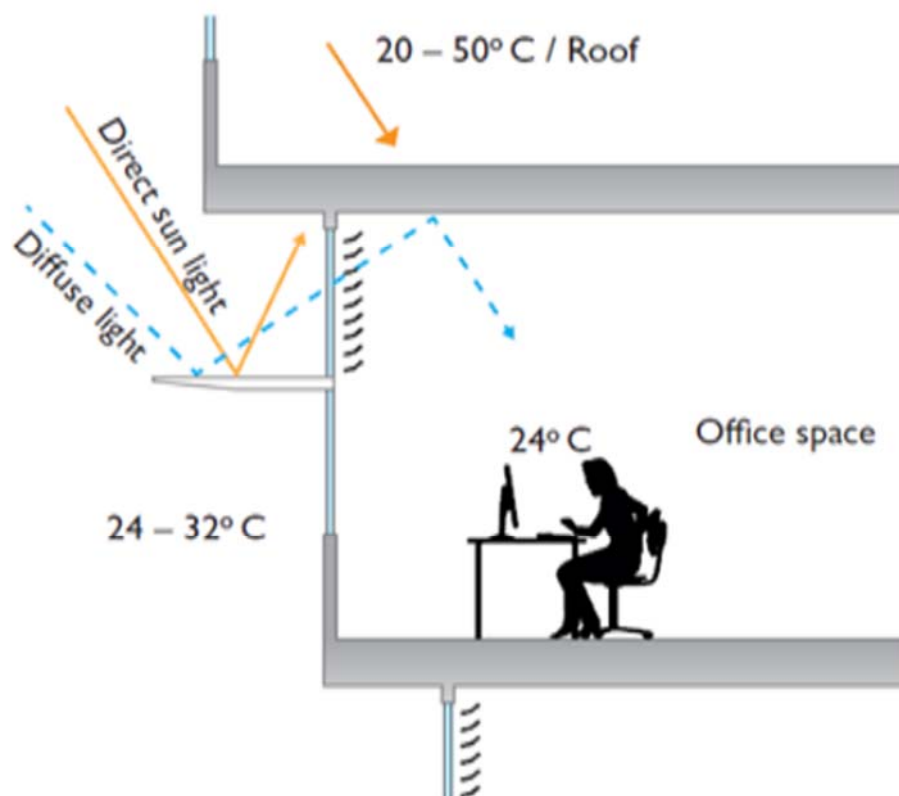

Figure 3-4: Section through a daylight building in the tropics (Berisha & Dragusha, 2015)

During night-time, the difference in temperature may be small, while at daylight it could be 10 - 15° C. However, during daytime, solar radiation will heat up the roof, consequently the difference in temperature may be up to 20 - 30° C. Therefore, roof thermal insulation is very important than to insulate the building walls in hot climates. The rate of heat exchange is dependent on the thermal conductivity, the property of a material to conduct heat. In the construction industry, it is of common practice to use R-values (resistance) and U-values (conductivity) to account for heat transmission. Besides the thermal conductivity of a material, these values are also dependent on the thickness of the product. The amount of heat transmitted through the building envelop is a decisive factor for the total energy needs of a building. In the humid and hot climates, it is recommended that thermal insulation values for building envelope walls and roof should have an even lower U-value. In the aim of creating more energy efficient façade constructions, national and international building regulations prescribe nowadays a maximum allowable U-value for the external closures of heated spaces 0.28 W/m²K (Watts per square meter per degree Kelvin) for wall constructions and 2.2 W/m²K for doors and windows (Heidegger, 2013).

- **Heat gain by solar radiation**

Solar radiation enters a building in the form of light. It has important effects on both the heat loss and heat gain of a building. When light hits an item it can be transmitted, reflected or absorbed. In most cases a combination of these three actions occurs as shown in Figure 3-5. According to the energy conservation law, the following statement for the incident flux can be established (Heidegger, 2013):

$$\alpha + \tau + \rho = 1$$

Equation 3-3

The ratio between reflection, transmission and absorption is material dependent. Since glass is a material with high light transmittance (τ), the main part of solar radiation enters the building through the transparent parts of the building envelope. Once inside, the sunrays will hit the interior surfaces and will be again transmitted, reflected or absorbed. Reflection (ρ) is the process in which a fraction of light, incident on a surface is returned into the same hemisphere containing the incident radiation. Absorption (α) in turn is the process by which incident radiant flux is converted to another form of energy, commonly heat.

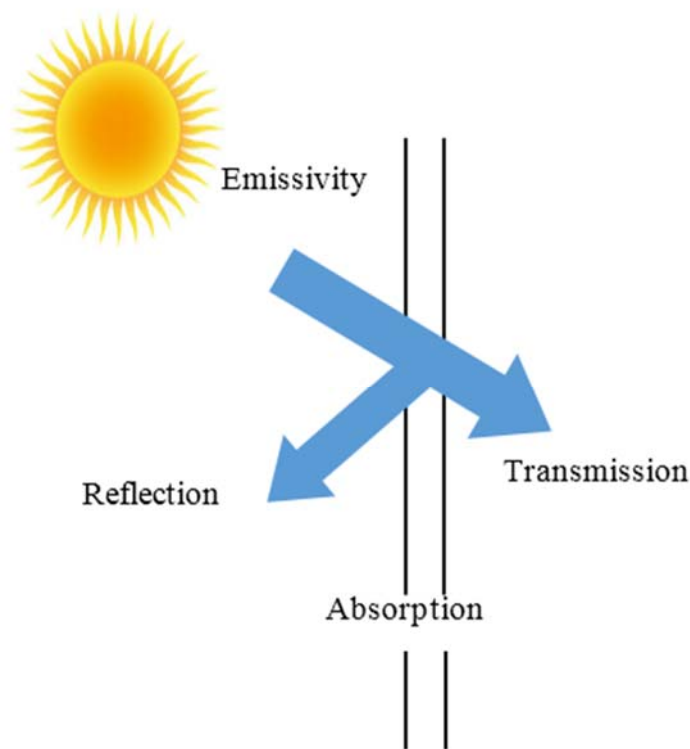

Figure 3-5: The radiant energy transfer

- **Heat loss by air infiltration**

Building envelope constructions are never completely airtight. Through small cracks and joints, warm indoor air flows towards the colder outside space. Following the general rules of fluid dynamics, this dissipated volume of warm

air is replaced by colder outside air. The difference in heat content between the cold and the warm air defines the heat loss by air infiltration (Figure 3-6). In this context, the amount and nature of joints is a decisive parameter.

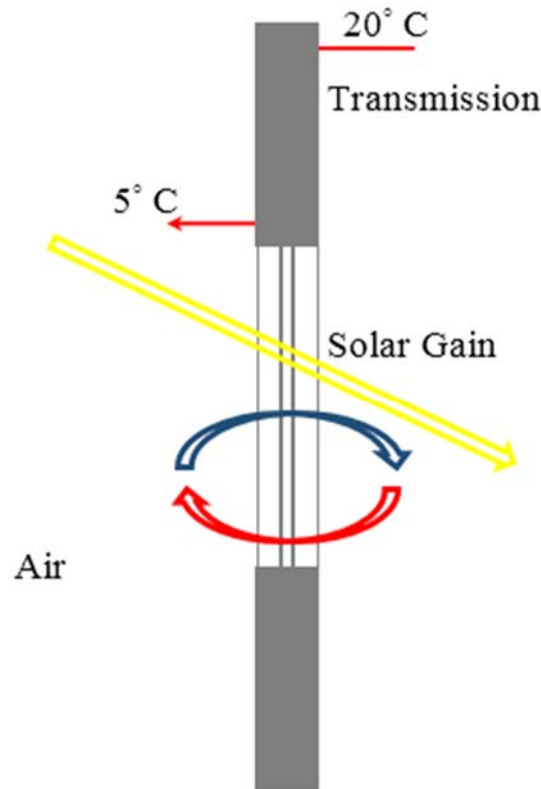

Figure 3-6: Energy flow through a window (Heidegger, 2013)

- **Glass Thermal Properties**

When examining thermal properties of an envelope construction, it becomes clear that the amount of glazed area and glazing selection represents a critical factor in the determination of its energy performance. The area of glazing may be limited whereas still providing comfort, adequate daylight and view. This conclusion can be drawn from the analysis of the specific material properties of glass. Given its high U-value and the relatively high amount of joints needed in the construction of windows, the glazed areas represent the weakest link when it comes to heat losses. Buildings with over glazed systems in hot

climates are costly, only not related to energy usage because the high demand of cooling loads but also due to the need of bigger and more expensive cooling system. On the other hand, windows are mainly responsible for solar radiation and the resulting internal heat gains.

Determining the glazing properties are very significant issue to control the daylight amount, light quality and solar heat gain amount passes through the building, along with other factors. They are also very important to control both thermal and visual comfort of building occupants. The most significant proprieties of the construction, coatings and materials that structure translucent panels, skylights and glass windows or any other items that are used to allow solar radiation passes through a building.

Glass thermal conductance (U-value)

For the components of building envelope, reasonable heat flow passes through windows due to temperature difference is a function of the U-value, which is measured the thermal conductivity. U-value is the rate of transferred heating for unit area, for unit temperature difference between both colder and hotter sides. It is important to know which units could be used by designers so U-value have $W/(m^2K)$ in SI units (watts per square metre kelvin) and $BTU/(h^{\circ} F. ft^2)$ in Imperial units. (British thermal unit per square foot per hour per Fahrenheit degree). U-factors could be expressed by R-values, which are equal $1/U$ -factor. They are measured for both the glazing only (glass centre) or for the whole window assembly with frame and spacers. Whereas, heat flow rates have an important difference between the glass edges, glass centre and frame portions of unit, therefore the glass U-value is the value most-often reference to the whole window assembly. The trusted source for this

information is the National Fenestration Rating Council (NFRC) (Autodesk, 2015).

In hot climates Solar Heat Gain Coefficient is often very important than the glass U-values because the heat which gains from direct sunlight radiation are more important than conduction through the window. Otherwise, in cold climates the use of lower U-values are typically the most significant property of the window and a rule of thumb is to look for windows with a U-value of 0.35 or less (Imperial units) (Autodesk, 2015).

Solar Heat Gain Coefficient

Solar Heat Gain Coefficient (SHGC) represents the amount of heating incoming from sunlight that is transmitted into the building, against the amount that is reflected away. The sun light contains infrared and other non-visible light with long-wave radiation that causes heating. Generally, this thermal property could be dependent on the entire glazing unit performance, not just the glass. The SHGC is influenced by glass type, the number of glass layers, coating, tinting and shading device for the window or skylight frame.

The SHGC is a dimensionless number that falls between zero and one, where zero expressing that none of the sun's heat pass into the building (total resistance), otherwise one expressing that all incoming heat from sunlight comes into the building (no resistance). Typically, the values of SHGC for physical products range from 0.2 to 0.9. Selecting the most proper SHGC is influenced by openings size and placement as well as surrounding weather conditions and other design parameters (Autodesk, 2015). SHGC is considered important parameter especially in warm and sunny climates whereas; cooling is the dominant thermal issue.

Autodesk (2015) recommended using the lower SHGC values for glazing below ~ 0.4 . On the other side, to reduce building heating loads in cold climates and to enable passive solar heating, SHGC should generally have higher values. For normal un-tinted and uncoated glass, SHGC can be about 0.9, whereas values can be as low as 0.25 or even 0.15 for some specialized glazing units. The SGHC depends on visible light transmission for spectrally selective glazing. The Light to Solar Gain ratio is used to measure the effectiveness of spectrally selective glazing and equals visible light transmittance divided by solar heat gain coefficient.

Visible Transmittance (VT)

Visible transmittance (VT) is the visible light percentage that passes through a window or other glazing units. Also, it represents the point of opening that lets natural light pass through. Solid walls would have a 0 % of VT, where any empty opening would have 100%; various plastic materials and un-tinted glass have VT values of 90% or more. The use of more lighting is usually not useful, as it could be base of overheating. Using coating, tints and frits can produce any visual transmittance; common VT values are regularly within range of 30-80% (Autodesk, 2015). There are factors that affect visual transmittance such the number of glass layers, glass colour (transparent glass has the highest VT), and coating materials. Visual transmittance can be expressed relative to frame, glass or the glass portion of glazing unit. The proper expression will be subject to the analysis nature.

3.6 BUILDING ENERGY CALCULATION METHODS

In general, buildings consume energy, designing sustainable buildings that also fulfil the minimum requirements for all operation of the users is an unprecedented challenge. Designers are faced with enormous challenges due

to the need to recognize and take account of various dynamic processes. Managing all of these aspects in order to accomplish energy efficiency objective, building designers and decision makers need effective design tools to analyze and understand such complexity behaviour of building energy consumption. The following sections give insight in the theoretical background of building performance simulation in the field of operational energy for the calculation methods and energy performance simulation programs.

The operational energy demand for space is guided by interior temperature fluctuations. These fluctuations are based on non-stationary heat transfer process, meaning that temperatures and heat fluxes vary in time. The calculation of non-stationary heat transport under realistic outdoor climate conditions is a complex problem involving manifold parameters. Energy modelling mainly depends usually on two approaches: simplified semi-static methods and detailed dynamic methods (Degelman & Soebarto, 1996). The simplified methods are used to evaluate the response of the building to the surrounding environment and internal heat gain by using average weather data and interior loads (lighting and appliances). These models avoiding details so they have the advantage of being fast, whereas they sacrifice accuracy in the energy predictions especially when subjected to large hourly fluctuation.

The other method of modelling, the detailed methods perform a whole calculation of building heat loss/heat gain each hour of the year. This method covers exact sun angles, temperature, humidity and wind speed on an hourly basis as well as the effects of thermal storage and time in the buildings' indoor. The use of such detailed calculations enable designers to utilize the properties of internal thermal mass computerized thermostatic controls, solar shading devices, occupancy sensors, the control of daylighting dimmers and any other

time dependent parameters. On the downside, these calculations are rather time consuming. Therefore, the use of simplified methods is often preferred in early design stage analysis (Heidegger, 2013). The energy calculation speed and accuracy is the most concern of building energy performance during the conceptual design phase, while their parametric natures close to real time response.

- **One node thermal model**

In this model, the heat storage in internal walls, ceilings and floors is represented by one mass node. The temperature of this node is assumed to be equal to the indoor air temperature. Figure 3-7 shows a schematic representation of the physical room model.

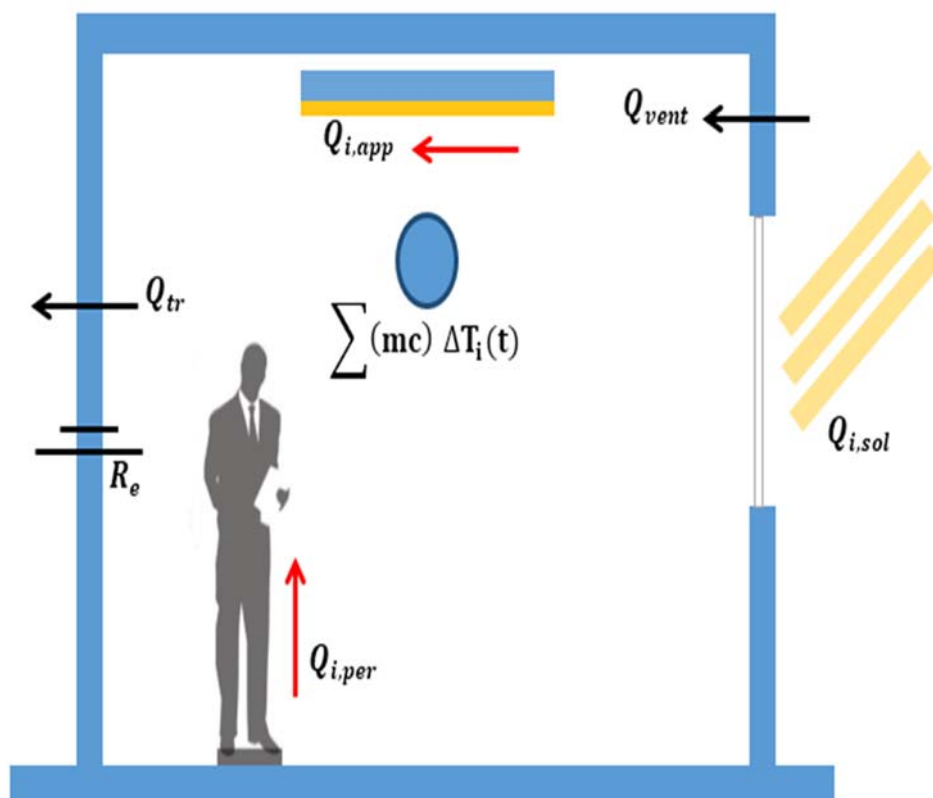

Figure 3-7: One node thermal model (Heidegger, 2013)

The heat balance for this one node model at the time (t) is as following Equation 3-4 (Heidegger, 2013).

$$Q_{sol}(t) + Q_{int}(t) - Q_{tr}(t) - Q_{vent}(t) - C \frac{dT_i(t)}{dt} = 0 \quad \text{Equation 3-4}$$

With

$$Q_{sol}(t) = q_z(t) * g_{gl} * A_{gl}$$

$$Q_{int}(t) = (q_{per} + q_{app}) * A$$

$$Q_{tr}(t) = \frac{(T_e(t) - T_i(t))}{R_e} = (T_e(t) - T_i(t)) * \sum (U_e * A_e)$$

$$Q_{vent}(t) = q_v * pc_a * (T_i(t) - t_e(t))$$

$$C = \sum (m * c)$$

Where:

T_i internal temperature (°C)

T_e outside temperature (°C)

R_e thermal transmittance of the external closure $\left(\frac{m^2K}{W}\right)$

Q_{int} internal heat loads (W)

Q_{sol} incoming solar radiation (W)

Q_{int} heat transmission to external surroundings (W)

U_e heat transmission coefficient of the external closure $\left(\frac{W}{m^2K}\right)$

A_e Area of the external closure (m²)

c specific heat capacity $\left(\frac{\text{J}}{\text{Kg K}}\right)$

m mass being heated (Kg)

q_v room ventilation flow with outside air $\left(\frac{\text{m}^3}{\text{s}}\right)$

q_{per} internal heat production by persons $\left(\frac{\text{w}}{\text{m}^2}\right)$

q_{app} internal heat production by appliances $\left(\frac{\text{w}}{\text{m}^2}\right)$

ρc_a volumetric heat capacity for air: 1200 $\left(\frac{\text{J}}{\text{m}^3\text{K}}\right)$

g_{gl} solar energy transmittance of glass

Most differential equations encountered in practice are more complex than the given equation (Heidegger, 2013). For these cases, analytical methods become very cumbersome. Therefore, numerical methods are generally preferable, if they show to have an acceptable accuracy.

- **Thermal Analysis Model**

Hensen & Lamberts (2011) defined the thermal load of a building as the amount of heat that must be removed (cooling load) or added (heating load) to maintain a constant indoor air temperature. Generally, the building is divided into zones which are assumed to have the same internal air temperature approximately. Each zone represents a control volume over which the heat transfers into and out of the zone is analysed. The analysis process includes all types of heat transfer (convection, mechanisms and radiation) within the building envelope and between the building envelope (walls, roof and floors) and its surroundings. The model ensures that all energy flows are balanced using conventional equations for energy balance of the zone air and the exterior and interior wall temperatures of the building envelope. At the early design stage, (conceptual design phase) the heat transfer

analysis of the whole building can be simulated as one thermal zone. Furthermore, at later design stages, the one thermal zone will be subdivided into smaller zones, when decisions about HVAC systems and their capacity have to be made.

- **Heat losses**

The outdoor temperature (T_e) is given by site specific climate data. These data are retrieved from weather files, which are part of an extensive library containing numbers for more than 2100 locations (U.S. Department of Energy). World Meteorological Organization region and country arranged all weather and provided hourly over the course of a year. The heat transfer rate through the building envelope depends on its thermal resistance, which in turn is a material specific property. In the construction industry, the thermal resistance is usually expressed by R-Value [Km^2/W] or U-value [$\text{W}/\text{m}^2\text{K}$]. The thermal resistance of building material is derived by the following equation:

$$R = \frac{1}{K} * d \quad \text{Equation 3-5}$$

Where:

K is the thermal conductivity

d is the layer thickness

The U value in turn is inversely proportional to the sum of resistance:

$$U = \frac{1}{(R_e + R_i + R_1 + R_2 + \dots)} \quad \text{Equation 3-6}$$

Where:

R_e is the fixed external resistance

R_1 is the fixed internal resistance

R_1 is the sum of all resistance of the construction element

The minimum ventilation requirement $q_{v,min}$ is prescribed by building regulations dependent on the building function (Heidegger, 2013):

$$q_{vent} = q_{v,inf} + q_{v,min} \quad \text{Equation 3-7}$$

Where:

$q_{v,inf}$ is the specific air flow resulting from infiltration.

$q_{v,min}$ is the specific air flow of entering outside air to be heated.

- **Heat gains**

Besides these heat losses, a building is also subjected to heat gains. These can be subdivided into internal and solar gains. The internal gains originate from the heat output of people (latent gain) and of appliances (sensible gain), which in turn depend on the building function and the population density per floor area. The determination of solar gains is a more complex matter. The weather files include information about Global Horizontal Radiation on the specific location. In order to determine the part of radiation incident on randomly orientated surface some angular projections have to be performed. The solar power received by surface is represented by the component of the incident solar radiation, which is perpendicular to the module surface.

- **Energy Assessment**

The total operational energy demand is considered as the sum of energy expense for cooling, heating, artificial lighting and appliances.

- **Heating/cooling demand**

The energy demand is determined for cooling and heating by adding an energy input to the one node model, balancing the heat flows maintain a constant internal air temperature (cooling set point or heating set point temperatures). Recalling Equation 3-4 and adding this energy input Q_{dem} to be as follow (Equation 3-8).

$$T_i(t + \Delta t) = T_i(t) + \frac{Q_{i,tot} + Q_{dem} + H_{tot} * (T_e(t) - T_i(t))}{H_{tot}} * \left[1 - \exp\left(-\frac{H_{tot}}{C}(\Delta t)\right) \right]$$

Equation 3-8

H_{tot} total heat losses $\left(\frac{W}{K}\right)$

Q_{dem} heating/cooling energy demand (W)

Q_{tot} total operational energy demand (W)

Since the specific HVAC system is not yet defined, it is assumed that the system capacity will be sufficient to deliver the energy needed to heat up the room comfort temperature (temperature set point).

So if $T_i(t + \Delta t) = \text{specific temperature set point}$ all parameters are known and the energy demand can be calculated as follow (Equation 3-9):

$$Q_{dem}(t + \Delta t) = \frac{[T_i(t + \Delta t) - T_i(t)] * H_{tot}}{1 - \exp\left(-\frac{H_{tot}}{C} \Delta t\right)} - Q_{int}(t + \Delta t) - Q_{sun}(t + \Delta t) + H_{tot}(T_i(t))$$

Equation 3-9

- **Artificial Lighting Demand**

The daily energy consumption for lighting can be expressed as presented in Equation 3-10 (Heidegger, 2013):

$$Q_{aux,l} = \sum_{h=1}^{wh} \sum_{n=1}^P f * A_n \quad \text{Equation 3-10}$$

With:

$$f = 0 \quad \text{If } (E_{set} - E_n) \leq 0.$$

$$f = \frac{(E_{set} - E_n)}{\eta_1 * K_l} \quad \text{if } (E_{set} - E_n) > 0$$

Where:

$Q_{aux,l}$ is the daily energy consumption for lighting [Wh]

E_{set} is the minimum required level of illumination [lux]

E_n is the hourly level of illumination on analysis point [lux]

η_1 is the efficiency of lighting system [%]

K_l is the visual efficiency of lighting system $\left[\frac{lm}{W}\right]$

wh is the number of working hours

P is the number of sub surfaces (analysis points)

A_n is the area of sub surfaces [m^2]

- Home Appliances (Equipments) Demand

The energy consumed by a specific appliance is calculated as follow (U.S. Department of Energy)

$$\text{Dialy Consumption} = \text{Wattage} * \text{Hours Used Per Day}$$

$$\text{Equation 3-11}$$

Multiply the result of Equation 3-11 by the number of days of the appliance use during the year for the annual consumption calculation as follows:

Appliance	Watts	Hours per Day	Days per Year	Consumption (KW)
Radio	400	4	365	584
TV 36"	133	6	280	224

From the previous, it is clear that the energy calculation is based on thermodynamics equations, assumptions and principles which make this process very complex needed a huge effort for studying and calculating, as well as its relation with building life cycle. So, there is an essential alternative solution to use building energy simulation programs for analysis, performance and thermal evaluation.

3.7 ENERGY PERFORMANCE SIMULATION

Energy performance simulation are effective analytical tools to study the energy consumption of buildings and their thermal comfort for evaluation of building design (Samaan, et al., 2016). Currently, there are many available tools, which differ in various ways such; their user interfaces, purpose of use, thermodynamic modelling, applicability of life cycle utilization and their interoperability with other design applications. Thermal simulation tools use simulation engines, which allow comprehensive thermal simulations such simulation engines include thermodynamic and mathematical algorithms that could be used in energy performance calculation reference to the underlying model of the engine (Maile, et al., 2007).

Today, two types of simulation tools are being utilized; design tools, which mainly focus on the HVAC equipment size and thermal simulation tools,

which evaluate the building performance. These tools generally evaluate the energy usage for different design options based on thermodynamic equations with dynamic calculations. Design tools construct the thermal calculations based on the worst-case scenario to allow designers to select the size of HVAC equipment. This study concentrates on the applications, which are used during the conceptual design stages and that can be utilized to exchange data with other software's. The energy simulation tool used in this study is based on the EnergyPlus simulation engines, the importance of this engine is highlighted by 46,000.00 downloaded copies and the accessibility of 1,250.00 weather locations worldwide (DOE, 2007).

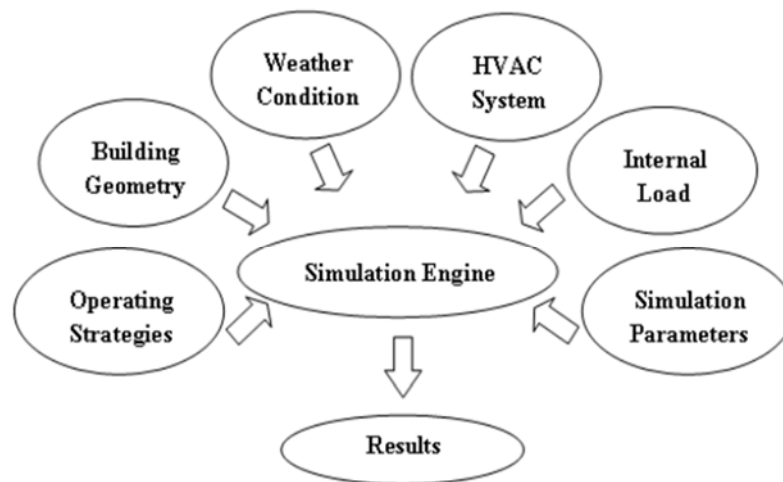

Figure 3-8: General data flow of simulation engines

3.8 BASIC PRINCIPLES OF ENERGY SIMULATION

Energy simulation software packages are mainly designed to evaluate both building energy performance and occupants' thermal comfort. Generally, they can be used to understand how a given building operates reference to definite criteria and allow designer to generate different design options. There is a need to understand energy simulation basic principles. Initially, the accuracy of simulation results can be as precise as the simulation input data. Figure 3-8 illustrates the simulation inputs, which consist of the building geometry,

weather data, internal loads, operating strategies, HVAC systems and its components and other specific parameters of the simulation process.

- **Building Geometry**

The building geometry is considered as the main input for the simulation process. There is a difference between the building model for the simulation process and the model that was generated by an architect. The simulation model, often referred to thermal model or thermal view of the building model, is a simplified view of the architectural building. One of the difference is that the architecture zones have the ability of being combined into thermal zones for example in open offices, the architectural area can be divided into several different zones. For the simulation process, zones need to be identified by zone boundaries, which basically not the same as architectural walls model. Whereas during the conceptual design stages sometimes both the thermal and architectural model can be nearly identical, the differences increase while design progressive elaboration. Actually, it is a challenge to automate and simplify the process that derive the input geometry from architectural model to thermal simulation (Maile, et al., 2007).

- **Internal and External Load**

Internal and external loads are essential to deliver sufficient data of energy balance for any space. Whereas they are strongly affected by surrounding climate and weather, consequently weather data is collected and statistically assembled to be used in energy performance simulation. The data files are being produced mainly for design reasons and to increase the number of regions and cities around the world. The weather files are not reflecting a specific year, but it could be a reference for a specific location with statistical weather parameters. Sometimes weather data are collected at weather station that are locally close or be measured directly in question at the building during the operation of weather. These loads depend on the behaviour of the

occupants and the actual usage of a space such as loads from people, artificial light and home appliances. It is observable that the internal loads quantity could be assumed for a given space during the simulation process (Maile, et al., 2007).

- **Energy Simulation Assumptions**

Energy simulation inputs, especially weather data and internal loads, are already based on assumptions. Designers should pay attention to understand these assumptions and having the ability of deciding whether they are equitable for their simulation or not. Simulation tools support the design process and allow comparisons of different design options that are valid during any stage of building life cycle. The main stream of energy simulation software packages are founded on some assumption. For example, all building spaces are well mixed. On the other hand, the temperature in each space is considered spatially uniform. Many simulation tools use simplified approaches for natural ventilation and infiltration, which are pressure independent.

3.9 THERMAL SIMULATION ENGINE

The energy simulation information is provided to the engine using an input file with defined format. The simulation engine performs the simulation based on the input file and generates the simulation outputs in one or more output files. The output files cover the information about the simulation itself, simulation results and additional data to evaluate the simulation inputs. Commonly, graphical user interfaces enable modeller easily to generate the input files, perform the simulation and illustrate output results. Because of the difficulty of building energy calculations and predictions, energy simulation software packages are typically used parts, user interfaces, to ease the process of inputting data display of outcomes and interpretation for different user's

needs; the engine that covers the concept of thermodynamic in the procedure of routines and equations (Figure 3-9). During the design phase, energy simulation tool is mostly used to facilitate the process of design by comparing energy usage of different design options. Recent study uses EnergyPlus so that a brief history, functionality and limitations are presented in the following subsections.

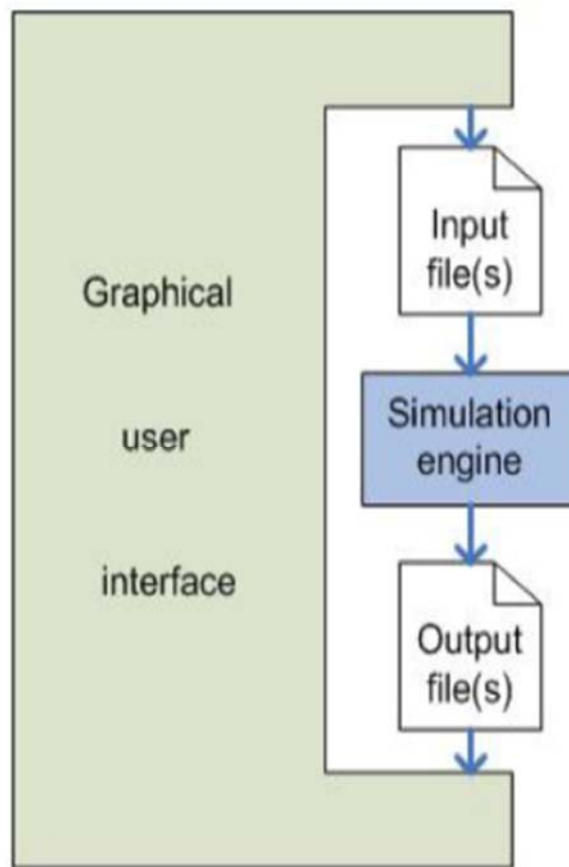

Figure 3-9: General architecture of energy simulation tools (Maile, et al., 2007)

- **EnergyPlus**

EnergyPlus uses Buildings Loads Analysis and System Thermodynamics (BLAST) for energy consumption prediction, system energy performance and cost in building (BLAST, 2003). The actual thermodynamic equations and

procedures are used in BLAST (heat balance method), which gives better results than its counterpart in DOE-2 (weighted heat balance method). EnergyPlus has been developed by Lawrence Berkeley National Laboratory (LBNL), Florida Solar Energy Center and the U.S. Department of Energy (DOE) and Army Construction Engineering Research Laboratory (CERL) (Maile, et al., 2007). EnergyPlus implements the preferred American Society of Heating, Refrigerating, and Air-Conditioning Engineers (ASHRAE) space load calculation method. This method applies the difference of temperatures between materials, construction, and spaces of the assigned thermal zones. The most controlling limitation that EnergyPlus do not have graphical user interface, which provides all capabilities of EnergyPlus. EnergyPlus has been broadly validated and reviewed using the evaluation protocol of ASHRAE/BESTEST (Attia & De Herde, 2011).

Table 3-2: General Features of EnergyPlus (Crawley, et al., 2004)

General Feature	EnergyPlus
Integrated, Simultaneous Solution <ul style="list-style-type: none"> • Integrated Loads/systems/plant • Iterative solution • Tight coupling 	Yes
Multiple Time Step Approach <ul style="list-style-type: none"> • User-defined time step for interaction between zones and environment (15-min default) • Variable time-step for interactions between zone air mass and HVAC system (≥ 1 min) 	Yes
Input Function <ul style="list-style-type: none"> • Users can modify code without recompiling 	Yes
Reporting Mechanism <ul style="list-style-type: none"> • Standard reports • User-definable reports • Visual surface output 	Yes

Table 3-2 summarizes the general features and capabilities of EnergyPlus in simulation process. Table 3-3 illustrates the load features and capabilities.

Table 3-3: Loads Features and Capabilities (Crawley, et al., 2004)

Load Feature	EnergyPlus
Heat Balance calculation <ul style="list-style-type: none"> • Simultaneous calculation of radiation and convection processes each time step. 	Yes
Interior Surface Convection <ul style="list-style-type: none"> • Dependent on temperature and air flow. • Internal thermal mass. 	Yes
Moisture Absorption/Desorption <ul style="list-style-type: none"> • Combined heat and mass transfer in building envelopes. 	Yes
Thermal Comfort <ul style="list-style-type: none"> • Human comfort model based on activity, inside dry bulb, humidity, and radiation. 	Yes
Advanced Fenestration Calculations <ul style="list-style-type: none"> • Controllable window blinds. • Electro-chromic glazing. 	Yes
Windows Calculations <ul style="list-style-type: none"> • More than 200 window types' conventional, reflective, Low-E, gas-fill, electro-chromic. • Layer-by-layer input for custom glazing. 	Yes

3.10 SUMMARY AND CONCLUSIONS

This chapter presented comprehensive discussions about energy performance in residential buildings. Decisions regarding the envelope, orientation, percentage of glazing and construction materials are made during the conceptual design phase. At this phase, however exact data is not yet likely determine. Designers need information to build their energy models using energy simulation software tools, which had the related energy information stored in a library or custom libraries. Once this information is applied to the

model, iterative simulations can be applied to determine the best energy performance for the following:

- Massing scheme.
- Optimal orientation.
- The impact of different construction materials.
- The impact of different windows-to-wall ratio.

Then, this chapter explained the required energy information and its impact on the building energy performance which consisting of many issues for instance: cooling, heating, lighting and electricity consumption, which expressed as building energy demand. The energy demand of building influenced by climate of the surrounding (wind speed, air temperature, moisture and solar radiation), indoor climate and the building function (artificial and natural lighting, sources of internal heat and occupation schedules), building envelope, and heating and ventilation system, lighting, appliances. This chapter presented the energy calculating methods by the thermal equations using one node thermal model analytical, numerical and semi-analytical solutions. It is clear that energy calculations are based on thermodynamics equations, assumptions and principles which make this process very complex. Simulation tools for energy performance are effective analytical approaches to study building performance and thermal comfort for evaluation of architecture design. The best features of energy simulation engines (DOE-2 and BLAST) are used in EnergyPlus, subsequent in a so-called "new generation" simulation engine. This research utilizes the EnergyPlus as an energy engine for the energy simulation, which has high features and capabilities in simulation process.

Chapter 4 ENERGY CONSUMPTION PREDICTION FRAMEWORK

4.1 INTRODUCTION

In response to the research objectives, this study proposed a framework for the development of a methodology to select the most appropriate sustainable building envelope design. The proposed framework consisted of three phases, the first phase is to develop a parametric workflow to determine the energy consumption among different design parameters that affect the energy needs of buildings in response to annual climate and thermal comfort using simulation tools to generate energy consumption database. The second phase is to develop an artificial neural network (ANN) model using the generated database for the subsequent training and testing process that illustrated in chapter 5. The third phase is to develop a generic optimization model to select the optimum design with minimum energy usage based on model constraints and specific parameters that introduced in chapter 6. This chapter introduces the proposed framework components and the energy simulation workflow. In addition, it discusses the role of parametric design, energy simulation, energy performance assessment and the methodology used in the simulation tool to support the calculations of the energy demand in the early design stage.

4.2 ENERGY CONSUMPTION PREDICTION FRAMEWORK

The main objective during building design is to achieve the best equilibrium between the essential design parameters versus a set of criteria that are subject to specific constraints. Conceptual design phase is a creative process that has to provide solutions for ill-defined and incomplete problem requirements (Cavieres, et al., 2011). The conceptual design phase is not only the first step in the design process of a building, but also a crucial decision making phase

that contains all the design requirements. It starts by defining the constraints and requirements on the system imposed by environmental and performance demands and mobilizes all the design elements. In this phase, designers determine the building orientation, building envelope, mass and other parameters. In addition, essential factors for the building energy consumption are determined. Next, the conceptual outline of the design is decided upon, followed by an often-iterative process, the generation and analysis of models and their evaluation, which enables the designer to understand the thermal behaviour of the building affecting the design.

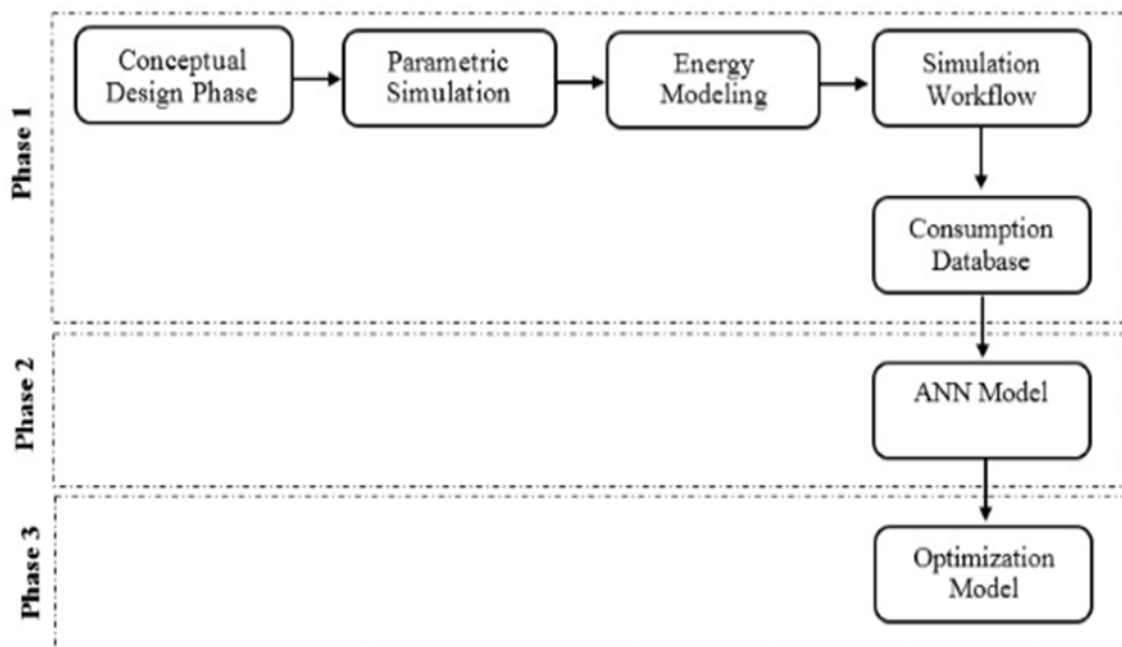

Figure 4-1: Flowchart for the energy prediction framework

In order to generate building energy consumption database to be used in developing energy prediction model linked with optimization engine, a parametric simulation environment is conducting that utilizing a detailed simulation process among different design configurations. Figure 4-1 illustrates a flow chart for the building design optimization framework as well as its components. The various components of the framework are described in the following sections including conceptual design phase, parametric

simulation in design, energy modelling, energy simulation workflow, energy consumption database, ANN prediction model and optimization model.

4.3 PARAMETRIC SIMULATION IN DESIGN

Recently in architecture modelling, parametric design term has been widely used, yet, it is essential to formulate a difference between two different areas where the term is applied. One of them is in regards to Building Information Modelling (BIM), while the other is used within Generative Modelling (GM). During the design process, the two areas has their own implementation approach of the parameter-based models. BIM is specifically geared towards the construction industries as a technique to integrate and facilitate the building's design and construction phases. However, GM mainly focuses on the free geometries with the relation and management of data streams. BIM departs from a body of industry-derived solutions and knowledge. GM departs from a quasi-abstract approach where complicity and freedom seem to be norm (Villamil, 2014). Parametric design is a design approach that deals with the design variables for the geometric properties. The parametric model can display a determinate shape based on defined set of currently chosen parameters. These parameters can be linked together through a set of associations, which allow replaying the logic definitions upon changing of the upstream parameters at any time in the design process. The applications for existing architecture software, GM tools such as Grasshopper, are characterized by allowing the user to synthesize the digital models through algorithms and mathematical functions (Lee, et al., 2016).

In early design stages, simulations used in the construction building industry are difficult to be employed and, therefore, require detailed inputs, which include many unknown variables during design iterations. Recently, parametric simulation techniques utilized as a computing power, a designer

can evaluate numerous prospective designs to produce guidance that design teams can use as an informed starting point for the design process. Parametric simulation tools have been developed distinctively for the early design stage but they present limitations with regard to suitable building types or available design inputs (Samuelson, et al., 2016). Simulation programs application within the design process can differ from regular evaluation by designers who make decisions that influence performance (e.g. an architect who evaluates implications of different window sizes) to a specialist who been instructed by the design team to evaluate a certain design aspect.

4.4 BUILDINGS ENERGY MODELING

Building Energy Modelling (BEM) predicts a building's anticipated energy use and corresponding energy savings, as compared to a standard baseline. In so doing, it demonstrates project compliance with local, regional or national energy codes. BEM predicts energy performance based on Typical Meteorological Year (TMY) data, as well as assumptions about building operation. Accordingly, the prediction is only as accurate as the assumptions, which should be documented and understood by the design team. The energy model is a calculation engine that accepts inputs such as weather data, building geometry, system characteristics, and operations schedules and produces outputs such as performance comparisons and compliance reports as shown in Figure 4-2 (AIA, 2012).

There are a number of factors needed to describe the features of a building being evaluated through energy modelling simulation that impact energy use. The building energy consumed depends on the type of building (whether residential or commercial offices), interaction of spaces and weather conditions. The architectural design parameters based on need and forming, appropriate combinations of these parameters lead to savings of energy

required for maintaining healthy and comfortable indoor conditions. Table 4-1 outlines the levels of modelling parameters and inputs.

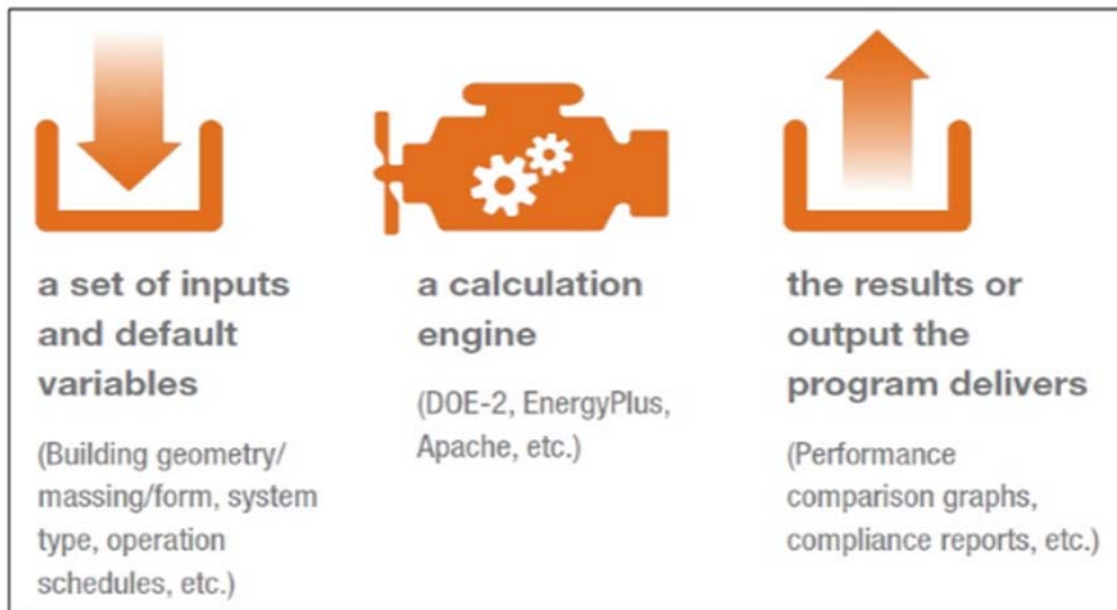

Figure 4-2: Building energy modeling components (AIA, 2012)

Table 4-1: Levels of Modeling Elements and Inputs

Model Parameter	Input Information
Weather Data	Location, Latitude and Longitude and Temperatures
Building Geometry	Building shape, Building orientation, Principal building function, Total floor area and Floor to floor height.
Envelope	Window to wall ratio, Glass (SHGC, U-value, VT), Wall, Roof, Slab on Grade, Thermal zoning and Infiltration assumptions.
Internal Loads	Anticipated building occupancy, Lighting power density and Plug-load density
HVAC Equipment	Systems type (heating and cooling), distribution type, capacity, efficiency and schedules of operation and control.

A brief discussion of the energy modelling inputs associated with each parameter are provided in the next subsections.

Weather Data Analysis

Energy building models use real weather conditions and time data of a particular location to measure the energy consumption. The weather data response to the environmental conditions such as temperature variations, solar trajectories, wind, etc. which are used to define when direct radiation would be desired or not during the year. Egyptian Residential Energy Code (EREC) classified the climate into eight regional zones, which represent moderate, hot semi, and hot arid zones as shown in Figure 4-3.

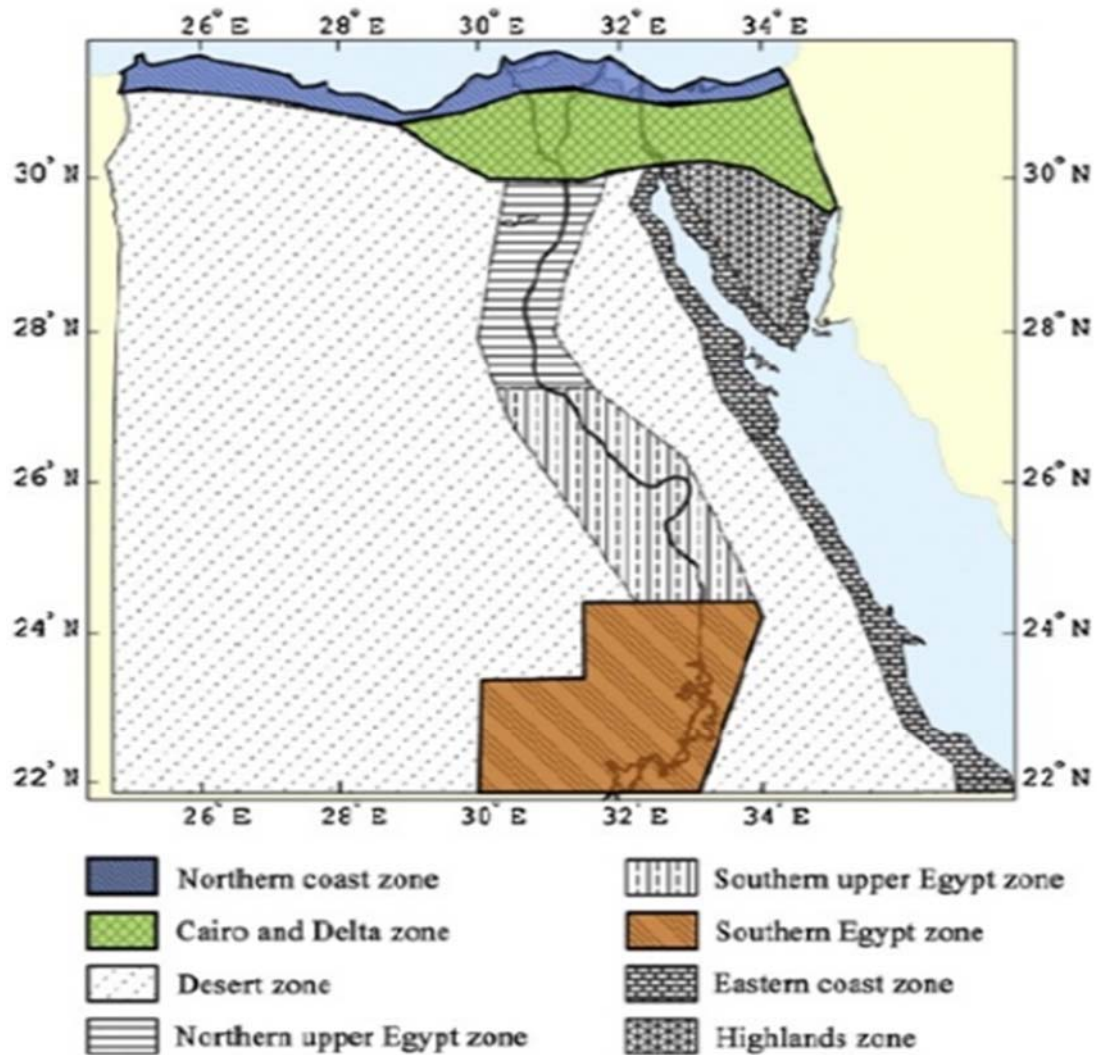

Figure 4-3: Egypt's climatic zones classification map according to (EREC)

Sources of weather data can be obtained through national meteorological services, airports, airfields and publications. The US Department of Energy (DOE) provides typical year weather datasets for more than 2100 worldwide locations in more than 100 countries, some of these are hot humid and hot dry. DOE's weather datasets were used within this research to generate typical weather data provided by the US Department of Energy. There is a synchronize of climate files types and many energy simulation tools support a range of formats. One trend over the last few years is the growth in the number of locations supported by the EnergyPlus Weather (EPW) file format as well as the number of tools that use this format (Crawley, et al., 2001). The weather data format includes the basic location information: location (region), latitude, longitude, time zone, elevation, peak heating and cooling design conditions, holidays, daylight saving periods and typical and extreme periods. Therefore, it is important to determine the location and the used weather data file for energy simulation analysis. The Cairo International Airport weather file supported by the EnergyPlus Weather (EPW) file is used for this study.

Building Geometry

The building shape affect the energy consumed by the building while wind creates pressure differences, positive pressure and negative pressure on the windward side and leeward side respectively. A new airflow pattern is established around the building, which can be modified by shaping it appropriately. This study considers mass rectangular shape with the X, Y and Z dimensions representing the building length, width and height respectively.

Building Orientation

The building orientation is defined by the angle between the building north and the true north measured in degrees from 0° to 360° with clockwise (Figure

4-4). The building north is the direction relative to one side of building while the true north indicated by compass. The best orientation requires that the building as a whole should receive maximum solar radiation in winter and minimum in summer.



Figure 4-4: Building orientation

Building Envelope

A building interacts with the environment through its external façades such as walls, windows, projections, and roofs referred to as the building envelope. The envelope acts as a thermal shell, which if thoughtlessly constructed, would result in energy leaks through every component. The nature of a building envelope determines the amount of radiation and wind that will enter the building. It consists of the following elements:

- Walls
- Roofs
- Slab on Grade (Ground-based floor)

Windows to Wall Ratio

Windows size defined by the windows to wall ratio (WWR). WWR is the ratio of window area to the wall area for each façade.

Glazing Type

Glazing type characterized by the number of panes and coating type applied to the glazing surfaces. Glass U-value, SHGC and VT parameters defined the different windows types (single glass, double glass, low-e double glass etc.,) available for each façade.

Lighting Occupancy and Plug Loads

Lighting systems use the electric energy to provide artificial lighting in the building. The level of light on surface is evaluated by intensity. Lighting type is defined by the lighting power density. The plug-loads affected the balance of cooling and heating loads in the thermal zone of building. For example, increasing plug-loads increase the cooling load and reduced the heating load.

Temperature Settings

Cooling and heating temperatures setting defined by the acceptable indoor temperature needed to maintain thermal comfort.

4.5 ENERGY SIMULATION WORKFLOW

In order to generate annual building energy use database for the subsequent training and testing of the developed ANN model, this study proposed a workflow linked several different tools together to create the parametric simulation model. The developed workflow relates to a building energy simulation including: generating building information data by inputting the building shape, dimensions, orientation, windows properties and construction materials information into a building information input program (Rhino

supporting BIM); linking the building information inputs in middleware (Grasshopper) with thermal energy analysis tool. DIVA for Grasshopper is used for thermal energy analysis, which converts the mapped building shape, orientation and material assemblies into an energy simulation engine (EnergyPlus software). The implementation of the workflow consisted of bridging a set of functionalities to meet each particular need to satisfy the research objective. The creation of the workflow encompassed the existing Grasshopper objects and the creation of customized elements to satisfy some specific needs that are not available with the existing functionalities of the software (Figure 4-5).

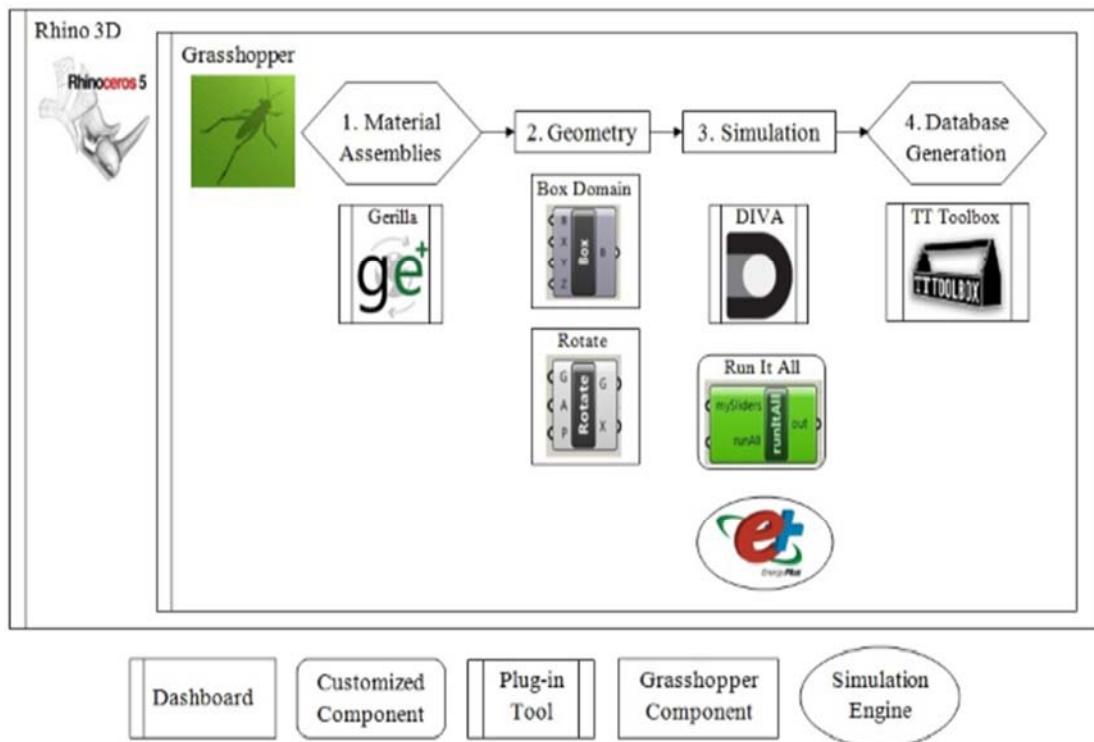

Figure 4-5: Software diagram

The workflow was divided into four main steps that cover the different aspects of the analysis: 1) construction material assembly; 2) the geometry, broken into modelling the building geometry (building shape, dimensions and orientation), and modelling the building windows (windows to wall ratio); 3) the simulations and 4) database generation (Figure 4-6).

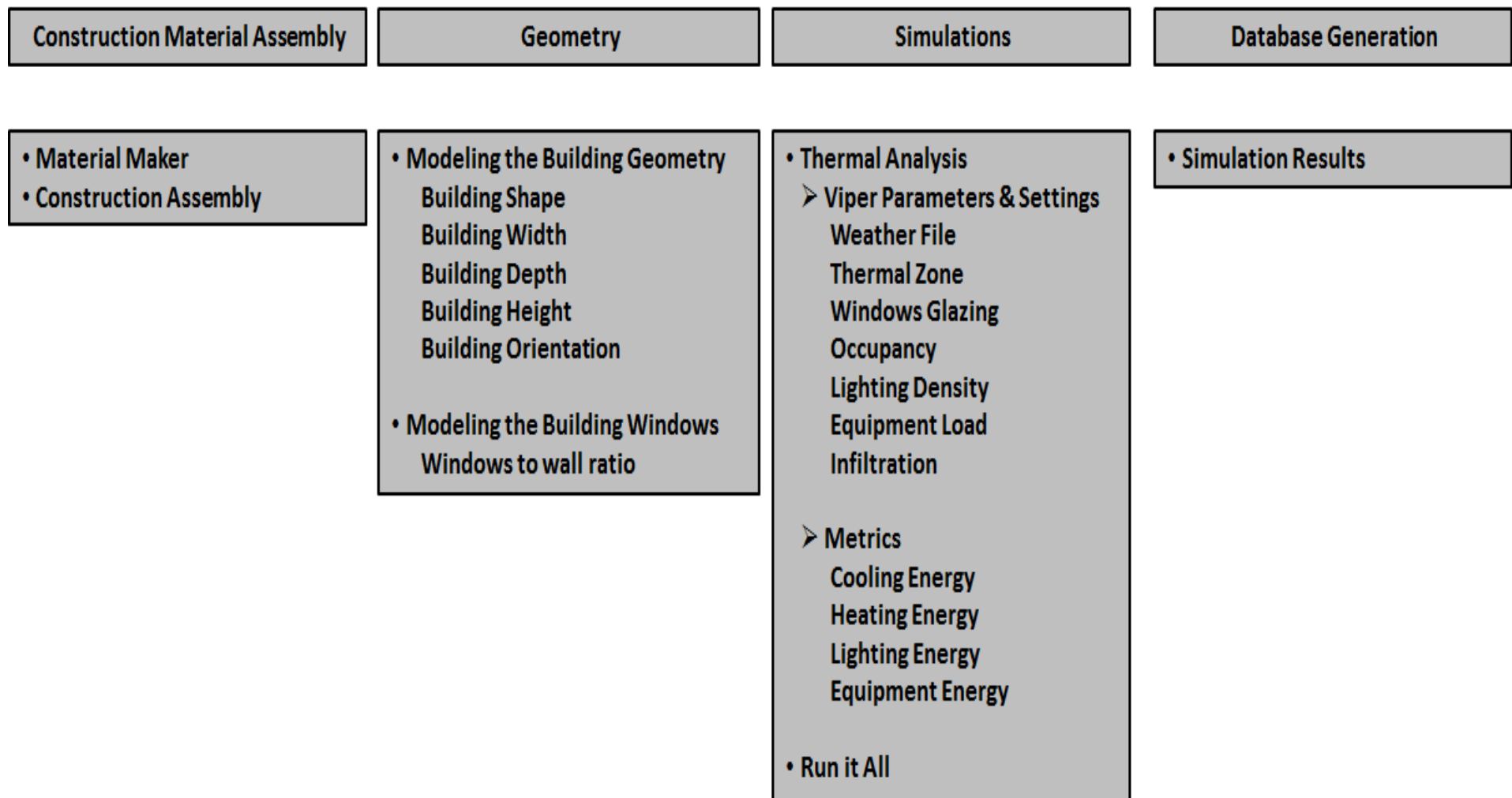

Figure 4-6: The proposed workflow diagram

4.5.1 Step 1: Construction Material Assembly

The properties of material used to make building envelope composition elements (walls, Roof and SOG) in accordance with the Egyptian Specifications for Thermal Insulation Work Items (ETSTIW, 2007) are listed in Table 4-2. The air gap considered no mass with resistance 0.15 m²-K/w.

Table 4-2: The Proprieties of Materials

	Conductivity [w/m-K]	Density [kg/m3]	Specific Heat [J/kg-K]
Red Brick	0.60	1790.00	840.00
Cement Mortar	1.00	1570.00	896.00
Plaster	0.016	600.00	1000.00
Reinforced Concrete	1.44	2460.00	1000.00
Cement Tiles	1.50	2100.00	1000.00
Sand	0.33	1520.00	800.00
Bitumen Damp Insulation	0.15	1055.00	1000.00

Each envelope element can be decomposed into a number of layers. The heat flow through these layers is characterized by their resistance, thermal capacity, absorption, transmission. The materials for these components have to be chosen carefully depending on specific requirements or by energy standards. In 1998 the Housing and Building Research Center (HBRC) Egypt, published a guideline manual for the installation of thermal insulation. The manual included an inventory of most of the thermal characteristics of the building materials used in Egypt. It listed a variety of physical properties including density, thermal conductivity or specific heat capacity data available for Egyptian building materials (Attia & Wanas, 2012). Further, in 2005, HBRC completed the development of the Egyptian Residential Energy Code (EREC).

The EREC standard stated the maximum allowable U-values or minimum insulation R-values for the envelope elements of the building. It also specified the maximum allowable U-factor and Solar Heat Gain Coefficient (SHGC) for glazing as a function of the Window-to-Wall ratio. However, the U-values given for envelope constructions included only roofs and external walls, with no mention of the U-value of floors or ground decks, and only the thermal properties of a limited group of materials were available (Attia & Wanas, 2012).

A. Walls

Walls constitute a major part of the building envelope and receive a large amount of direct radiation. Depending on whether the need is for heating or cooling. The thickness and material of the wall can be varied to control heat gain. The resistance to heat flow through the exposed walls may be increased by increasing wall thickness (Muhaisen, 2015). In this study, three wall types are generated that are representative of the Egyptian typical wall for the residential sector.

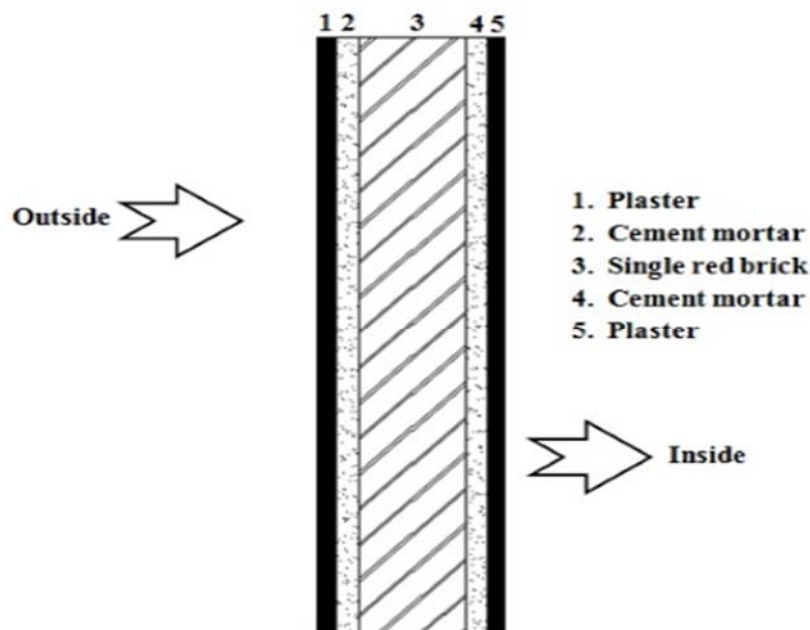

Figure 4-7: Wall Type 1 components section

Wall Type 1

The wall type 1 (single wall 125 mm) is made of one red brick layer, two cement mortar layers and two plaster layers as shown in Figure 4-7.

Wall Type 2

The wall type 2 (Double wall 250 mm) is made of one double red brick layer, two cement mortar layers and two plaster layers as shown in Figure 4-8.

Wall Type 3

The wall type 3 (Double red brick wall with air gap) is made of two single red brick layers, one air gap layer, two cement mortar layers and two plaster layers as shown in Figure 4-9.

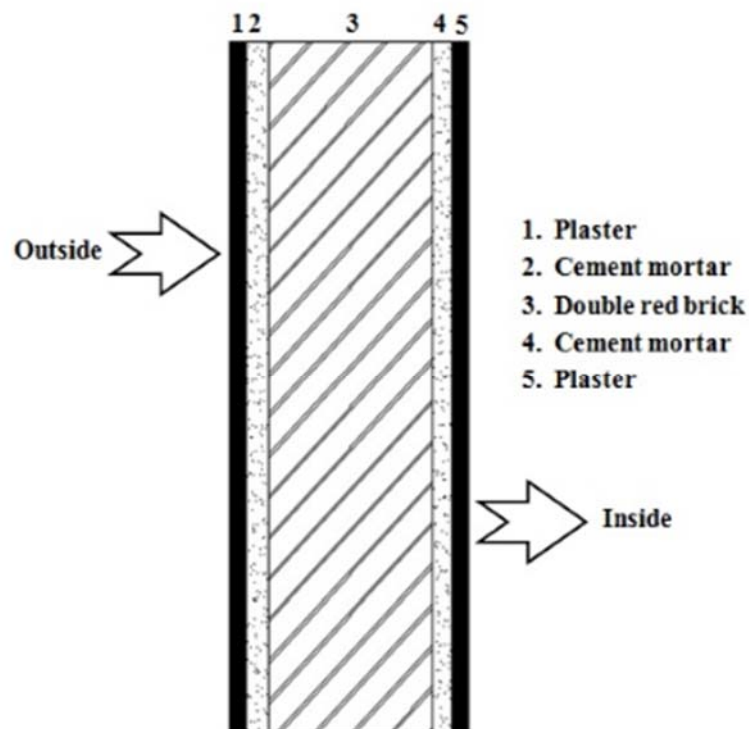

Figure 4-8: Wall Type 2 components section

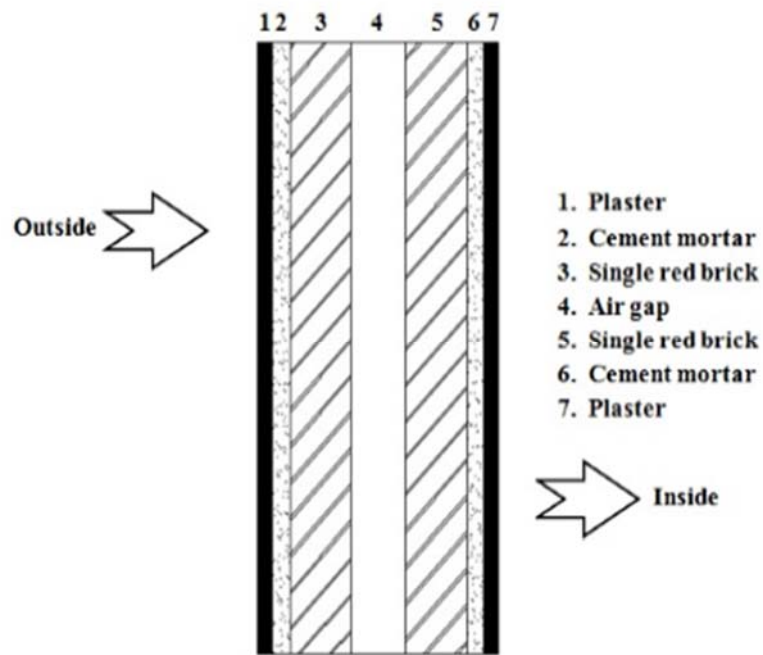

Figure 4-9: Wall Type 3 components section

B. Roofs

The roof of a building receives a significant amount of solar radiation. Thus, its design and construction play an important role in modifying the heat flow through the building. The heat gain through roofs may be reduced by increasing the reinforcement slab thickness and using insulation materials internally or externally to the roofs. As mentioned before, the following roof elements representing the region and specifications used for the building energy modelling:

Roof Type 1

The roof type 1 (Slab 150 mm) is made of one cement tiles layer, one cement mortar layer, one clean sand layer, one insulation bitumen layer and one reinforced concrete layer as shown in Figure 4-10.

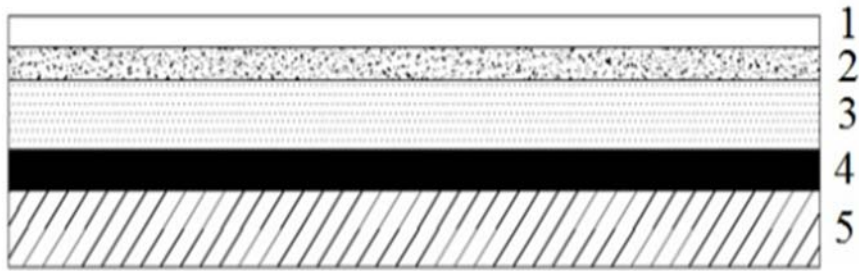

1. Cement tiles (10 mm)
2. Cement mortar (20 mm)
3. Sand (50 mm)
4. Insulation bitumen (20 mm)
5. RC Slab (150 mm)

Figure 4-10: Roof Type 1 component section

Roof Type 2

The roof type 2 (Roof floor slab 200 mm) is made of one cement tiles layer, one cement mortar layer, one clean sand layer, one insulation bitumen layer and one reinforcement concrete layer as shown in Figure 4-11.

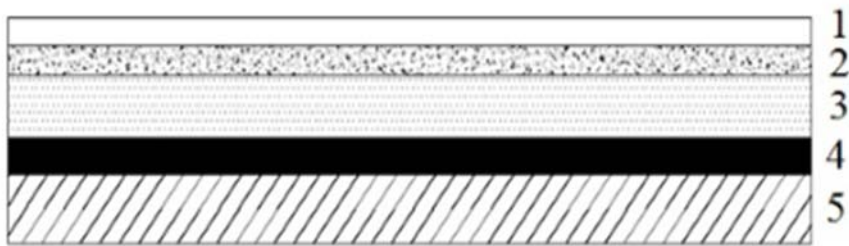

1. Cement tiles (10 mm)
2. Cement mortar (20 mm)
3. Sand (50 mm)
4. Insulation bitumen (20 mm)
5. RC Slab (200 mm)

Figure 4-11: Roof Type 2 component section

C. Slab on Grade

Heat is transferred by conduction from the building to the ground through the walls and floors, which is in contact with the ground. The transfer of heat between the building and the ground occurs primarily via the envelop of the building. The following two types of slab on grade:

Slab on Grade Type 1

The slab on grade type 1 (SOG 150 mm) is made of one cement tiles layer, one cement mortar layer, one clean sand layer and one reinforced concrete layer as shown in Figure 4-12.

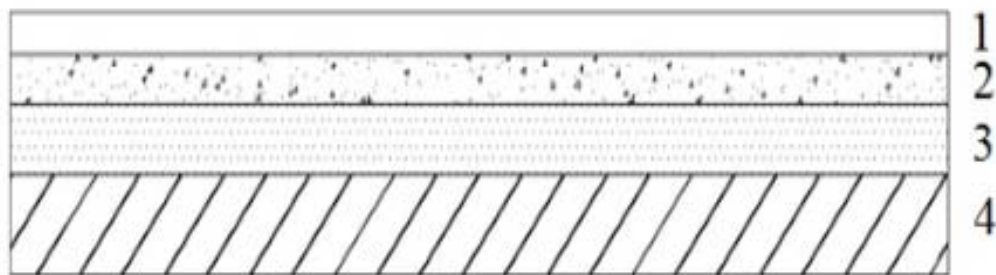

1. Cement tiles (10 mm)
2. Cement mortar (20 mm)
3. Sand (50 mm)
4. RC Slab (150 mm)

Figure 4-12: Slab on Grade Type 1 components section

Slab on Grade Type 2

The slab on grade type 2 (SOG 200 mm) is made of one cement tiles layer, one cement mortar layer, one clean sand layer and one reinforced concrete layer as shown in Figure 4-13.

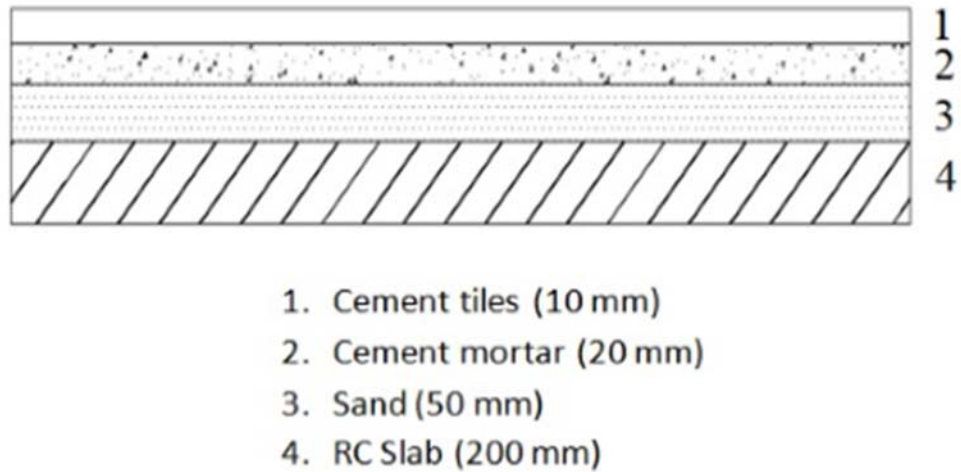

Figure 4-13: Slab on Grade Type 2 components section

The first phase of workflow can be implemented by using Gerilla plug-in for Grasshopper. The material maker Gerilla component is used to create a library of materials that is in accord with thermal and surface properties of the materials in Egyptian thermal insulation specification manual (Figure 4-14). A material is assigned to each layer in the construction element by using Gerilla construction assembly component as shown in Figure 4-15.

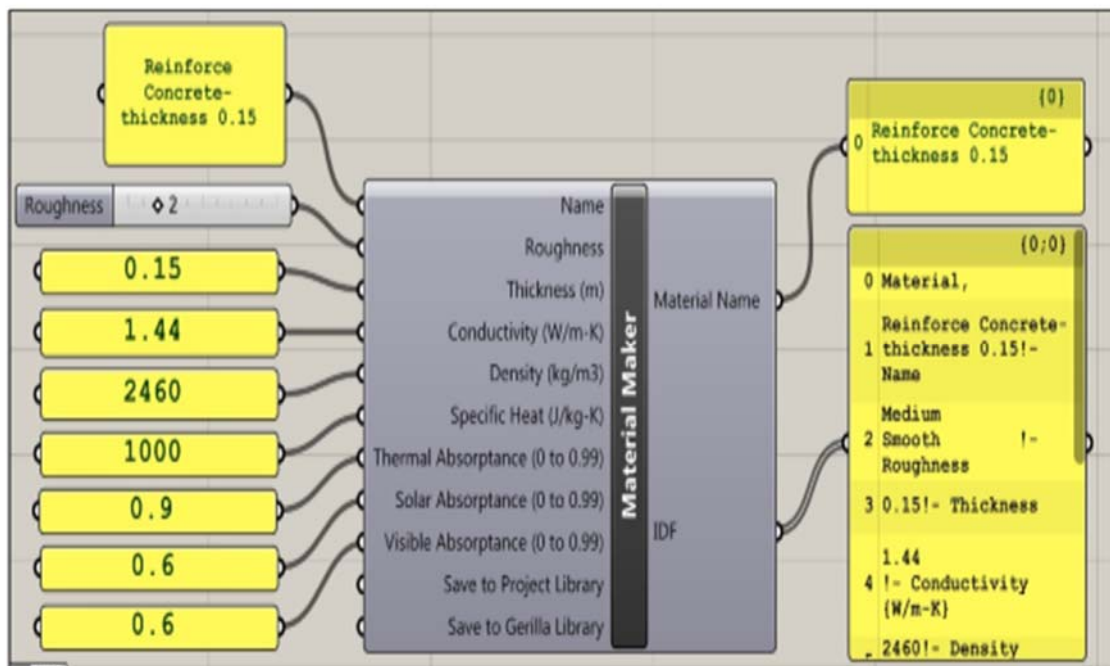

Figure 4-14: Gerilla material maker component

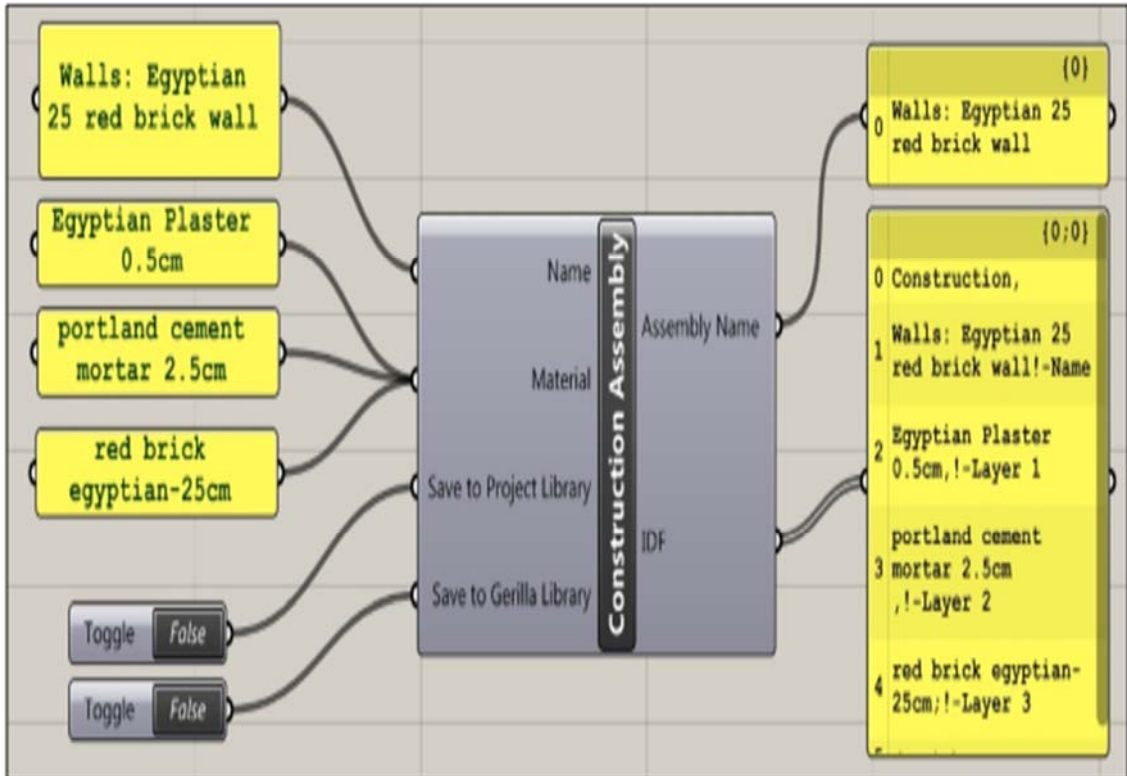

Figure 4-15: Construction assembly Gerilla component

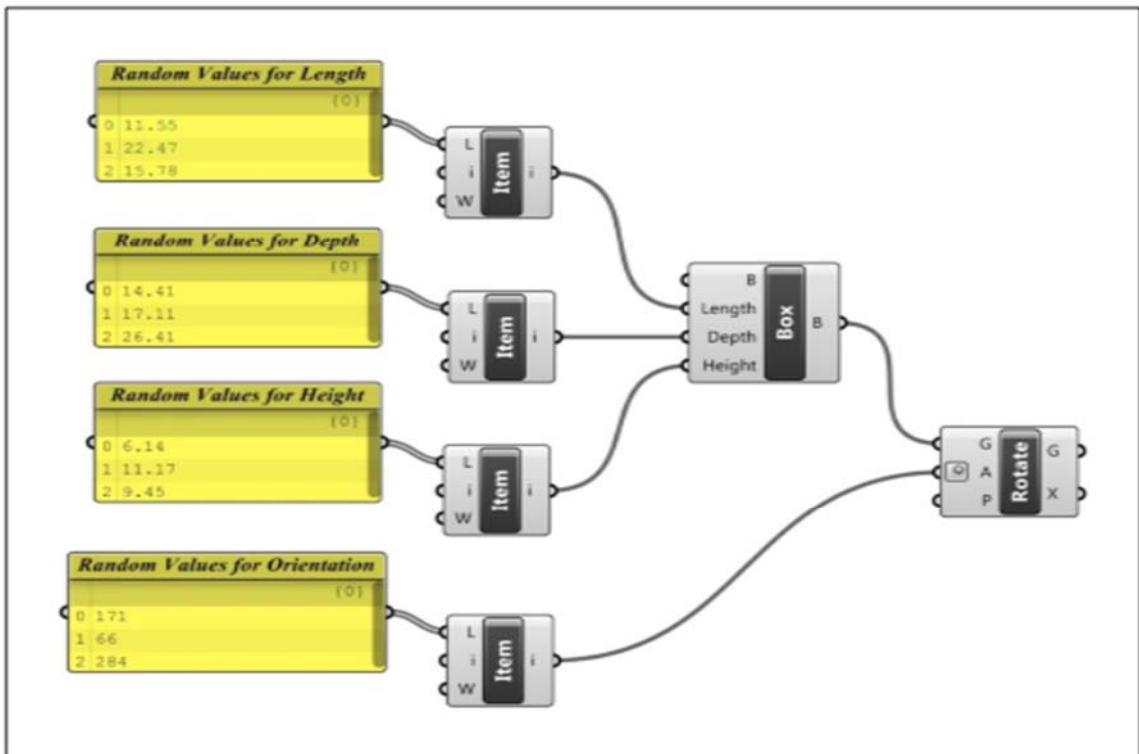

Figure 4-16: Modeling the building geometry

4.5.2 Step 2: Geometry

The second phase of the workflow consists of modelling the building zone that will be simulated. A set of Grasshopper definitions is used to do this (domain box, list items, panel and rotate definitions). The simulation examines an experimental box representing a sample of a single residential building. The parameters that are used to model the building and its zone: building length, width, height and orientation as shown in Figure 4-16.

The next step is to model the windows using Grasshopper components by drawing a new surface over the top of the wall surface for each facade and then changing the size of the new surface to be the size of the windows that represent the window to wall ratio as shown in Figure 4-17.

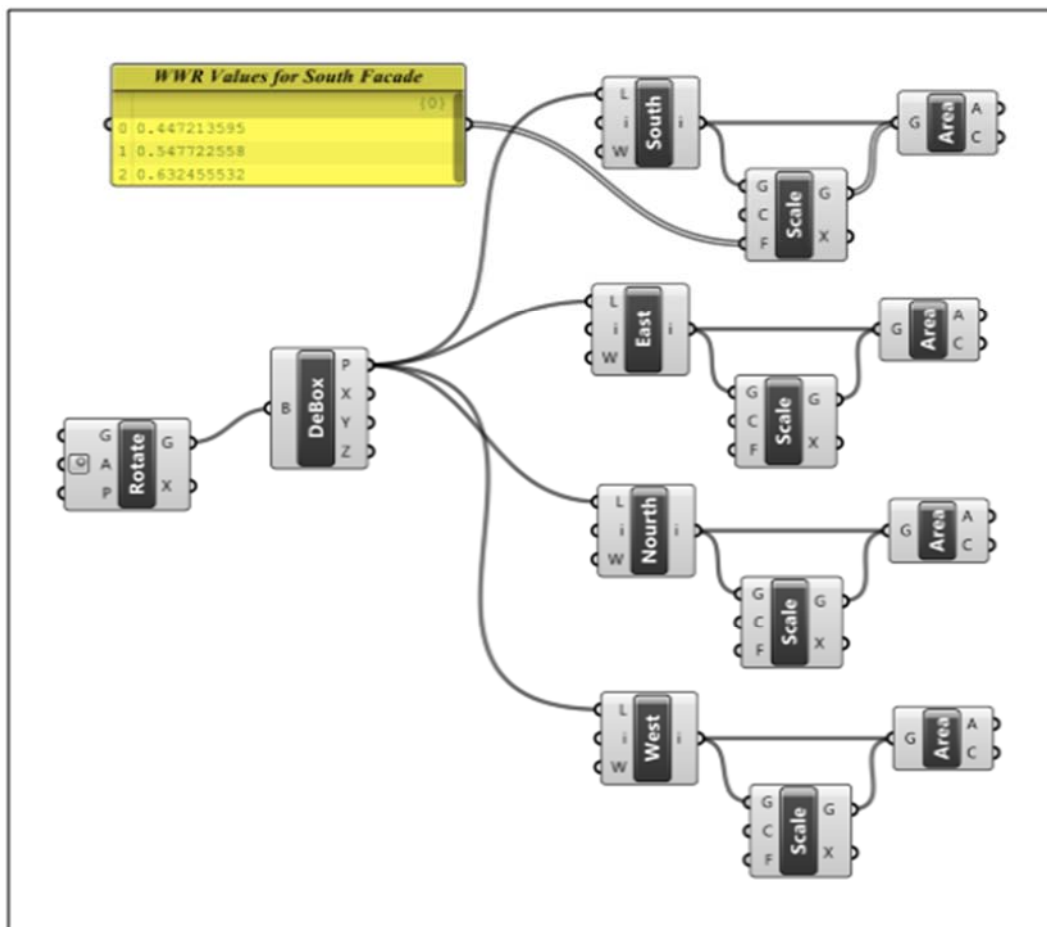

Figure 4-17: Modeling the building windows

4.5.3 Step 3: Simulations

In order to perform the thermal analysis, every permutation of the design parameters is simulated. Many factors affect the energy consumption; this step is primarily concerned with selecting what parameters will be considered for describing the whole building simulation. With the selected parameters, it is then required to determine the level of each variable. In this study, the building envelope consists of 3 types of walls, 2 types of roof and 2 types of SOG. These parameters have discrete values representing the U-value for each element of the building envelope. Other parameters are considered as continuous within minimum and maximum range of values and the default settings for simulation tool were used as illustrated in Table 4-3.

Table 4-3: Parameters values

Input Values	Option	Type	Parameter Value
Building dimension	Length	Continuous	Min. 10.0m Max. 30.0m
	Depth		Min. 10.0m Max. 30.0m
	Height		Min. 3.0m Max. 15.0m
Building orientation		Continuous	Min. 0° Max. 360°
Building envelope	Wall	Discrete	Wall type 1
	Roof		Wall type 2
	SOG		Wall type 3
			Roof type 1
			Roof type 2
			SOG type 1
			SOG type 2
Windows to wall ratio	North	Continuous	Min. 0% Max. 80%
	South		Min. 0% Max. 80%
	East		Min. 0% Max. 80%
	West		Min. 0% Max. 80%
Glazing type	U-value	Continuous	Min. 0 Max. 1.2
	SHGC		Min. 0 Max. 1.0
	VT		Min. 0 Max. 1.0
Lighting Load		Discrete	7.3 W/m ²
Equipment Load		Discrete	7.0 W/m ²
Temperature set point	Cooling	Continuous	Min. 18°C Max. 28°C
	Heating		Min. 18°C Max. 26°C

As mentioned before, the simulation will be performed in EnergyPlus, which allows parametric studies with multiple variables, by generating different scenarios with the given variables and respective levels. In this study, 12 design options for various combinations of wall, roof and SOG construction types were calculated as follows:

$$\text{Number of Design Options} = 3 (\text{Walls}) * 2 (\text{SOG}) * 2 (\text{Roof}) = 12 \text{ options}$$

Each option has discrete and continuous values. Table 4-4 contains the 12- alternative design options. For each design option one thousands simulation is performed random values for the different parameters. Therefore, each design option has 1000 simulations/option with total 12,000 simulations results representing the energy consumption calculated for various designs.

Table 4-4: Alternative Design Options

#	Wall	Roof	SOG
Option 1	Wall type 1	Roof type 1	SOG type 1
Option 2	Wall type 1	Roof type 1	SOG type 2
Option 3	Wall type 1	Roof type 2	SOG type 1
Option 4	Wall type 1	Roof type 2	SOG type 2
Option 5	Wall type 2	Roof type 1	SOG type 1
Option 6	Wall type 2	Roof type 1	SOG type 2
Option 7	Wall type 2	Roof type 2	SOG type 1
Option 8	Wall type 2	Roof type 2	SOG type 2
Option 9	Wall type 3	Roof type 1	SOG type 1
Option 10	Wall type 3	Roof type 1	SOG type 2
Option 11	Wall type 3	Roof type 2	SOG type 1
Option 12	Wall type 3	Roof type 2	SOG type 2

After creating the building zone, the model is ready to be used to perform the simulation process. There are two components-DIVA (for daylight performance analysis) and Viper (for energy consumption analysis). The Viper component is defined for Grasshopper to run thermal analysis based on EnergyPlus simulation engine. Locations, weather files, zone geometry, window assembly, people per square foot, lighting load and equipment load are inputs of the Viper component. The metrics of monthly and annual electric heating, cooling, lighting and equipment consumption can be chosen as an output for different simulation purposes. The Viper component contains construction component to define construction assembly using custom layered material choices and window unit component defined by glazing properties of U-value, SHGC and VT. EnergyPlus can technically perform parametric simulations, but it has a limit of a hundred simulations per run. A customized component was developed in Grasshopper using Python scripting (Appendix 1). The developed component is called "Run All Iterations". As mentioned before, this study has twelve options each option have 1000 simulations, so this component used to iterate between series of sliders which represent the variables parameters. Once the entire attributes as listed in Tables 4-5, 4-6 and 4-7 to perform the analysis are set then the simulations are run.

Table 4-5: Settings for Thermal Simulations

Setting	Attribute
Weather File	EGY_Cairo.Intl.Airport.623660_ETMY.epw
Simulation type	Residential
Run Period	Annual
Time Steps per Hour	6
Outputs	- Heating Energy (Annual) - Cooling Energy (Annual) - Lights Energy (Annual) - Equipments Energy (Annual)

Table 4-6: Constant parameters for thermal simulations

Setting	Attribute
Number of People (people/m ²)	0.033 people/m ² (Attia, et al., 2012)
Lighting Load (W/m ²)	7.3 W/m ² (Ihm & Krarti, 2012)
Equipment Load (W/m ²)	7.0 W/m ² (Attia, et al., 2012)
Cooling COP	3.0 (Ihm & Krarti, 2012)
Heating COP	4.0 (Assad, 2011)
Infiltration Rate	0.7 L/s/m ² (Ihm & Krarti, 2012)
Fresh Air	20 m ³ /h/person (Attia, et al., 2012)
Walls	Wall Type 1 Wall Type 2 Wall Type 3
Roof	Roof Type 1 Roof Type 2
SOG	SOG Type 1 SOG Type 2

Table 4-7: Variable parameters for thermal simulations

Parameters
Thermal zone dimension (Building dimension)
Building orientation
WWR (South, North, West, East)
Glass: U-value
Glass: Solar Heat Gain Coefficient (SHGC)
Glass: Visible Transmittance (VT)
Cooling Set Point Temperature
Heating Set Point Temperature

Figure 4-18 shows the implementation of the simulation process through the Grasshopper for the building modelling, window modelling and DIVIA components for the inputs and outputs definitions.

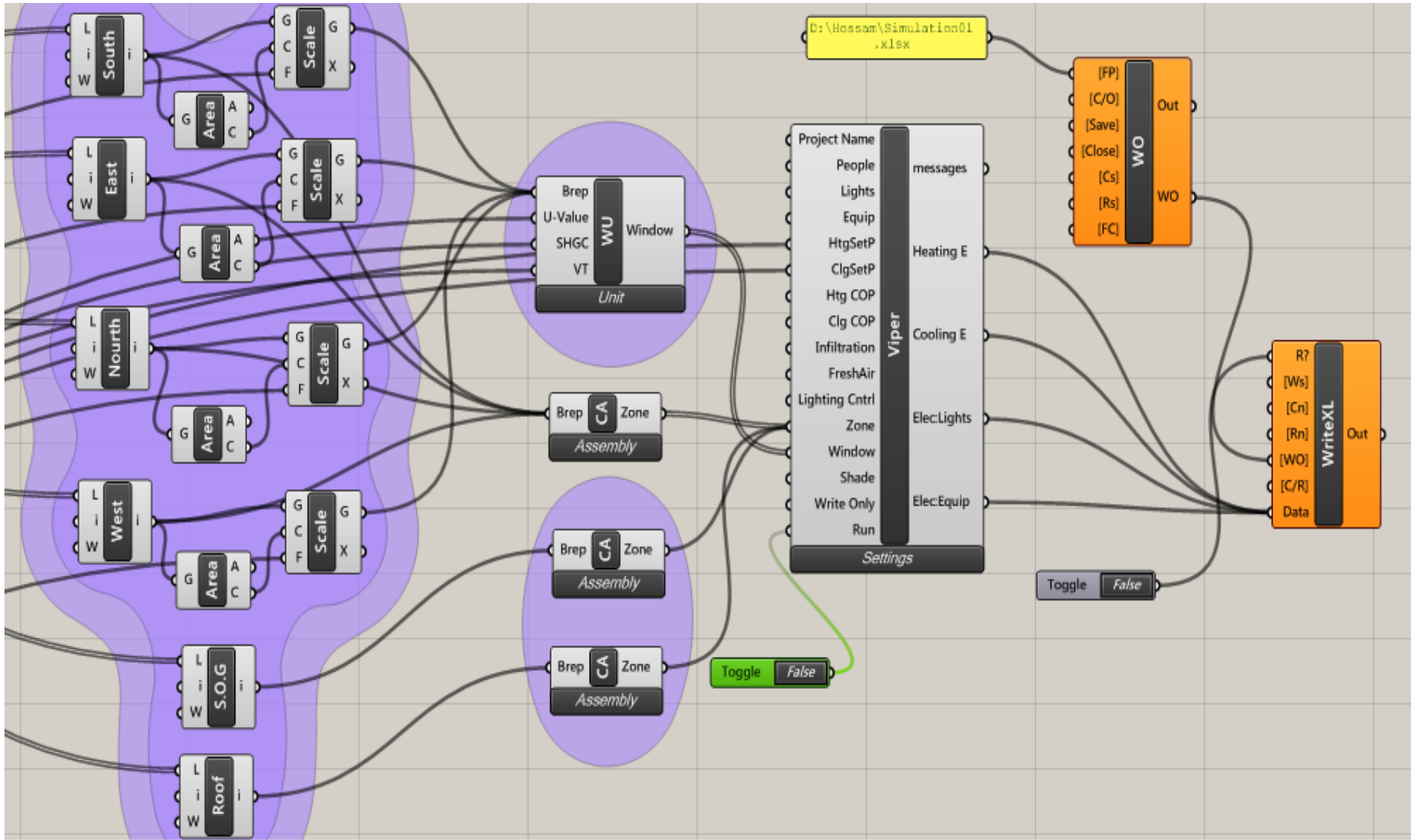

Figure 4-18: Simulation process DIVIA through Grasshopper definitions

4.5.4 Step 4: Simulation Results

During simulation, EnergyPlus saves results for each time step in an output data set and these results can reported at each time step or aggregated to longer time intervals. TT toolbox plug-in for Grasshopper is used in order to gather the input and output data for each simulation/option. In total, 1000 simulations performed for each option with overall 12,000 simulations were performed. These simulations were performed by continually changing parameters' values and all data would be recorded in the whole process. Annual energy consumption for cooling, heating, interior lighting fixtures and equipments results are presented for each option and stored in separate Excel files (Figure 4-19).

	A	B	C	D	E	F	G	H	I	J	K	L	M	N	O	P	Q
1	Wall	Roof	S.O.G	Length	Depth	Height	Orientation	South	East	Nourth	West	UValue	SHGC	VT	Heating_SP	Cooling_SP	pEUI
2	2	0	0	14.98	22.09	11.45	236	13%	19%	18%	76%	0.8	0.73	0.19	20	24	41326
3	1	1	0	20.61	13.09	13.87	224	57%	33%	15%	38%	0.49	0.43	0.08	21	19	57948
4	0	0	0	25.57	29.98	14.66	233	39%	7%	11%	48%	0.43	0.45	0.07	24	19	132729
5	0	0	0	16.26	25.95	12.58	275	22%	9%	27%	44%	0.53	0.08	0.21	19	24	38184
6	0	1	0	28.15	16.24	5.25	99	6%	48%	6%	7%	0.24	0.88	0.58	19	19	59984
7	0	0	0	11.41	24.99	11.76	14	51%	36%	71%	36%	0.29	0.97	0.11	18	28	39740
8	1	1	1	12.33	26.82	14.58	24	63%	21%	19%	56%	0.22	0.44	0.23	18	24	47100
9	2	1	0	23.68	27.03	9.8	316	42%	54%	39%	69%	1.17	0.74	0.22	18	25	70218
10	1	0	0	28.18	23.81	10.35	183	13%	72%	21%	6%	0.86	0.44	0.39	20	24	67471
11	1	1	1	28.06	11.83	10.11	100	71%	40%	1%	2%	0.45	0.4	0.19	24	18	62022
12	2	1	0	23.91	28.64	14.25	285	47%	16%	66%	51%	0.72	0.55	0.53	24	28	53720
13	2	0	0	16.34	12.9	5.15	118	23%	41%	8%	72%	0.32	0.24	0.15	24	19	28162
14	0	0	1	23.12	25.96	8.8	225	12%	72%	7%	50%	0.67	0.61	0.59	22	27	46843
15	0	0	0	21.57	20.4	11.24	239	46%	67%	41%	53%	0.76	0.89	0.79	20	28	45643
16	0	0	1	28.24	23.06	7.96	209	69%	56%	38%	4%	0.91	0.77	0.92	22	20	105068
17	0	0	1	28.71	29.16	12.16	251	47%	60%	70%	15%	0.36	0.85	0.65	20	21	161523
18	0	1	0	16.54	11.4	4.13	218	17%	54%	13%	25%	0.83	0.95	0.65	20	21	25159
19	1	1	1	17.06	17.13	9.43	25	47%	41%	57%	28%	1.14	0.58	0.43	21	27	27540
20	0	1	1	26.62	27.69	7.11	52	2%	48%	34%	46%	1.17	0.37	0.27	19	24	64590
21	0	0	1	15.32	20.61	5.33	272	11%	37%	6%	32%	0.45	0.39	0.79	21	21	34646

Figure 4-19: Inputs and outputs simulation data

Building energy simulation was conducted to generate annual building energy consumption database for developing an ANN-based model that can predict the building energy use for a specific geographic location with the Cairo International Airport whether file. The database is generated through the development of a workflow that performs simulations for calculation of the consumed heating, cooling, lighting and equipment energy. While, predicted Energy Use Intensity (pEUI) describes the energy use for project based on modelled site energy. This study considered that the pEUI is the summation of heating, cooling, lighting and equipment energy consumed in one year measured in watts.

4.6 DATA VISUALIZATION

This section introduces a strategy for visualization of the parametric energy analysis input and output data in order to create an interactive visualization web-based application. This application allows architects/designers to explore the data to provide them with valuable insights to figure out the energy consumption estimation regarding their input data without any need or refer to simulation and modelling tools. Furthermore, one challenge with parametric energy analysis, that it generates large numerical datasets as its output. This is not a format that many architects/designers are comfortable interacting with it. The visualization is used to answer existing questions regarding energy consumption and allow users to interact with it to figure relationships and patterns and to spot outliers, as well as opening up for new questions that may occur when exploring the data. The design space is produced by varying parameters to generate thousands of combinations of inputs for design exploration as shown in Figure 4-19. Multi-dimensional data visualization is an easy and interpretable way and it is one of the key features of Parallel Coordinate Plots. Parallel coordinate plots are a graphic representation of multivariate numerical

data and seeing the relationship between them with every instance in a dataset represented by a polyline that intersects several vertical axes, each axis representing a parameter in the design space. The dataset is generated by performing parametric energy analysis during conceptual design phase using mass building simulated in EnergyPlus. The building differs with respect to the following parameters: wall type, roof type, SOG type, building dimensions (Length, Depth and Width), building orientation, WWR % (South, North, East and West façade), Glass properties (U-value, SHGC and VT), cooling set point and heating set point. These parameters are represented by the vertical axes of the Parallel Coordinate Plots. The dataset comprises 12,000 simulations, aiming to predict one output value of energy use intensity (pEUI).

In Parallel Coordinate Plot, the vertical axes are placed in parallel to each other whereas, each variable represented with its own axis. Each axis can have a different unit of measurement and scale. Values are plotted as sequences of polylines connected across each axis. This means that each line is a collection of points placed on each axis, that have all been connected together. The axes are arranged in a way that the reader understands the data. The downside of Parallel Coordinates that when the design space has very data-dense, the plot become over-cluttered and therefore illegible. To overcome this problem, is through interactively and a technique known as "Brushing". Brushing highlights, a selected line or collection of lines, while fading out all the others. This allows you to isolate sections of the plot you're interested in, while filtering out the noise.

Figure 4-20 shows a schematic depiction of the implementation of Parallel Coordinates Plots for two input parameters and one output as an example with focus

on the Brushing (filtering capabilities). Each attribute provided with interactive range selectors providing the following interaction possibilities:

- (I) Represent the upper boundary of corresponding selection that can be either moved individually or simultaneously.
- (II) The designer can drag the selection range up and down on the axis instead of shrinking or increasing the respective section.
- (III) The lower boundary of respective selection that can be dragged individually or simultaneously.
- (IV) Mouse pointer will high spot only the data items satisfying the presently applied filtering criteria.

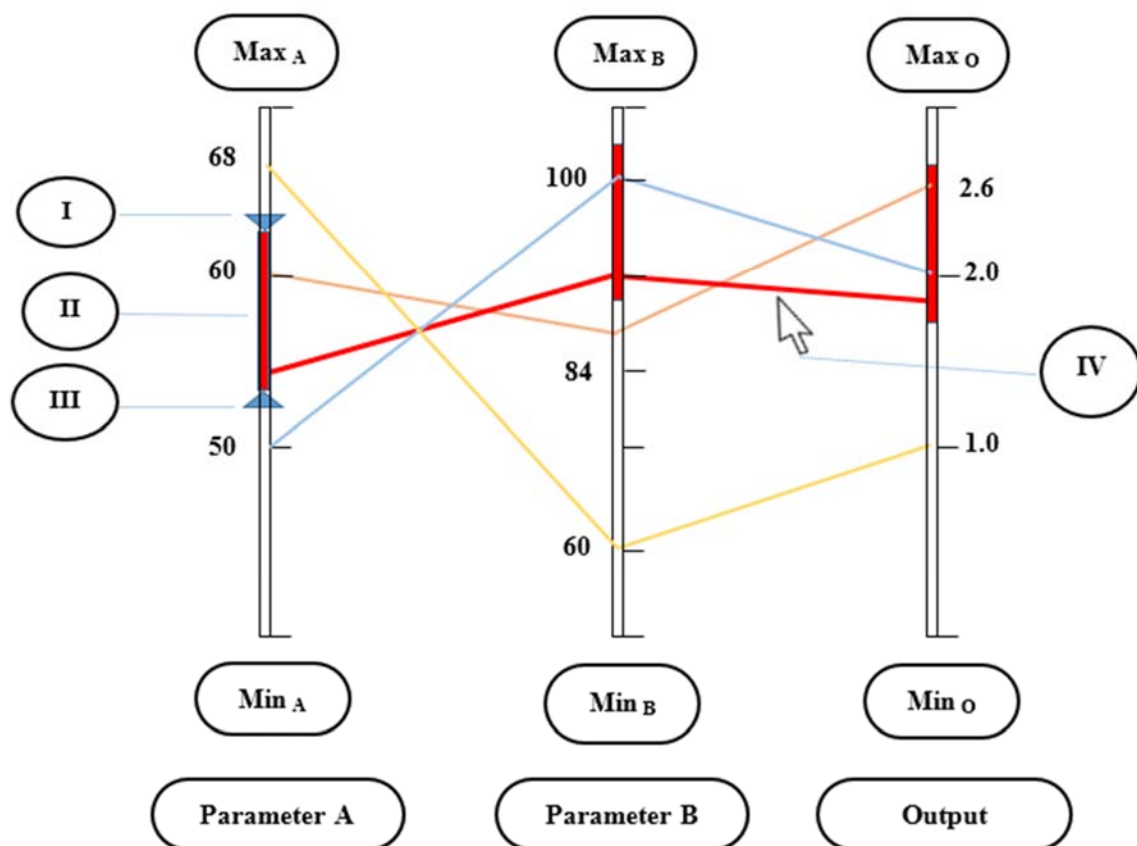
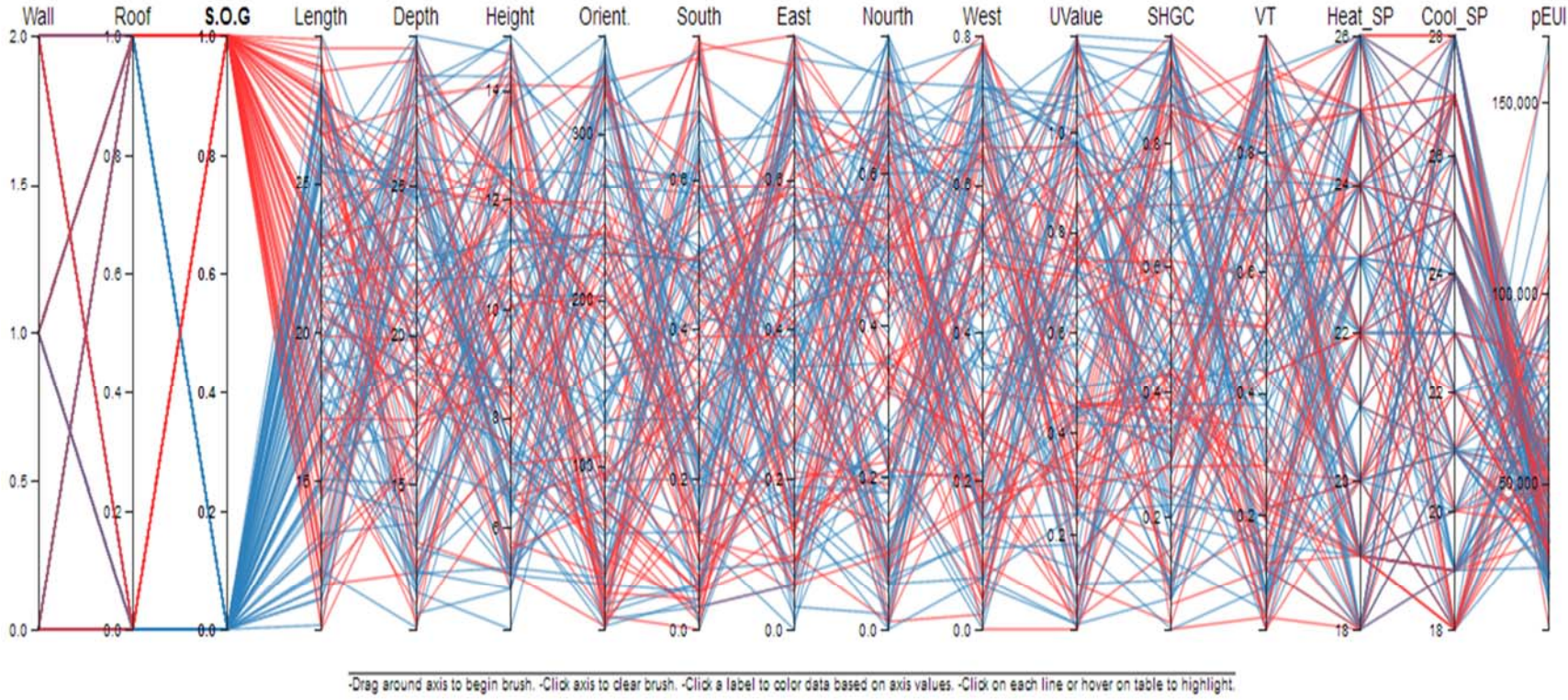

Figure 4-20: Schematic Parallel Coordinates implementation



Wall	Roof	S.O.G	Length	Depth	Height	Orient.	South	East	North	West	UValue	SHGC	VT	Heat_SP	Cool_SP	pEUI
2	0	1	11.55	23.9	8.82	284	0.59	0.39	0.42	0.78	0.27	0.92	0.61	26	28	32924
0	1	0	26.5	12.13	6.86	268	0.58	0.19	0.76	0.43	1.17	0.94	0.04	26	25	40307
2	0	1	21.13	29.75	11.54	157	0.14	0.25	0.49	0.72	0.1	0.03	0.52	26	27	39098
0	1	1	25.96	17.24	8.46	344	0.03	0.68	0.62	0.66	0.84	0.7	0.7	24	28	34349

Figure 4-21: Example of the developed energy consumption data visualization web-based application

The generated data from the parametric energy simulation is recorded into a list, which are saved in (csv) file to be read online. A web-based is designed to explore the possibilities of better data visualization. Figure 4-21 provides an example of the developed web-based interface which allow the designer to identify deign parameters and the corresponding energy consumption.

4.7 SUMMARY AND CONCLUSIONS

This chapter presented the proposed framework for developing energy consumption database for residential buildings. The framework consisted of two main phases: the first phase is to generate energy consumption database by developing workflow utilizes a parametric modelling software with a building energy simulation tool. Parametric modelling has caught the attention of the building industry for its potential of automatically exploring a large spectrum of design options. The second phase will be developing an energy prediction ANN model that is illustrated in the next chapter.

This chapter introduced the first phase of framework and focused on the parametric simulation technique during early design stages. Parametric modelling has caught the attention of the building industry for its potential of automatically exploring a large spectrum of design options. Parametric energy simulation is used to perform thermal analysis for generalized residential building model to simulate all possible design combinations which affect the building energy performance with a total of 12,000+ simulations to calculate the energy consumed for each simulation.

The proposed framework was divided into steps and the outcomes of each step is used as the inputs of next step. The first step is to define the objective as performing thermal analysis during early design stage to calculate cooling, heating, interior

lighting fixtures and equipment energy consumed for a specific location. In order to achieve this goal there is a need to determine design parameters and input values such as building envelope, building dimensions, building orientation, WWR for each facade, glass u-value, VT, SHGC, heating set point and cooling set point. The parametric and energy simulation programs: Rhino, Grasshopper, EnergyPlus, DIVIA, Gerilla, TT Toolbox and customized components were used to demonstrate one possible method of combining design and energy simulation. Once the entire simulation attributes to perform the analysis were set, then the simulations were run and the input parameters values and the simulation output of (pEUI) is automatically generated and stored in a spreadsheet file. Finally, visualization web-based application was developed to be generic and allow user to figure out the predicted energy consumption through different parameters with no experience on simulation or modelling tools.

Chapter 5 ARTIFICIAL NEURAL NETWORK MODEL DEVELOPMENT

5.1 INTRODUCTION

This chapter presents the development of energy consumption prediction model by using artificial neural networks (ANN) for expecting the cooling, lightening and equipment's energy consumption. The basic concept of ANN is easy to understand, there are several issues one should address in designing ANN prediction model. So, several key issues related to applying an ANN model to building energy prediction are examined. The success of the model depends on its ability to capture the desired data pattern. This chapter focuses on how to choose appropriate network structure, training methods, neural network model development. Validation and sensitivity analysis of the proposed ANN model are also, presented.

5.2 ARTIFICIAL NEURAL NETWORK BACKGROUND

ANN is the most commonly applied machine-learning algorithm. ANN is a Response Surface Approximation (RSA) technique, with an architecture based on the human brain. It is a nonlinear dynamic method that involving a large number of highly interconnected processing nodes, called artificial neurons. An ANN is aimed to provide a fast and accurate approximation of a given systems and it have been effectively applied to classification problems or function approximation which are characteristically sparse and noisy with a high level of nonlinear relationship complicity. It was first studied in the late 1940s and later developed during the 1980s. The key computational features of ANN are their capability to learn functional relationships from a given examples, then discover patterns and regularities in data through self-organization, based on a set of inputs and outputs.

Recently, ANN is being functioned to the increasing number of real world problems of significant complexity. ANN is a good pattern with the ability to generalize in making decisions for imprecise input data by recognized engines and robust classifiers. Consequently, several competing hypotheses can be explored simultaneously. ANNs lies in their capability of learning and their resilience against distortions in the input data. In addition, large numbers of complex patterns can be stored because they are not memorized individually and its ability to approximate any nonlinear function (Haykin, 1998).

Neural networks generally consist of many numbers of neurons that are interconnected with each other through weighted association lines to generate the outcome (Bagnasco, et al., 2015). How the connections of inter-neuron are arranged and the nature of these connections determines the network structure. The weight-balance of these lines is done and adjusted during training process of input data that the network uses to adapt its links to achieve a desired overall network behaviour. There are multitudes of different types of ANNs. It can be categorized regarding to their structure and learning algorithms. One of the most common networks include multilayer perception (MLP), which is commonly trained with the back propagation algorithm, radial basis function. Various ANNs are categorized as feed-forward whereas others are recurrent (i.e., implement feedback) depending on how data is processed through the ANN (Pham, 2006). In the following sections, a concise review of the main types of neural networks and the terminology used in describing these networks are presented. A special emphasis will be given to the multilayer-feed forward networks, and the back propagation algorithm as the network structure and the learning algorithm utilized in this study.

5.3 ARTIFICIAL NEURON

An artificial neuron similar simulates four basic functions of a biological neuron. Figure 5-1 shows the model for an artificial neuron. The basic fundamentals of artificial neuron model would be identified according to (Bagnasco, et al., 2015):

1. **A set of synapses or connection links**, each is having a character designed by its own weight or strength. Specifically, a signal x_i at the input of synapse i connected to neuron k is multiplied by the synaptic weight w_{ki} (where k refers to the neuron in question and i refers to the input end of the synapse to which the weight refers).
2. **An adder or summation function**, which is used to determine the input signals summation that constitutes a linear combiner, weighted by the respective synapses of the neuron and producing a linear output u_k .
3. **An activation function**, which is limited the amplitude of neuron output. It defines the output of a neuron in terms of the activity level at its input denoted by $\varphi(\cdot)$. The neuron output can be written $[0,1]$ as a closed unit interval or $[-1,1]$ alternatively.

Mathematically, the artificial neuron may be described as follows:

$$u_k = \sum_{i=0}^n w_{ki} x_i \quad \text{Equation 5-1}$$

$$y_k = \varphi(u_k) \quad \text{Equation 5-2}$$

Where:

x_1, x_2, \dots, x_n are the signals of the input; $w_{k1}, w_{k2}, \dots, w_{kn}$ are the synaptic neuron weights k ; u_k is linear combiner output; y_k is the output signal of the neuron k ; and $\varphi(\cdot)$

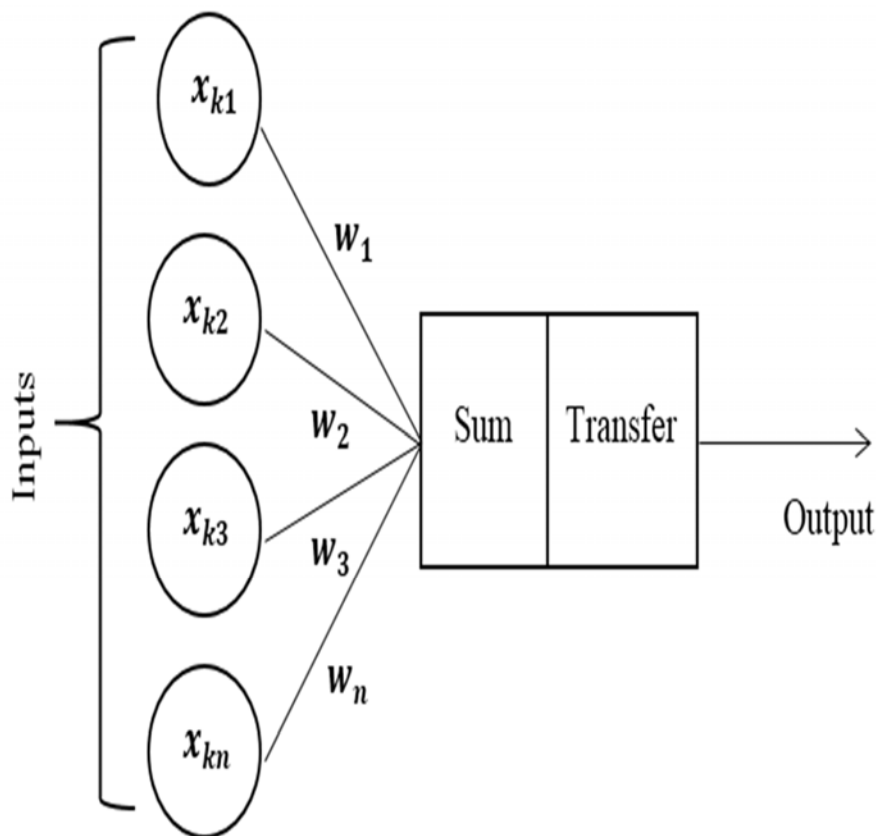
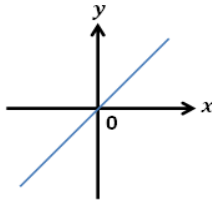
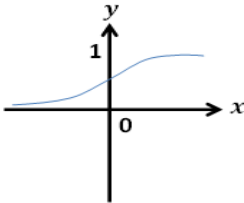
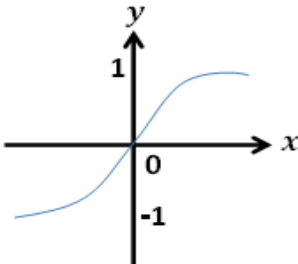

Figure 5-1: Basic artificial neuron

5.4 ACTIVATION FUNCTION

The transfer function for neural networks may be linear or nonlinear function of \mathbf{u}_k and must be differential and continuous to enable correcting errors. A large number of alternative activation functions can be used. The most commonly used functional forms are given in Table 5-1.

Table 5-1: Different activation functions characteristics (Bagnasco, et al., 2015)

Activation function	Description	Mathematical equation	Graphical Representation
Linear	The output is equal to its input	$\varphi(u) = u$	
Sigmoid (logistic)	Continuous, nonlinear, differentiable, and non-decreasing. Squeezes values of the input in a range (0,1)	$\varphi(u) = \frac{1}{1 + e^{-u}}$	
Hyperbolic tangent	Bipolar sigmoid function, which have the binary sigmoid function characteristics. Squeezes values of the input in a range of (-1,1)	$\varphi(u) = \frac{1 - e^{-2u}}{1 + e^{2u}}$	

5.5 TYPES OF ARTIFICIAL NEURAL NETWORKS

Combining two or more artificial neurons, mainly result in getting an ANN. Architecture or network topology is basically the way of interconnecting individual artificial neurons. There is a various ANN models in terms of operation mode and

network topology. However, each model has its own specifications that rely on the following major concepts (Boussabaine, 1996):

1. The set of neurons processing.
2. The activation for each neuron.
3. The network topology or neurons connectivity pattern.
4. The method of propagation that is used to propagate the neurons activities through the network.
5. The rule of activation for updating each node activities.
6. The external environment that interacts with the network and provides it with information.
7. The method of learning that modifies the connectivity pattern by using information provided by the external environment.

Network architecture, also called structure, the point of interconnection, which can be done in several ways to form a variety of network architectures. Neurons in Feed-Forward neural network (FNN) are generally grouped into layers so that information flows in only one way from inputs to outputs. Figure 5-2 illustrates a simple multi-layered ANN with three layers. The network communicates with the surrounding world through the input and output layers' nodes. Whereas, middle layers (hidden layers) give a crucial computational ability to the system. The output vector is computed by a forward pass of the input vector through the hidden layers. There are no limitations on transfer function type, layers number and connections number between neurons. The ANN can be enabled to extract higher order statistics by adding one or more hidden layers. This is particularly valuable when the input layer has a large size (Churchland & Sejnowski, 1992).

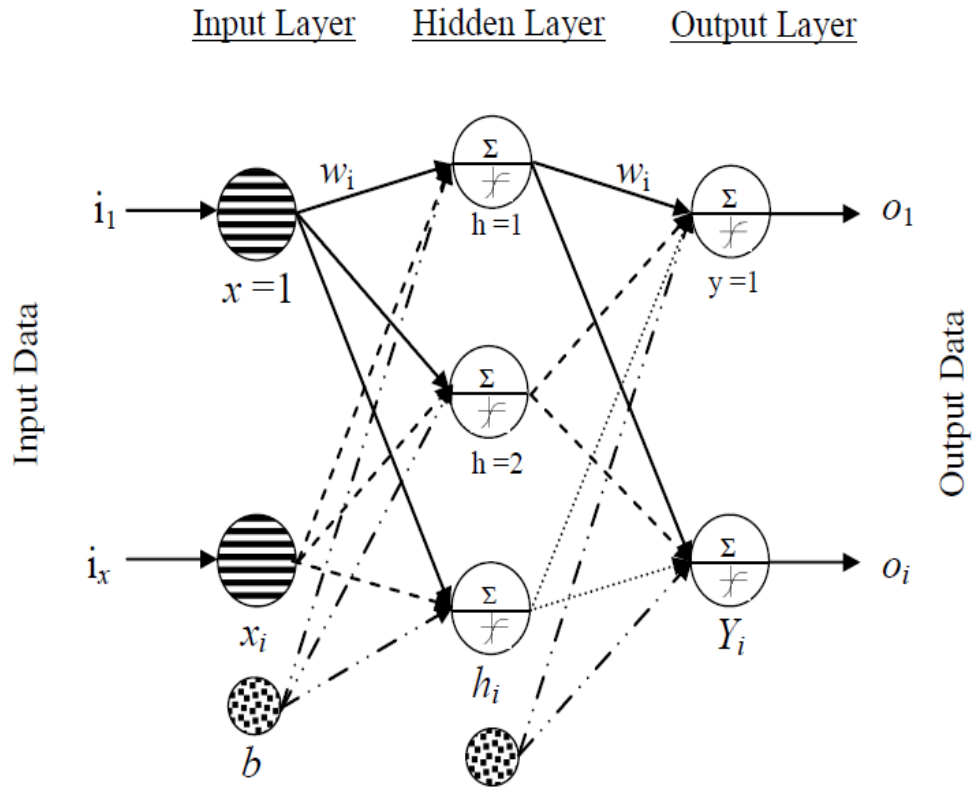

Figure 5-2 Feed-forward artificial neural network

5.6 LEARNING ALGORITHM

The network is ready for learning for a particular application, once it has been structured. At the beginning the initial weights are randomly generated and then the process of learning or training begins, through the many interesting ANN properties, the property which has a primary significance is the network ability to learn and improve its performance during the process of learning from experience. The common major learning paradigm is the supervised learning (Haykin, 1998).

In supervised learning, both the inputs and the output are provided. The concept of ANN learning is to set the parameters values for the value of valid input after having seen the value of output. Then, the network processes inputs and compares the desired output data against the network output results. Then, errors are propagated

back through the network, causing the network to adjust the weights. Training data is processed many times during the training of a network, as the connection weights are over refined.

To solve a given supervised learning problem, there are various steps to be considered as following:

1. Determine training algorithm type.
2. Gather the training data (input and desired output) that satisfactory describe a given problem.
3. Describe the training data set in from understandable to a chosen ANN.
4. Perform the ANN learning process.
5. Test the performance of learned ANN with the test (validation) data set.

5.7 NEURAL NETWORK MODEL DEVELOPMENT

Recently, there are several tools and languages are presented to build ANN models. The development of the proposed ANN model will be using NeuroSolutions version 5, which offers the following features:

- User interface with highly responsive, interactive and intuitive.
- Easy for editing input data using built-in spreadsheets.
- Support sensitivity analysis.
- Dynamic graphics to continually view inputs, weights, states, and outputs in different formats.
- Visualization tools used to illustrate the learning process.
- Ideal for the problem that falls in the domain of financial analysis, predictions, forecasting, classification, decision-making and control applications.

Figure 5-3 shows a systematic approach that is commonly used for the development of an ANN model.

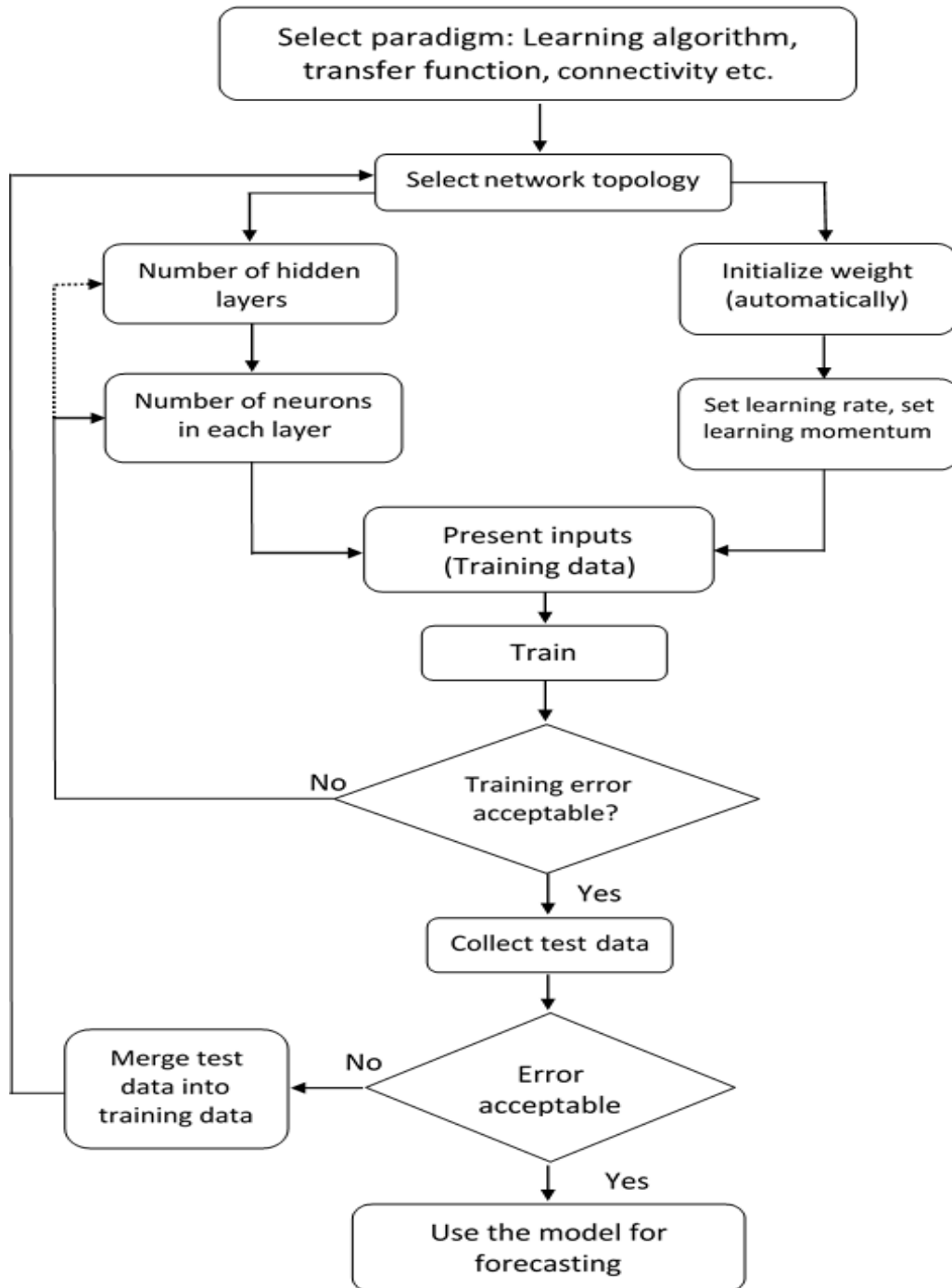

Figure 5-3: A systematic neural network model development process (Boussabaine, 1996)

5.7.1 Training and Testing Pattern

The most important condition that can significantly influence the ability of network for learning and generalization is the number of patterns in the training and testing set. Although it increases the time required to train a network, increasing the number of training patterns provides more information about the potential level of accuracy that can be achieved by the network. Another important factor is that the training data should be well distributed within the problem domain to cover all spectrums of data available in order to identify the best combination of conditions for a particular problem (Günaydın & Dogan, 2004). In this study, a total of 1200 data (from 12000 simulations) sets are used. It is decided to use 60% of the 1200 data sets for the network training (720 cases), 20% of the data (240 cases) for cross-validation in order to improve ANN learning and 20% of the data (240 cases) for testing. Then, 100 cases (from 12000 simulations) different from the previous sets, are used for validation of the network, which randomly selected and extracted from simulated data. These validation cases are not used in any analysis steps, and are reserved for the subsequent model validation.

5.7.2 Normalization of The Input and Output Data

Commonly, data are normalized for effective training of the developed model. The normalization of the data is the scaling of both the input and output pairs within the range (-1, 1) or to the range (0, 1) depending on the processing function (Hegazy, et al., 1994). In this study, the processing function used to normalize the input and output values within the range (-1, 1) by using the (Max Min processing) method. The Max Min function used to modify the data by the following formula:

$$\text{Scaled value} = \left[\frac{2 \times (\text{original value} - \text{Minimum value})}{(\text{Max value} - \text{Min value})} \right] - 1 \quad \text{Equation 5-3}$$

5.7.3 Neural Network Setup

The architecture of an ANN is a complex, iterative and dynamic process that is require to determine internal structure and rules (i.e., network architecture, learning algorithm, hidden layers' number and neurons numbers for each layer... etc.). An all-inclusive algorithmic method for the configuration of ANN does not exist.

5.7.3.1 Neural Network Architecture

The ANN design procedure is really a decision-making process, which includes determining:

- ANN type
- Number of layers
- Number of neurons

The architecture chosen in this study can be described as the supervised learning ANN multilayer perception (MLP), fully connected, feed-forward neural network (FNN) with backpropation algorithm (further used as ANN). Many studies, have shown that this type of ANNs is capable of subjectively close approximation to any continuous nonlinear mapping type of problems (Abou-Elseoud, 1998). The typical topology of multilayer feed-forward neural networks consisting of input, hidden and output layers (Figure 5-2). The neurons are arranged in layers and interconnect to all neurons in the next layer associated with each connection between this artificial neuron; a weight value (w_i) is defined to represent the connection weight.

$$input = \sum w_i x_i + b \quad \text{Equation 5-4}$$

b is the connection weight associated with a bias node that as an input value of 1

An activation function could be used to produce the value of Y_i of the hidden layers or O_i of the output layer by passing input values through it. Many forms of activation function such as BaisAxon, LinearAxon, ThanhaAxon, Sigmohid Axon, Linear Tanha Axon and Linear Sigmohid Axon are considered to determine the optimum architecture of the ANN model. The most familiar and effective form of sigmoid function, defined as:

$$otuput = \frac{1}{1 + e^{-\alpha(input)}} \quad \text{Equation 5-5}$$

Where:

α is a constant number, which varies between 0.01 and 1.00

For this research, the ANN was designed to consist of one input layer with sixteen input nodes and the output layer have one node. The input factors represent the parameters that influence residential energy consumption.

5.7.3.2 Back-propagation learning rule

There are various alternative paradigms to choose from when applying neural network. Therefore, an important issue to figure out which training strategy to adopt. All the networks will be trained using Levenberg-Marquardt Back-propagation algorithm (LMBP), which is fast and has stable convergence. This algorithm is suitable for training the problems similar to the current study, provides a numerical solution of minimizing a nonlinear function. This algorithm has been shown to perform well in modelling nonlinear functions (Hegazy, et al., 1994). Accordingly, the LMBP rule (supervised training) will be used to construct the current model.

5.7.3.3 Network Size

There is no immediate and exact approach to determine the most proper hidden layers number and Processing Elements (PEs), which are assigned for each layer. Different ANNs with the same training data set can produce similar results. The neural network topology with varied number of processing elements and hidden layers is tested as well, to get the best combination of hidden layers and process elements to solve the given problem with acceptable performance and training times. It is recommended to start experiments with small hidden layer number, and then the number of hidden layers are increased gradually. Some recommendation from previous research work, for example: Hegazy, et al. (1994) heuristically recommended that the hidden neurons number could be usual as one-half of the aggregate input and output neurons. Other recommendations suggest that minimum number of hidden neurons may be as follow (Sodikov, 2005):

$$\text{minimum number of hidden neurons} \geq \frac{p - 1}{n + 2} \quad \text{Equation 5-6}$$

Where:

p is the training examples numbers

n is the network inputs numbers

In this study, an iterative procedure is used of increasing the number of neurons in one and two hidden layers until the network reaches its desired performance.

5.7.3.4 Network Validation

The basic objective in training an ANN model is to minimize the overall error of the network. The typical practice for the validation of ANN model is to assess the

performance measure of network by the selected error metric using both training and testing data sets. The most common types of error are:

- **Mean Absolute Percentage Error**

Mean Absolute Percentage Error (MAPE) is the most common measure forecast error that can be expressed as follows:

$$MAPE = \frac{100}{N \times P} \sum_j^P \sum_i^N \frac{|dy_{ij} - dd_{ij}|}{dd_{ij}} \quad \text{Equation 5-7}$$

Where:

N is the exemplars number in the data set.

P is the output processing elements number.

dy_{ij} de-normalized network output for exemplar i at process element j .

dd_{ij} de-normalized desired output for exemplar i at process element j .

- **The regression correlation coefficient (R^2):**

The regression correlation coefficient (R^2) between a network output and a desired output expresses as follows:

$$R^2 = 1 - \left[\frac{\sum_j^P \sum_{i=1}^N (dy_{ij} - dd_{ij})^2}{\sum_j^P \sum_{i=1}^N dd_{ij}} \right] \quad \text{Equation 5-8}$$

5.7.3.5 Training Function

The NeuroSolutions has a wide variety of training algorithms that apply weights and bias learning rules. The simplest implementation of back-propagation learning

updates the network weights and biases in the direction in which the performance function decreases most rapidly the negative of the gradient, one form of this algorithms can be written as follows:

$$X_{K+1} = X_K + \alpha_K \cdot Y_K \quad \text{Equation 5-9}$$

Where:

X_K is a vector of current weights and biases.

Y_K is the current gradient.

α_K is the learning rate.

For this research work, all of the different training algorithms are experimented with to get the most suitable training function.

5.7.4 Network Training and Testing

In ANN with multilayer feed-forward, the learning procedure refers to the iterative procedure including the training data that is presented to the network; the learning rules are called to modify the connection weights and the network architecture development, such that the knowledge embedded in the training data is properly taken by the weight structure of the network. A back-propagation network is started with initial random weights generated according to training algorithm. The training data presentation to the network as inputs, and network output is calculated. Then, the discrepancy between both network and desired output are evaluated, calculated and used to adjust the weights of network to reduce the difference. As the learning progress, the network's weights are continually adjusted by observing the convergence behaviour of the error until it approaches an acceptable level. Various

back-propagation networks are trained using the 720-training patterns with different number of nodes for each hidden layer by varying the number of hidden layers one and two hidden layers.

5.8 DEVELOPMENT OF A PREDICTION MODEL

One of this study aims is to propose an artificial neural network model that can be used for predicting the energy usage of residential buildings sector in Egypt, which is represent the summation of heating, cooling, lighting and plug-ins loads. Figure 5-4 shows the steps used in order to develop the proposed ANN model within the context of this study.

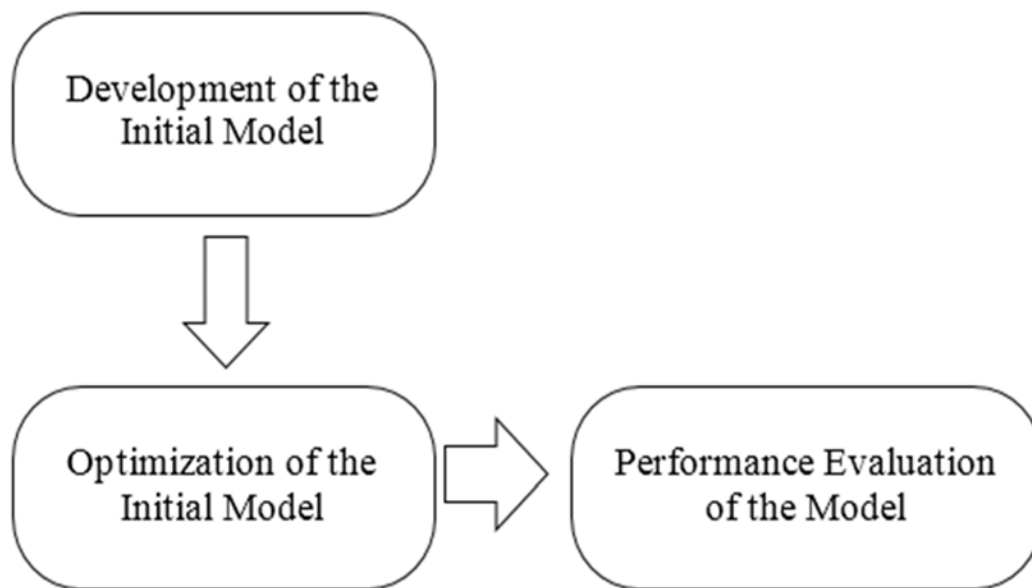

Figure 5-4: Developmnet process of the proposed ANN model

- **First step: Development of an initial model**

The first step is organized to determine the initial model for the activation function, initial number of hidden layers, neurons number in each layer and learning method.

- **Second step: Optimization of the initial model**

The second step is to optimize the initial ANN model through choosing the appropriate activation function, the hidden layers number and the neurons number for each hidden layer to present more accurate and stable results.

- **Third step: Performance evaluation of the model**

The third step is to assess the performance of the ANN model. The accuracy output consequences of the model are analysed by comparing the network output and the desired output.

Table 5-2: The ANN model input and output parameters

Components	Parameters
Input Layer	Number of neurons: 16 neurons Wall Type Slab on Grade Type Roof Type Building Length Building Width Building Height Building Orientation WWR (South) WWR (North) WWR (West) WWR (East) Glass U-value Glass SGHC Glass VT Heating Set Point Cooling Set Point
Output Layer	Number of neurons: 1 neurons Predicted Energy Use Intensity (pEUI)

5.8.1 Development of the Initial Model

The input nodes were composed of the building envelope (walls, roof and slab on grade), building dimension (building length, width and height), building orientation, windows to wall ratio, the properties of glass (U-value, SGHC and VT), heating and cooling set points. Whereas the output node represents the predicted Energy Use Intensity (pEUI) which is the total of cooling, heating, lighting and equipment (plug-ins) electricity consumption (Table 5-2).

Generally, the effective number of neurons is identified by trails, where there is no rule to identify it. Initially, the learning process was started with one hidden layer and with assigned of 33 neurons, using the Equation 5-10 (Moon, et al., 2015)

$$N_h = 2N_i + 1 \quad \text{Equation 5-10}$$

Where:

N_i is the number of inputs ($N_i= 16$)

The initial ANN model is constructed with one input layer representing 16 parameters described before, one hidden layer assigned with 10 neurons and the output layer for one node (pEUI). TanhAxon functions are the transfer functions that used in both input and hidden layers; also the output layer used TanhAxon functions. The back-propagation is the method that been used in ANN training process, associated with Levenberg Marquardt algorithm. Prior to training all inputs and output data were scaled within the range of [-1, 1]. The initial ANN model components and values are summarized in Table 5-3.

Table 5-3: Initial ANN model components and values

Parameter		Component and values
ANN Structure	16-33-1	Input layer: 16 neurons 1st hidden layer: 33 neurons Output layer: 1 neurons
Transfer function	Hidden neuron	TanhAxon
	Output neuron	TanhAxon
Training Method	Goal	0.01 (mean square error)
	Epoch	1,000 times
	Algorithm	Levenberg Marquardt
	Number of data	Training: 720 cases Cross validation: 240 cases Testing: 240 cases

The training is considered to have achieved convergence if both the mean absolute percentage error (MAPE) and regression correlation coefficient (R^2) stabilized over certain iteration. The MAPE and R^2 related to the initial ANN model were calculated for the rescaled prediction and the desired output as 6.4% and 0.971 respectively.

5.8.2 Optimization of the Initial Model

To get stable and more accurate prediction performance from the proposed network, the architecture of initial ANN model and training methods were optimized using a parametrical optimization process based on the method used in the previous researches (Moon, et al., 2015). The transfer function, neurons number and the hidden layer number were sequentially optimized.

- **Optimum Transfer Function**

When the first parameter transfer function was used with a desired variable, the other parameters (i.e., number of neurons and numbers of hidden layer) were fixed as the initial values. After the optimal value of the first parameter was identified, the following parameters (i.e., the hidden layers and the neurons numbers) were optimized, a trial and error procedures is usually used to get the most appropriate network structure (optimum hidden layers umber and the neurons number assigned for each hidden layer). To determine the optimum transfer function is done by changing the transfer function in both hidden and output layers in the initial ANN model 16-33-1 structure. Then, the MAPE for testing process and R^2 for each one changed calculated to measure the ANN model performance and get the optimum transfer function which produce the minimum MAPE and R^2 close to 1 for testing data, the result of these experiments illustrated in Table 5-4.

Table 5-4: Experiments for ANN proposed transfer function

#	Transfer Function		Test Data	
	Hidden Layer	Output Layer	MAPE (%)	R^2
1	TanhAxon	TanhAxon	6.40 %	0.97
2	SigmiodAxon	SigmiodAxon	5.58 %	0.98
3	TanhAxon	LinearTanhAxon	8.00 %	0.96
4	SigmiodAxon	LinearSigmiodA	23.31 %	0.73
5	TanhAxon	LinearSigmiodA	23.45 %	0.84
6	SigmiodAxon	LinearTanhAxon	5.85 %	0.98
7	TanhAxon	SigmiodAxon	7.31 %	0.97
8	SigmiodAxon	TanhAxon	6.42 %	0.97
9	TanhAxon	Linear	7.02 %	0.97
10	SigmiodAxon	Linear	6.07 %	0.97
11	Linear	TanhAxon	10.02 %	0.94
12	Linear	SigmoidAxon	10.01 %	0.94

The MAPE and R^2 related to the best transfer function were calculated as (5.58 %) and 0.98 respectively. Accordingly, the SigmoidAxon function is used for both hidden and output layers to develop the proposed ANN models to predict residential energy consumption.

- **Optimum neural network structure**

Meanwhile there is no direct and exact method to determine the most suitable number of hidden layers and neurons numbers assigned in each hidden layer of a particular problem. For this study, a number of network structures were developed with one hidden layer, which are containing 4, 5, 6, 7, 8, 9, 10, 11, 12, 13, 14, 15, 16, 17, 18, 19, 20, 25 and 33 neurons; and structures using two hidden layers consisting a random number of neurons for each hidden layer.

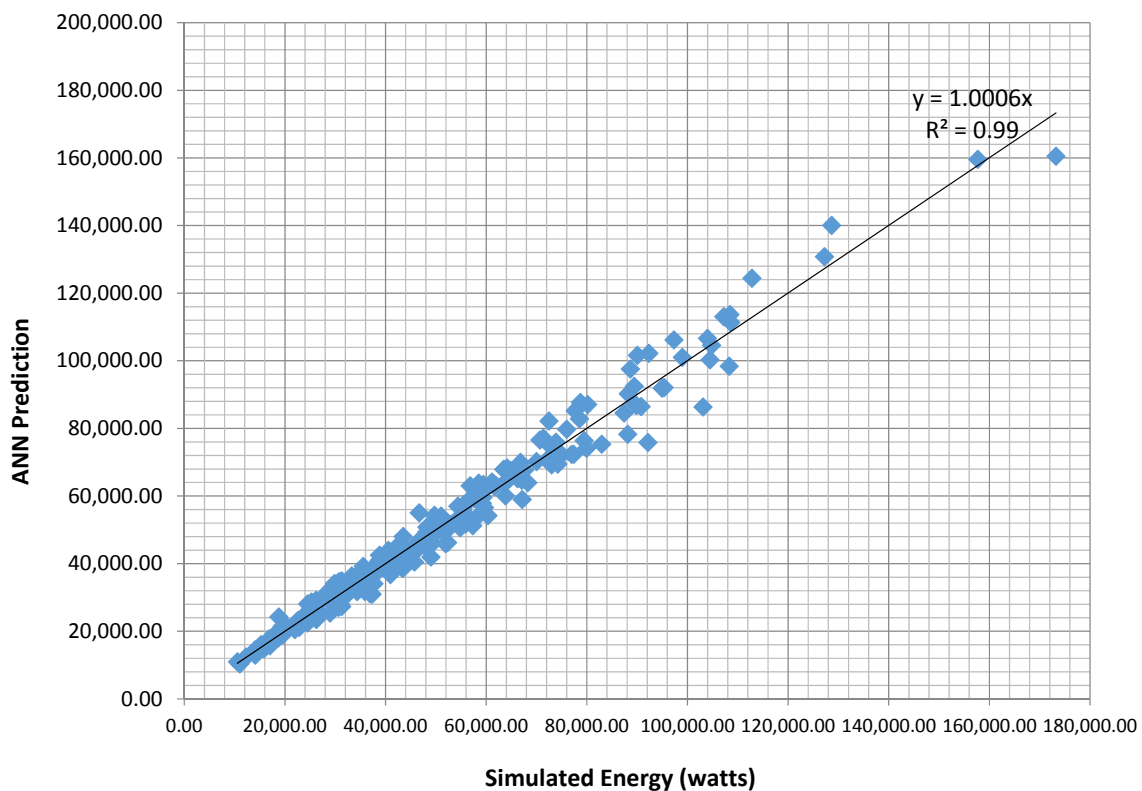

Figure 5-5: Correlation between simulated energy and ANN prediction energy during training process

From Table 5-5, the MAPE and R² related to the best model were calculated as 5.36 % and 0.99 respectively as shown in Figure 5-5. The best ANN model has a 16-10-16-1 architecture, namely, a network having sixteen input variables, ten neurons for first hidden layer and sixteen neurons for the second hidden layer (with SigmoidAxon) and a single (SigmoidAxon) output.

Table 5-5: Experiments to determine the Optimum ANN Architecture

Trail No.	ANN	MAPE	R ²
1	16-4-1	7.01%	0.97
2	16-5-1	6.47%	0.97
3	16-6-1	6.17%	0.97
4	16-7-1	6.28%	0.97
5	16-8-1	6.30%	0.97
6	16-9-1	6.07%	0.94
7	16-10-1	5.58%	0.97
8	16-11-1	6.08%	0.97
9	16-12-1	5.98%	0.97
10	16-13-1	6.32%	0.97
11	16-14-1	5.38%	0.97
12	16-15-1	7.74%	0.94
13	16-16-1	5.47%	0.99
14	16-17-1	5.59%	0.97
15	16-18-1	5.76%	0.98
16	16-20-1	6.22%	0.97
17	16-25-1	6.33%	0.97
18	16-33-1	6.25%	0.97
19	16-10-10-1	5.97%	0.97
20	16-10-12-1	5.71%	0.97
21	16-10-14-1	7.52%	0.96
22	16-10-16-1	7.28%	0.88
23	16-8-8-1	6.59%	0.94
24	16-6-6-1	7.14%	0.96
25	16-6-4-1	8.64%	0.95
26	16-10-8-1	6.87%	0.96
27	16-10-16-1	5.36%	0.99
28	16-10-18-1	7.53%	0.96
29	16-16-16-1	6.06%	0.98
30	16-8-16-1	7.42%	0.96

In summary, the multilayer feed-forward ANNs with (SigmoidAxon) transfer function used because they are very appropriate for modeling of the problems with nonlinear mapping type. Training was set to stop after 1,000 iterations. The MAPE and R^2 statistical measures used to measure the performance of NNs. The final architecture of the ANN model for the energy consumption is illustrated in Figure 5-6.

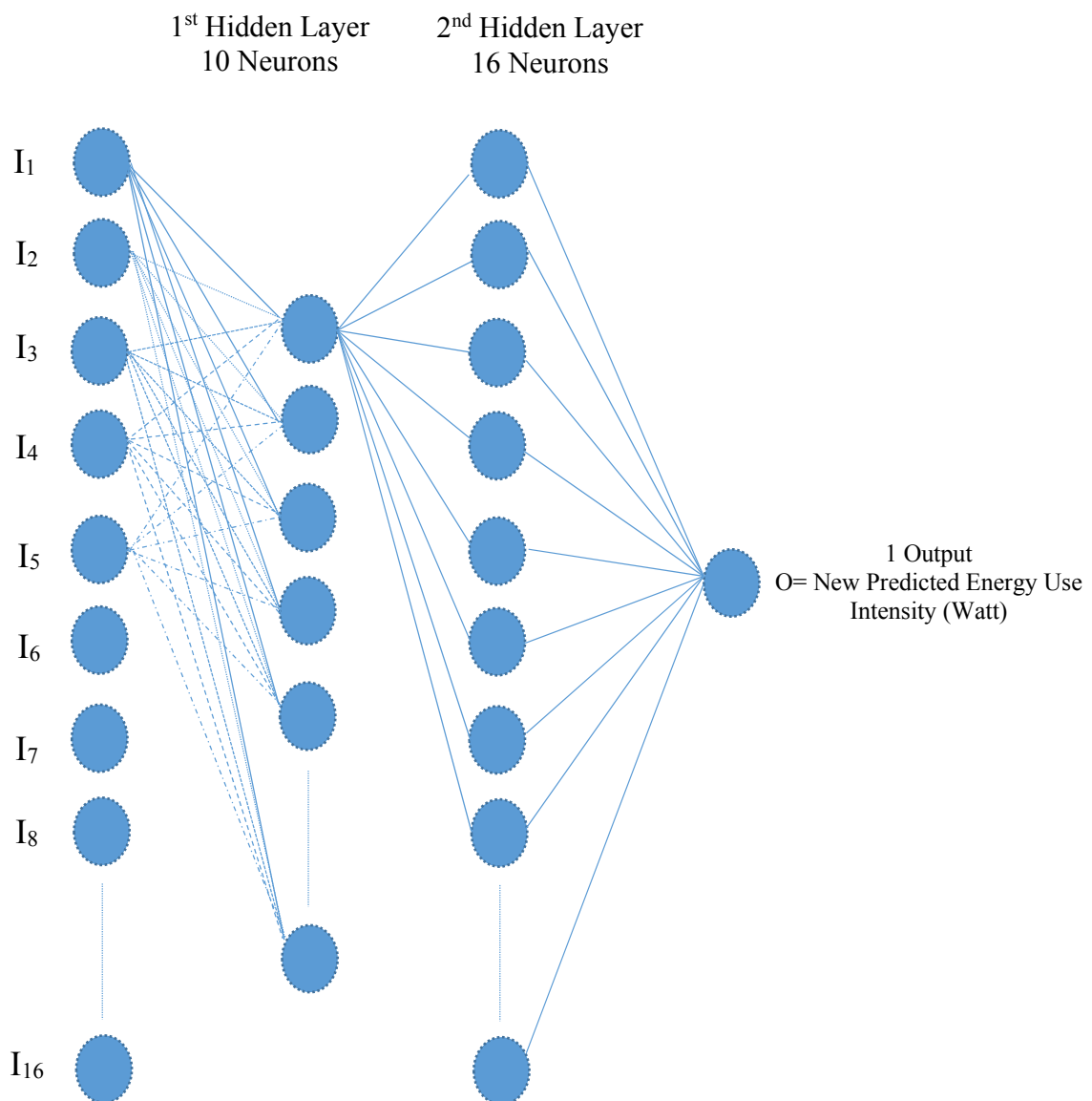

Figure 5-6: Topology of the Optimum ANN Model

- **Performance of the Optimization Model**

The testing model accuracy and validation process is one of the most significant stages in developing an energy prediction model. Moreover, this process states the validation of the ANN model; it includes the developed model testing and evaluation methods. In addition, this process should use selected data from the target population. These data are not used in the training and testing of the model development, but are used specially for validating the developed model. For this study, the validation data is extracted randomly from the overall energy simulations as discussed before. The validation data for this study consists of one hundred sets. The validation data are randomly extracted from the target population of energy simulation models.

The ANN model is used to forecast the energy consumption of residential buildings based on predictions of input validation data to the model. The MAPE is less than 20% which is a typical expected percent error for conceptual prediction model (Peurifoy & Oberlender , 2002). Meanwhile, (Moreno, et al., 2013) drew up a Table 5-6 covering usual values of MAPE for business and industrial data with their interpretation.

Table 5-6: Interpretation of typical MAPE values (Moreno, et al., 2013)

MAPE	Interpretation
< 10	High accurate forecasting
10-20	Good forecasting
20-50	Reasonable forecasting
> 50	Inaccurate forecasting

The results of the validation cases are given for relationship between the predicted values of ANN model and the values already obtained from the simulation process for the energy consumption in Figure 5-7. The calculated MAPE is 5.36 % for validation process, which shows the good performance of the developed ANN model. The validation result proves that the proposed model validity and its ability to predict the energy consumption of residential buildings.

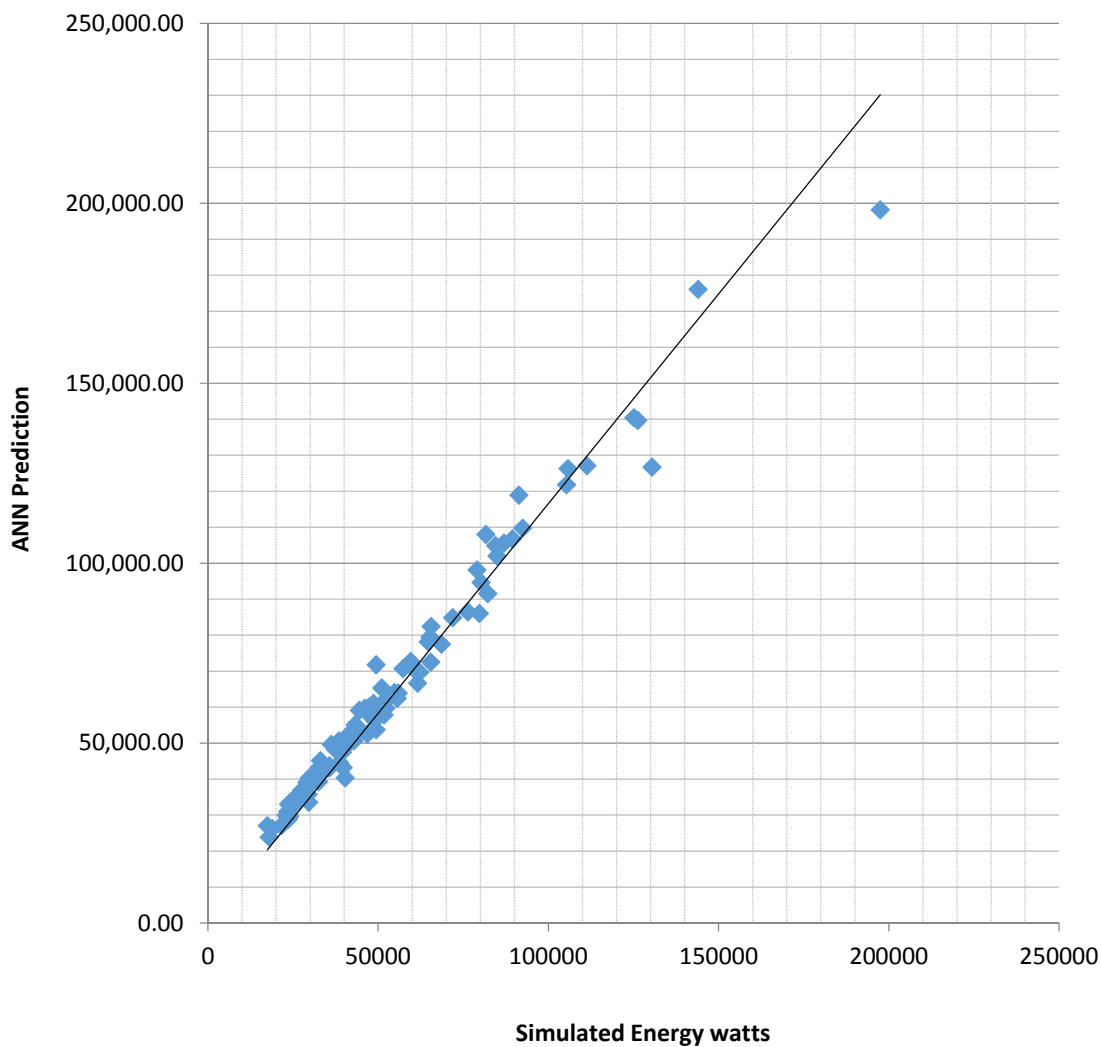

Figure 5-7: Correlation between simulated energy and ANN prediction during testing process

5.9 SENSITIVITY ANALYSIS

In order to assess the predicted ability and validity of the developed model, a sensitivity analysis is performed using the best network selected. Here, sensitivity analysis is conducted in order to determine the most effective parameters on energy consumption of residential buildings in Egypt. This testing process provides a measure of the relative importance among the inputs of the neural model and illustrates how the model outputs varies in response to variation of a given input. The first input is varied between its mean (± 1) as a user-defined number of standard deviations for this study while all other inputs are fixed at their respective means. The network output is computed for a user-defined number of steps above and below the mean.

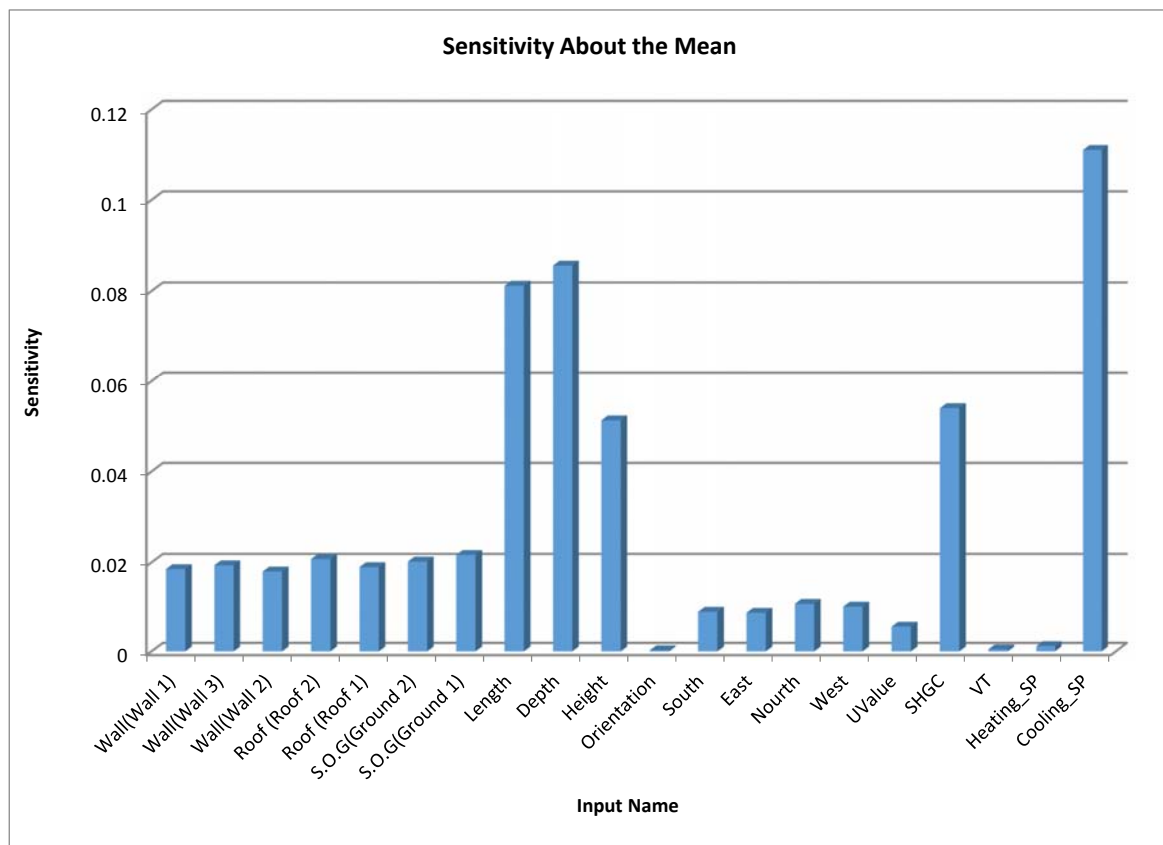

Figure 5-8: Sensitivity analysis of the proposed ANN model

This process is repeated for each input. According to the sensitivity analysis, which is presented in Figure 5-8, although all parameters are effective on ANN output, energy consumption is severely sensitive to cooling set point. It is evident that cooling set point had the highest sensitivity on energy consumption (0.112), followed by building dimensions (0.081) for building length, (0.085) building depth and (0.051) building height, then followed by glass SHGC (0.054). Also, the sensitivity of wall type, roof type and slab on grade which can be expressed as u-value, windows to wall ratio, building orientation, glass u-value, glass TV and heating set point were relatively low. Since residential sector consumes the highest amount of energy for cooling, electrical lighting and electrical equipment form; so, slight changes in cooling set point, glass SHGC and building dimensions can be very effective on energy consumption.

5.10 ANN USER INTERFACE

After learning and testing the ANN model using the developed energy consumption database and the results of sensitivity analysis are logical then the ANN model can be generalized. For this purpose a user-friendly interface is developed (using Excel VB for application) to facilitate designer/modeller to figure out the predicted energy consumption without no experience with modelling and simulation tools. This interface provides the user with many alternative options according to the input parameters, which describe the model. The custom solution wizard is a tool that will take an existing neural network created with NeuroSolutions uses a completed neural network to generate and compile a Dynamic Link Library (DLL) automatically. This DLL can allow incorporating neural network models easily in other NeuroSolutions products and other applications, such as Visual Basic (VB), Visual C++, Microsoft Access and Microsoft Excel. Each shell provides a sample application along with

source code to give the programmer a starting point for integrating the generated DLL into the desired application. The generated neural network DLL provides a simple protocol for assigning the network input and producing the corresponding network output. Figure 5-9 shows the developed interface using VB in Microsoft Excel, and the source code represented in Appendix 2.

Energy Consumption Estimation

Energy Consumption Estimator

Building Envelope

Wall Type

Roof Type

SOG

Glass Properties

Glass U-Value

SHGC

Glass VT

Building Dimensions

Building Length m

Building Depth m

Building Height m

Building Orientation

Orientation

WWR %

South %

East %

Nourth %

West %

Temperature SetPoint

Heating_SP

Cooling_SP

Estimated Energy Consumption

Train

Reset Network Before Training

New **Add** **Estimate** **Exist**

Figure 5-9: VB interface for the energy consumption prediction model

5.11 SUMMARY AND CONCLUSIONS

This chapter presented a comprehensive discussion on the ANN model development. The NeuroSolutions software used to develop the NN model for energy consumption for residential building in Egypt. Accordingly, data for the 1200 cases simulated using EnergyPlus to calculate the energy consumption was used as training, testing and 100 cases for validation. Issues regarding the modelling approach of NNs were discussed, including NN theoretical background, model development and model validation. Three major processes took place for developing and optimizing the ANN model, and testing its prediction performance, respectively. The findings are summarized as follows:

- (1) The initial ANN model for predicting the amount of energy consumption was developed to have sixteen neurons in the input layer represent data regarding building length, building depth, building height, wall type, roof type, slab on grade type, windows to wall ratio percentage for north, south, east and west facades, glass U-value, SHGC and VT, heating set point and cooling set point, one hidden layer with ten neurons and one output neuron represented the energy consumption. In addition, a Levenberg Marquardt was used for the learning methods.
- (2) Through the optimization process using the analysis of the prediction performance of the initial ANN model first round to get the optimum transfer function using several transfer function. The optimum transfer function is SigmoidAxon which represented the lowest MAPE value (5.58 %) and R^2 (0.99). Several network topologies were examined to get the optimum topology of the proposed ANN model. These included networks with one hidden layer containing 4, 5, 6, 7, 8, 9, 10, 11, 12, 13, 14, 15, 16, 17, 18, 19, 20, 25 and 33 neurons. Then, the model was modified to have two hidden

layers with ten and sixteen neurons respectively, with transfer function (SigmoidAxon) for hidden and output layer and networks with two hidden layers containing a random number of neurons in each layer. All networks were trained and tested on 1200 datasets. The performance of the networks on both 720 training datasets, 240 cross validation datasets and 240 testing datasets was calculated and compared using the MAPE and R^2 .

(3) To validate the proposed ANN model, one hundred datasets used to measure the ANN model. The performance tests of the optimized ANN model showed that it presented a lower MPAAE (5.36 %) under the generally accepted levels without improvement for the weights. Thus, the prediction accuracy of the proposed ANN model was proven. This accuracy suggests that the most critical variables controlling the prediction of energy consumption in residential buildings are the sixteen factors used as input data to the ANN model. In addition, sensitivity analysis was carried out in order to determine the importance of the energy measures which were used.

Therefore, the proposed ANN model can be considered a reliable tool for the prediction of energy consumption in residential buildings sector during the conceptual design phase. The finalized neural network can be made available in a generic representation by developing VB application interface to facilitate the data entry for the model and designers who do not have any experience with energy simulation tools.

Chapter 6 SUSTAINABLE BUILDING DESIGN OPTIMIZATION MODEL

6.1 INTRODUCTION

This chapter introduces optimization of sustainable building design considering end-user energy consumption. Then the overall optimization model, which integrates parametric energy simulation, artificial neural network and genetic algorithm, is introduced. The proposed optimization model considers single objective function to obtain the most appropriate design with the goal of achieving, as close as possible, minimum energy consumption for residential building during early design stages. Key design parameters of the building were identified for optimization and feasible ranges for them were searched by the genetic algorithms search technique. Finally, the results of this chapter include the identification of optimum building designs for thermal comfort analysis and optimal energy performance.

6.2 CHARACTERISTICS OF THE OPTIMIZATION TECHNIQUES

Optimization is the procedure of finding the most appropriate outcome between existing different solutions under specified conditions to meet given requirements. The main items required to implement an optimization technique are the objective functions, design variables and constraints. The optimization problems for construction building design are usually considered as unconstrained problems. Whereas, the energy simulation tools could affect in the accuracy for the solver of building simulation which makes the objective function is not necessarily smooth. Otherwise, problems of HVAC sizing and control scheduling optimization are generally constrained with non-linear objective function and may be non-smooth. In this study, the building optimization problems contains design variables that would

be a mix of continuous and discrete types. Moreover, building energy tools are utilized to assess energy consumption and occupants' thermal comfort in residential buildings. The most significant issues of the optimization procedure is to determine an objective function, variables of design and constraints (Kim & Kang, 2016). Therefore, the appropriate optimization algorithm would be selected to this type of problem characteristics.

The selection of the optimization algorithm is subjected to the particularities of the optimization problem. The optimization problem presented in this study has the following characteristics:

- It is a single objective optimization problem.
- The objective function is discontinues.
- It is a hard combinational problem.
- The optimization problem has structured variables (Simulations and ANN model input parameters).

The classical or conventional optimization methods are appropriate to definite types of problems with a number of design parameters. In addition, these methods are subtle to the objective function and the characteristics of design variables: linear, non-linear, continues and discrete. Nowadays, Evolutionary Algorithms (EAs) are implemented overpoweringly in the whole optimization research aspects. Genetic Algorithms (GAs) are considered the most common EAs forms and have several advantages as follows:

- Can deal with discrete variables easily.
- Do not require the objective functions to be continues.
- Efficient to search a large design space.

- Applicable to a wide variety of problems.

GAs have proven to be efficient in solving optimization problems and finding optimal or near optimal solutions (Wang, et al., 2006). In this study, genetic algorithms are used because of these advantages.

6.3 OPTIMIZATION MODEL PARAMETERS

The optimization model in terms of its objective function, constraints and variables is presented as follows:

- **Objective Function**

Since this study aims to support architects and designers to achieve the design with optimum energy performance. The optimization model is carried out through minimize building energy consumption (Equation 6-1). The optimization focuses on the conceptual design phase because of its significance to determine both performance of energy usage and thermal indoor comfort.

$$\text{Min. } \phi \text{ Annual predicted Energy Use Intensity: pEUI} \quad \text{Equation 6-1}$$

In order to evaluate the solutions of design space based on the objective function, all simulation parameters used in optimization model are calculated using the proposed ANN model.

- **Variables**

In the optimization model, a building is limited to a massing box with known building dimensions (length, depth and height). The defined variables with their corresponding names are presented in Table 6-1.

- **Constraints**

Constraints are restrictions on the range of available solutions. Regarding the Egyptian Specifications for Thermal Insulation Work Items (ETSTIW, 2007) and simulation tools default, the constraints of variables are presented in Table 6-1.

Table 6-1: Constraints of variables used for optimization

#	Variables	Lower Bound	Upper Bound
1	Wall Type	0	2
2	SOG Type	0	1
3	Roof Type	0	1
4	Building length (m)	10	30
5	Building depth (m)	10	30
6	Building height (m)	4	15
7	Orientation (°)	0	360
8	South windows to wall ratio (%)	0	80
9	East windows to wall ratio	0	80
10	North windows to wall ratio	0	80
11	West windows to wall ratio	0	80
12	Glass U-value	0	1.2
13	Glass SHGC	0	1
14	Glass VT	0	1
15	Heating Set Point (° C)	18	26
16	Cooling Set Point (° C)	18	28

6.4 OPTIMIZATION MODEL WORKFLOW

One of the study aims is utilizing the genetic algorithms to optimize and select probable design regarding the forecast of building energy usage to obtain the optimal design. Accordingly, the architects or decision makers need to select the appropriate

variables that optimizing their decision. Figure 6-1 summaries the optimization model workflow.

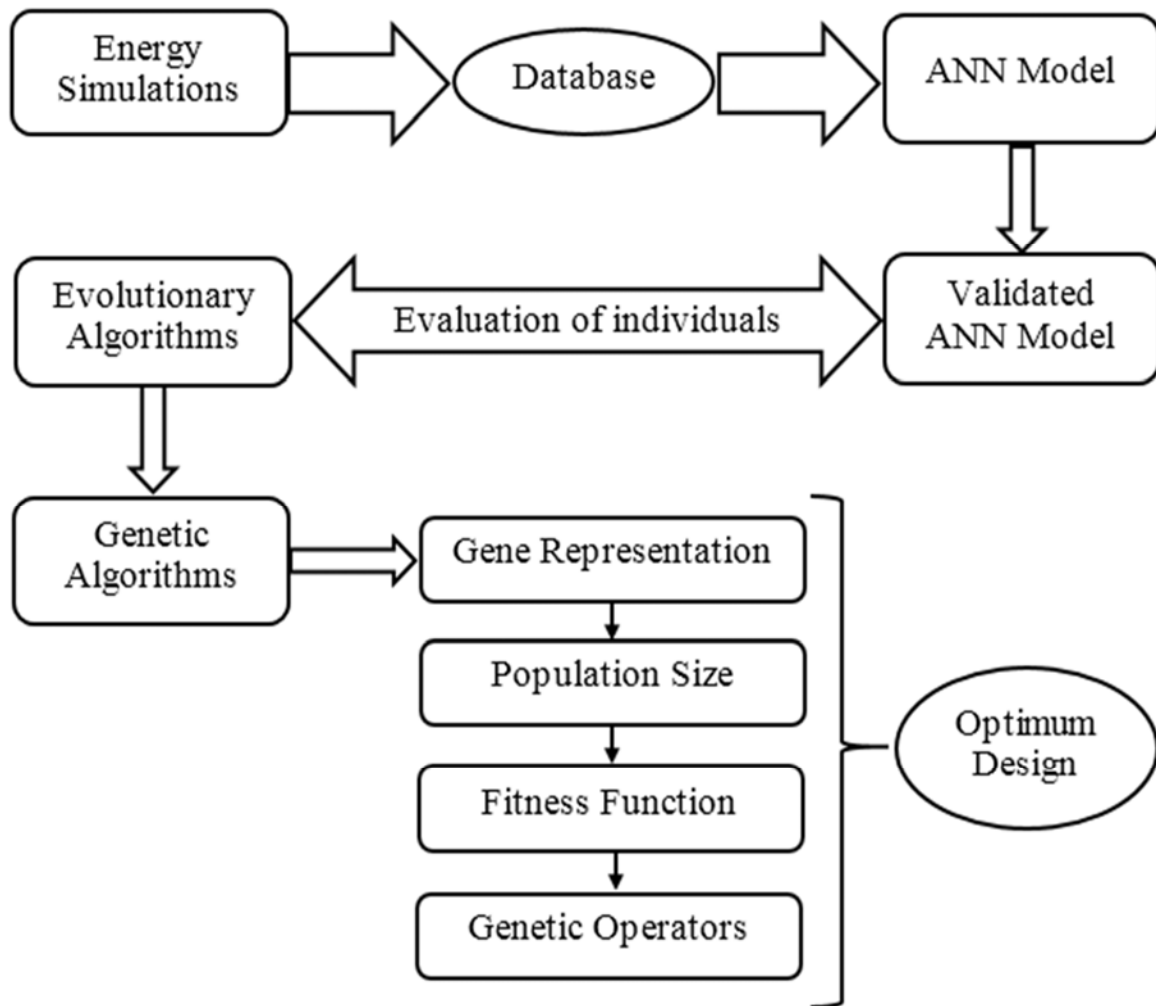

Figure 6-1: The building design optimization workflow

The simulations are performed through Grasshopper and stored in database, which is used to be trained and validated using artificial neural network. The proposed ANN model linked automatically with the GAs to be used in calculating the predicated energy consumption for each individual that represent the solution space without need to call the simulation tools. The core elements of GA for the design optimization model can be illustrated into the following steps:

- Determination of gene representation.
- Determination of initial population size.
- Determination of ranked fitness
- Determination of GA operators and its probabilities.

6.4.1 Gene Representation

In GAs, a coding scheme needed to encode the variables of the problem into a gene. The variables are usually coded into a fixed-length string of binary representation or real values. This study selected real value encoded method. Each solution (alternative design) is represented by a string of elements its length equals the number of variables (16 variables), each element (chromosome) in the solution string represent the variable as shown in Figure 6-2.

	1	2	3	4	5	6	7	16
	Wall Type	SOG Type	Roof Type	Length	Depth	Height	Orientation		Cooling
Gene 1	0	1	0	12	20	12	274	20
Gene 2	1	0	0	16	25	15	54	18
Gene 3	1	1	1	20	28	9	142	22

Figure 6-2: Solutions Representation Optimization Model

6.4.2 Population Size

One of the GAs advantages that it searches many nodes in the search space in parallel. The parallel search size is called population size that is equal to strings (genes) numbers. Population size selection is one of the most significant element of GAs design. Currently, most GAs work with a constant population size (N), which

is determined as a user controlled optimization input parameter. Population size selection needs to be determined experimentally and considered as a problem dependent and has a significant effect on GAs performance and the processing time. Larger population size (hundreds) would explore more the search space and increase the probability of obtaining a global optimum solution; however, it could slow the convergence process and increase processing time. Otherwise, smaller size of population has inaccurate solutions (Alajmi, 2006).

6.4.3 Fitness Function

The fitness function is fundamentally the objective function. The fitness function is used to evaluate the solutions (energy consumption) based on the objective function. The GA process starts with randomized population of solutions. Whereas, the aim of this study is to minimize residential buildings energy consumption, which is being calculated by a simulation then predicted using ANN model, as lower energy consumption, a higher fitness is assigned to the individual. The fitness value of each individual is calculated (Equation 6-2). A good individual is one that scores a high fitness value. In this research, each individual has ranked based on its relative merit, which is calculated as the individual's fitness divided by the total fitness of the whole population (Elbetagi, et al., 2010).

$$fitness (i) = 1/Energy\ consumption \quad \text{Equation 6-2}$$

6.4.4 Genetic Operators

Reproduction

The GAs methodology is to generate the initial population that descended from one generation to the next to search for the best solution. In addition, the generations

number needed to reach convergence are problem dependent that has to determine experimentally. The GA starts with a random initial population. Then algorithm creates a sequence of generations each generation has its new population. Among the operators of GAs, reproduction is the process that used to generate the new population for each generation in GA optimization problem. The following steps implement this operator:

- Scale the raw fitness scores.
- Identify the better string (selection operator) with higher fitness.
- Duplicate the better solution
- Eliminate the worst solution with lower fitness.

The most significant issue for the operator section is the selection pressure; this is a way of ensuring the "survival of the fittest" strings. Many ways are used to implement this operator; proportional selection is the most reproduction operator. The probability of individual being selected is calculated using Equation 6-3.

$$P_{survival}(i) = \frac{fitness(i)}{\sum_{j=1}^{Pop\ Size} fitness(i_j)} \quad \text{Equation 6-3}$$

Each string is allocated to a "slot" of interval (0 to 1) according to the string's $P_{survival}$ value. This kind of selection is performed using roulette wheel mechanism n times. A random number r in the range of (0 to1) is generated randomly each time, where the string with the highest fitness value has a big chance of being selected than other strings.

Crossover

The selection operator does not generate the required new population of solutions for each generation. This operator is used for selecting the better solution then passing it to mating pool and discarding the worst solution. Therefore, crossover is a method used to recombine the selected strings (parent genes) to generate new solutions (offspring/children). Crossover can be implemented in different ways. In this study, each of the two parent genes is randomly selected, the exchange of information between the two genes to create child gene having more than one cross point. This method is known by N-point of crossover operator as presented in Figure 6-3 (Alajmi, 2006).

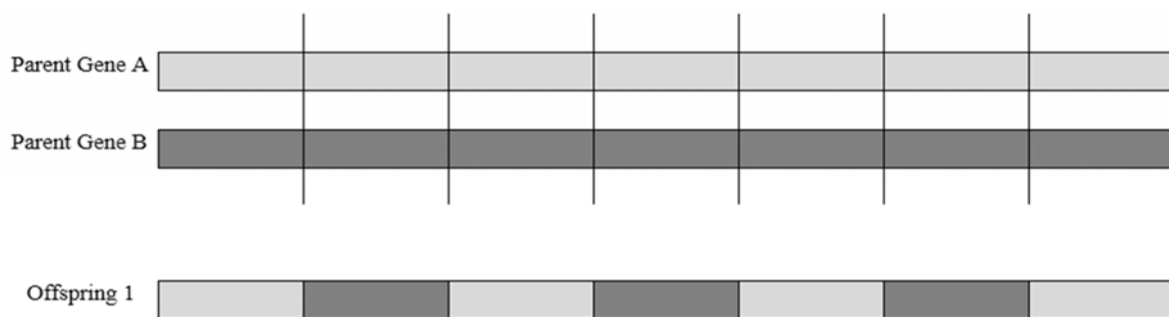

Figure 6-3: Multi-point crossover

However, not all the genes in the population will be subjected to crossover operation; this is controlled by a crossover probability (P_c), which is experimentally determined.

Mutation

The mutation operator is another operation that perturbs the gene values in the confidence of finding a best solution and avoids local optimum solutions by randomly and suddenly altering the genes values. Mutation is opposed to crossover and considers as a secondary GAs operator. Its importance stem from the significant

ensure discovering more into the solution space. Moreover, mutation prevents premature convergence by increasing the population diversity (Elbeltagi, et al., 2005). Like crossover, mutation process is controlled by probability (P_m). For this study, a number " r " is generated randomly in the range of (0 to 1), if r is smaller than (P_m) the mutation take place to generate a new gene randomly.

6.5 OPTIMIZATION MODEL IMPLEMENTATION

As mentioned before, the workings of building design optimization considering energy efficiency require the collaboration of simulation tools, ANN tools to be used for evaluating objective function during optimization process. Before starting the optimization engine, a user usually needs to define optimization problem parameters. Whereas, GAs performance can be sensitive to its control parameters. The change in crossover or mutation probability rate would have an effect on the performance of algorithms. GAs have several parameters that need to be tuned to get the better performance for the optimization model. To identify the proper control parameters values, the GA performance would be assessed for several different sets of parameters. The main control parameters that will applied on the optimization model, are presented in Table 6-2.

Table 6-2: GA control parameters sets

Control Parameter	Values
Population size	[100,150,200]
Crossover probability	[0.8,0.9]
Mutation probability	[0.1,0.2]
No. of Generations	[25,50,100]

The integration between GA and ANN is modeled and coded using Visual Basic (VB). The algorithm code based on the idea of intelligently maximizing call for objective function (call ANN model) before proceeding to optimization process and during the optimization process.

```

Begin
1) Initialize population with N random candidate solutions;
2) Evaluate each candidate (ANN model) by calling DLL file generated by NeuroSolutions;
3) Determine best (minimum energy) and worst (maximum energy) solution;
4) Repeat until termination condition is satisfied;
    Do
        Counter 1 = 0
        Counter 2 = 0
        While Counter 1 ≤ 10
            For i = 1 to number of generations
                P_c=[0.8 OR 0.9]
                Generate random number r between (0, 1)
                If r ≤ P_c
                    Crossover take place (selection of parents)
                    Recombination of pair of parents to produce one offspring
                    New offspring evaluated by calling ANN model
                Else if, mutation take place (generate a new gene randomly), then evaluated
                    The evaluated solution for new offspring is compared to the previous worst;
                    If the new worst is greater than the previous worst, discard
                    Else if, the new worst is smaller than the previous worst, replace
                Next i
                Find the new best s
                If the new best is smaller the previous best
                    Then, replace previous best
                Counter 1 = 0
                Else Counter 1 = Counter 1 + 1
                End IF
                Counter 2 = Counter 2 + 1
                Print the Counter 2 and the best solution
            End
        5) End Do

```

Figure 6-4: Genetic algorithm pseudo code

A user interface application is developed using VB to facilitate the process of data entry. The pseudo code is described in Figure 6-4 and provided in Appendix 3. On starting the proposed model implemented using VB, the user will be asked to enter the following input data that start up both optimization and calling NeuroSolutions as shown in Figure 6-5:

- Building Height
- Building Depth
- Building Height
- Population Size
- Number of Generation/cycle
- Crossover Probability (P_c)

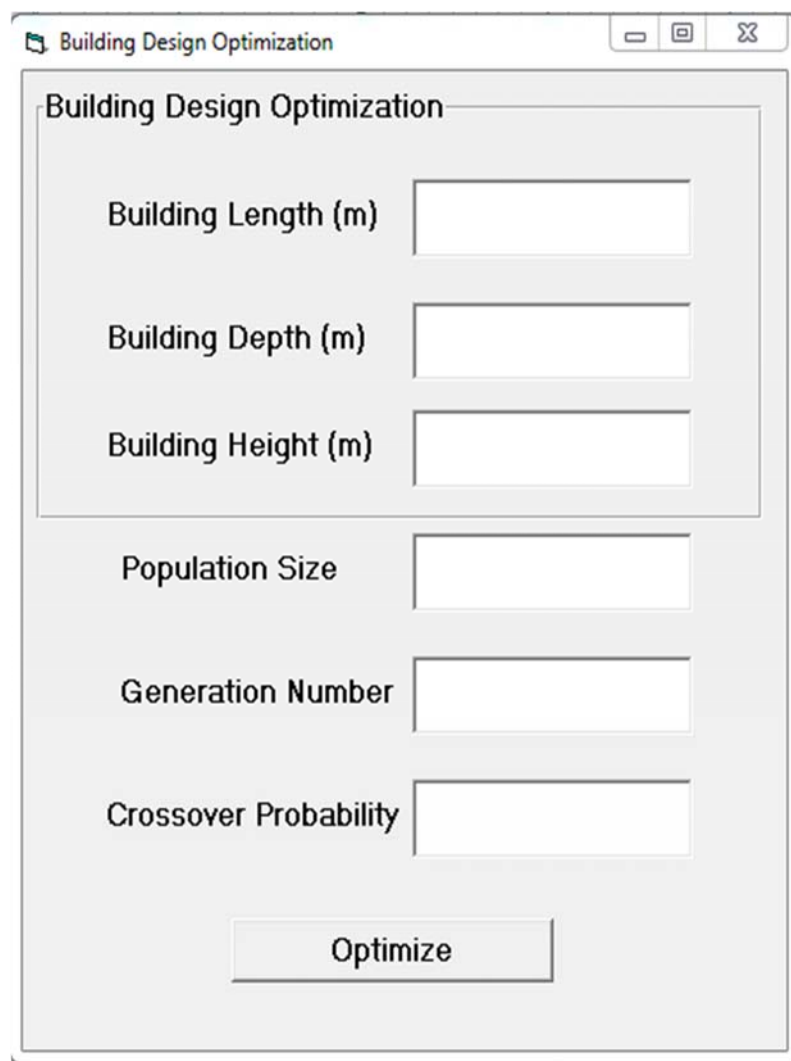

The image shows a screenshot of a Visual Basic application window titled "Building Design Optimization". The window contains a form with the following elements:

- A title bar with the text "Building Design Optimization" and standard window control buttons (minimize, maximize, close).
- A main form area with the title "Building Design Optimization".
- Three input fields for building dimensions: "Building Length (m)", "Building Depth (m)", and "Building Height (m)".
- Three input fields for optimization parameters: "Population Size", "Generation Number", and "Crossover Probability".
- A single "Optimize" button at the bottom center of the form.

Figure 6-5: Developed optimization VB application

In order to identify the most appropriate parameters, different sets of GA control parameters will be generated. This is implemented on an example building to be optimized with different parameters values. A massing box represents a residential building in conceptual design phase with one thermal zone with the following dimensions:

- Building length = 15.0 m
- Building Depth = 20.0 m
- Building height = 12.0 m

In this study, the Cairo Airport weather file is the selected, which represents the surrounding model environmental conditions. The control parameters sets that used for experimentation are presented in Table 6-3.

Table 6-3: Optimization model parameter sets

Population Size	Crossover rate	Generation Number
100	0.7	25
	0.7	50
	0.7	100
	0.9	25
	0.9	50
	0.9	100
150	0.7	25
	0.7	50
	0.7	100
	0.9	25
	0.9	50
	0.9	100
200	0.7	25
	0.7	50
	0.7	100
	0.9	25
	0.9	50
	0.9	100

Each set of parameters presented in Table 6-3 has been experimented. The best solution, which represents the minimum energy consumption for each parameter set, is presented in Table 6-4.

Table 6-4: Values of objective function for best solution

Index	Parameter Sets	Best Solution (watts)
1	[100,0.7,25]	21,044.80
2	[100,0.7,50]	20,105.18
3	[100,0.7,100]	20,325.30
4	[100,0.9,25]	19,827.70
5	[100,0.9,50]	20,249.90
6	[100,0.9,100]	20,192.84
7	[150,0.7,25]	19,832.80
8	[150,0.7,50]	19,962.80
9	[150,0.7,100]	19,767.65
10	[150,0.9,25]	20,334.80
11	[150,0.9,50]	20,047.10
12	[150,0.9,100]	19,708.00
13	[200,0.7,25]	20,489.46
14	[200,0.7,50]	19,913.17
15	[200,0.7,100]	20,080.30
16	[200,0.9,25]	19,888.20
17	[200,0.9,50]	19,600.60
18	[200,0.9,100]	20,106.80

The results represented in Table 6-4 shows that the lowest minimum energy consumption is index no. 17 (19,600.60 watts) to the other parameters sets. The

corresponding optimization variables for the best objective function are presented in Table 6-5.

Table 6-5: The optimum design values

#	Variables	Value
1	Wall Type	0
2	SOG Type	1
3	Roof Type	1
4	Building length (m)	15
5	Building depth (m)	20
6	Building height (m)	12
7	Orientation (°)	42
8	South windows to wall ratio (%)	12 %
9	East windows to wall ratio (%)	11 %
10	North windows to wall ratio (%)	11 %
11	West windows to wall ratio (%)	11 %
12	Glass U-value	0.2
13	Glass SHGC	0.1
14	Glass VT	0.2
15	Heating Set Point (° C)	21
16	Cooling Set Point (° C)	22

In this study, the GA process stops when convergence occurs if the objective does not improve in ten consecutive cycles. Figures 6-6, 6-7, 6-8, 6-9, 6-10 and 6-11 present the experiments of different population size (100, 150 and 200) and number of generation for different evolutionary cycles (25, 50 and 100) with crossover probability of (0.7 and 0.9).

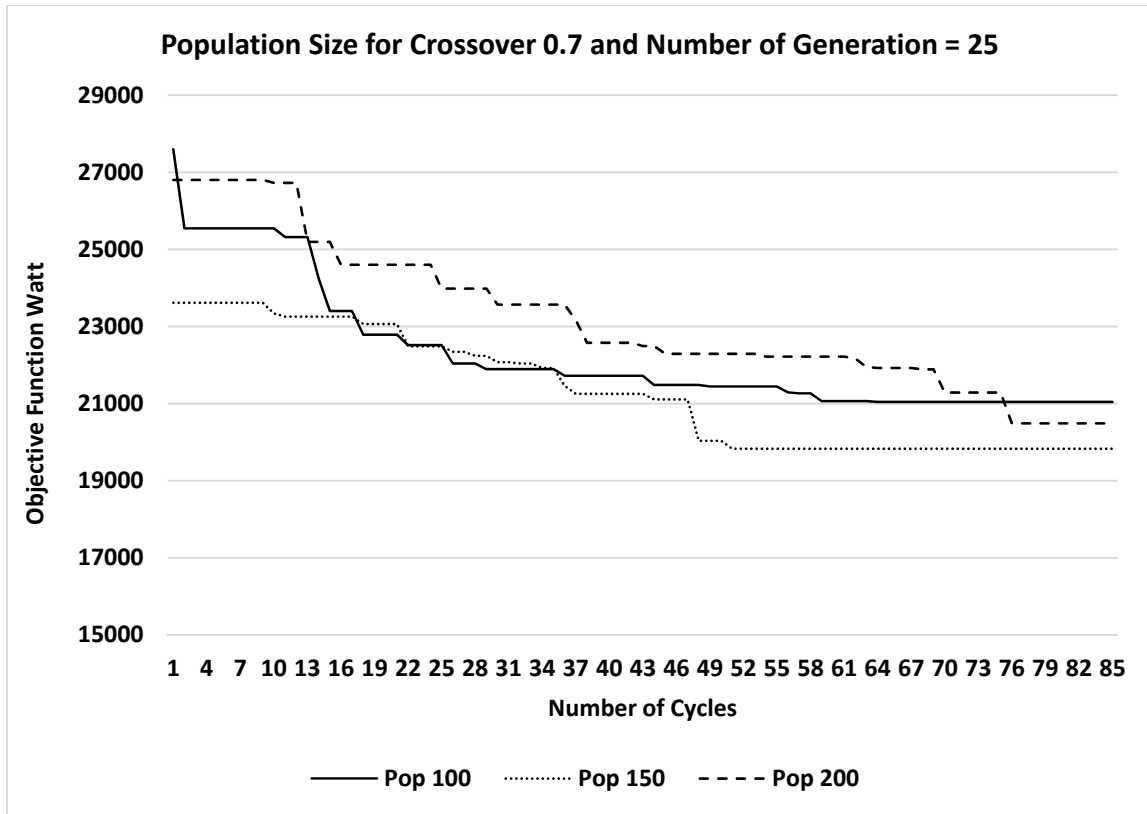

Figure 6-6: Convergence for GA (Crossover 0.7) with 25 generations

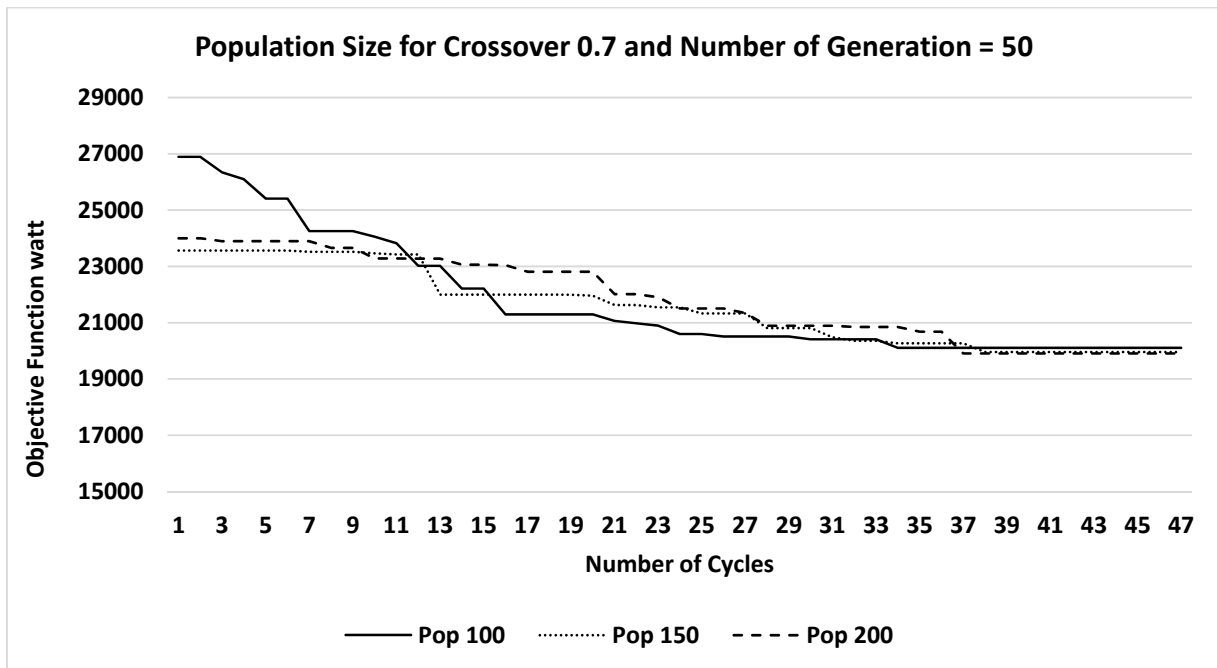

Figure 6-7: Convergence for GA (Crossover 0.7) with 50 generations

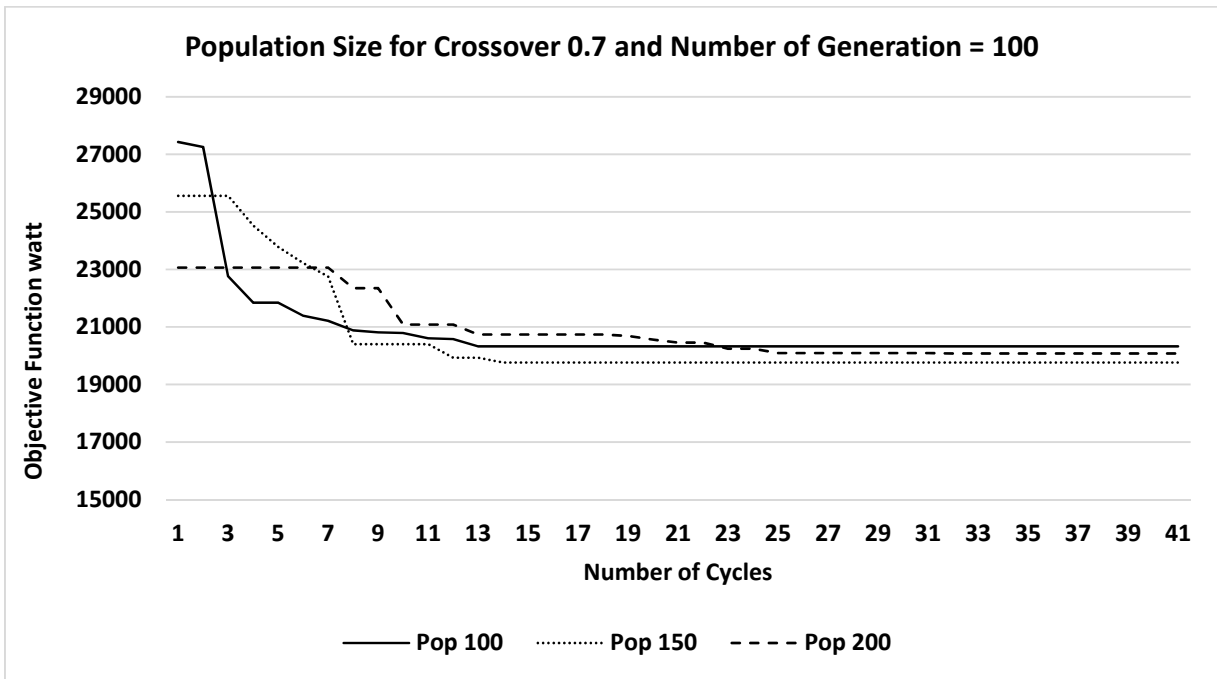

Figure 6-8: Convergence for GA (Crossover 0.7) with 100 generations

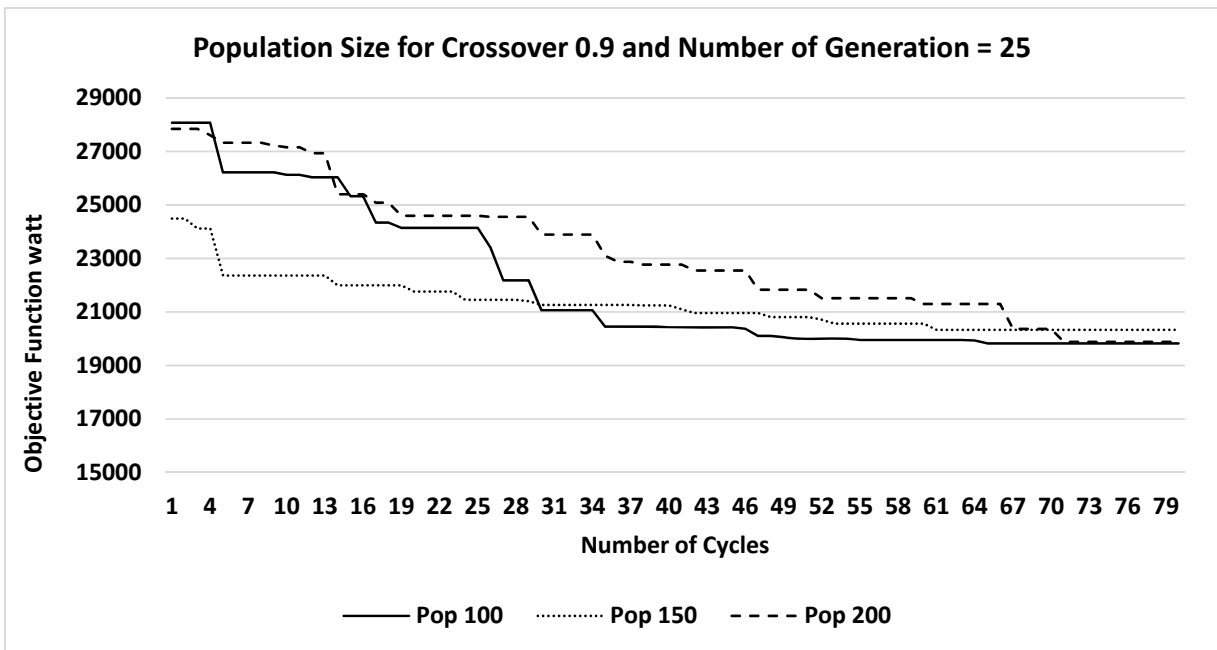

Figure 6-9: Convergence for GA (Crossover 0.9) with 25 generations

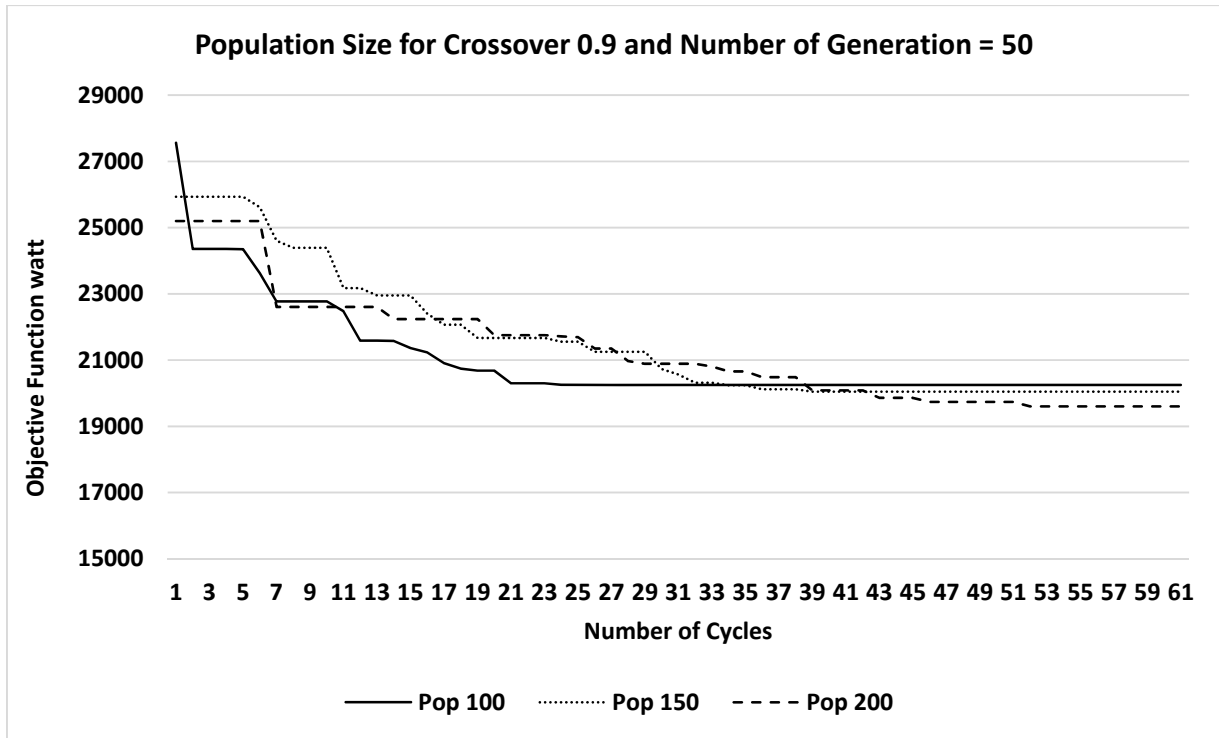

Figure 6-10: Convergence for GA (Crossover 0.9) with 50 generations

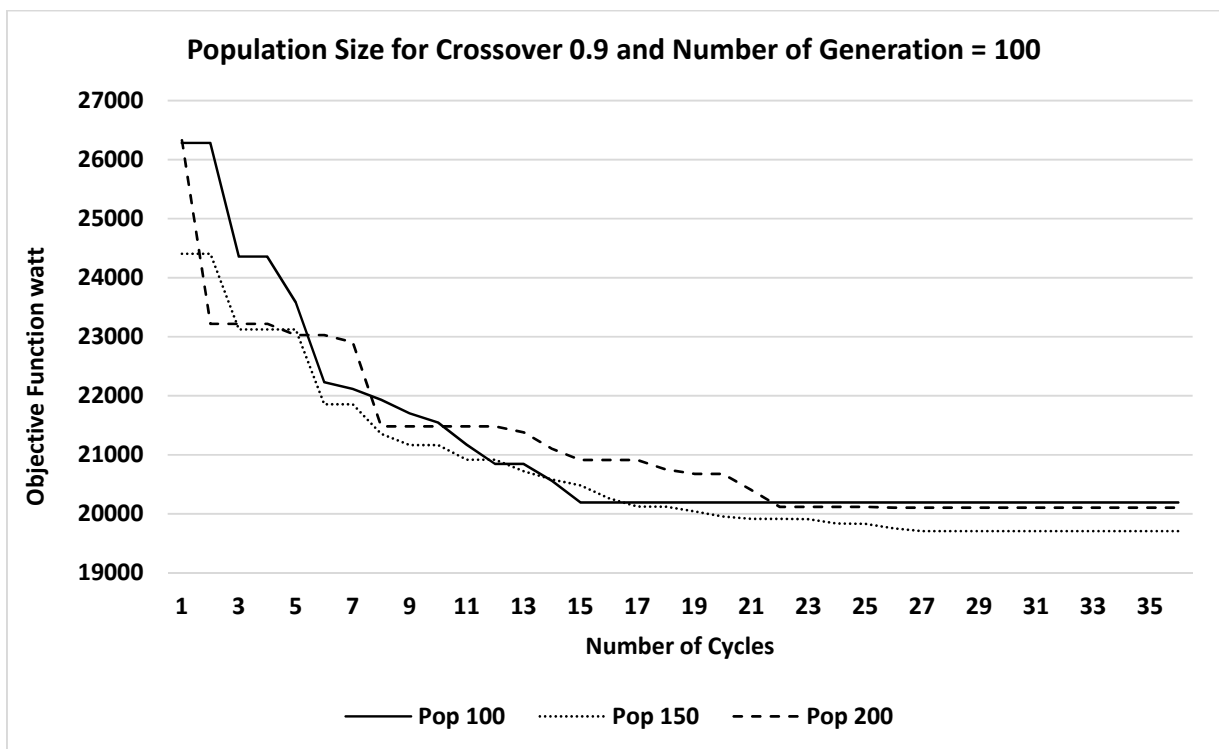

Figure 6-11: Convergence for GA (Crossover 0.9) with 100 generations

6.6 SUMMARY AND CONCLUSIONS

This chapter introduced the final part of the developed framework which is utilized the optimization of building design during conceptual design stage considering energy consumption. The optimization model implemented by develop VB application to facilitate the optimization process, flexible data entry and efficient calculations. The developed model is capable to generate any number of optimizations runs through the application of genetic algorithm integrated with ANN model in order to facilitate the objective function evaluation process with no need to perform any energy simulations. The effectiveness of different GA control parameter sets were examined to finding solutions to a building optimization problem. Sets of parameters were tested and results present that genetic algorithm efficiency is sensitive to most control parameter values population size, probability rate of crossover and number of generation per each cycle. However, the population size was the control parameter that had the most important affect among other control parameters.

Chapter 7 MODEL VALIDATION AND CASE STUDY APPLICATION

7.1 INTRODUCTION

This chapter introduces the application of both ANN and optimization models on a case study. It is divided into four sections. The first section presents the validation of both the simulation and the ANN model. A simplified problem is solved using manual calculations to estimate energy consumption based on the energy analysis of the building in early design stage. The calculation results are compared to the outputs the ANN model using the same input data. The second section illustrates a case study application for testing the optimization model. The third section presents the system validation carried out to determine the model applications' performance.

7.2 MODEL VERIFICATION

Model verification is significant issue to make sure that the applied system works appropriately as supposed. For this study, there is two aspects for validation: the simulation program and ANN model. EnergyPlus has been tested with a broad range of conditions with several test suites including (Rallapalli, 2010):

- International Energy Agency Solar Heating and Cooling Program BESTest (Building Energy Simulation Test) methods
- Analytical Tests
- ANSI/ASHREA standard 14-2004
- EnergyPlus HVAC Component Comparative tests
- EnergyPlus Global Heat Balance tests

EnergyPlus was used to model a range of building specification by the developers So, it can be regard as a heavy tested program formal BESTest validation (Griffith, et al., 2008) efforts were repeated for every release.

In order to validate and verify that the model is predicting energy consumption correctly and its calculations are correct. An example application is solved manually and using the simulation engine with the same framework and principles.

7.2.1 Mathematical Calculations by Hand

The design load calculations are done manually based on the ASHREA design book (Spitler, 2009).

$$Energy\ Demand = \frac{Q_{Total}}{C.O.P} \quad \text{Equation 7-1}$$

Q_{Total} is the total amount of heat gain/ loss for building envelope which is calculated during summer and winter.

$C.O.P$ is the coefficient of performance of Heating/Cooling system.

$$Q_{Total} = Q_{Walls} + Q_{Windows} + Q_{Roof} + Q_{Solar} \quad \text{Equation 7-2}$$

Equation 7-2 is used to calculate the amount of heat gain/loss in watts for building envelope elements.

$$Q_{Walls/Roof} = U * A_{net} * (\Delta T) \quad \text{Equation 7-3}$$

Where

U is the wall/roof system U-value

A_{net} is the element cross section net area (m²)

ΔT is the indoor and outdoor temperature difference

$$Q_{Windows} = U * A_{Window} * (\Delta T) \quad \text{Equation 7-4}$$

Where

U is the glass U-value

A_{net} is the window area (m²)

ΔT is the indoor and outdoor temperature difference

$$Q_{Solar} = A_{Glass} * SHGC * SG * CLF \quad \text{Equation 7-5}$$

Where

Q_{Solar} is heat gain amount due to solar radiation in watts

A_{Glass} is net glass area (m²)

$SHGF$ is glass solar heat gain factor

SG is the shading coefficient ($SG = 1.0$ No Shading)

CLF is the cooling load factor

- **Building Information**

- Location (New Cairo)
- Building Dimensions (15 × 20 × 9.0 m)
- WWR % for North façade: 30%
- WWR % for South façade: 10%
- WWR % for East façade: 20%
- WWR % for West façade: 20%
- Heating Set Point: 21°C
- Cooling Set Point: 21°C
- Outdoor average temperature in Summer 37.10°C (Assad, 2011)

- Outdoor average temperature in Winter 9.32°C (Assad, 2011)

• **Walls Thermal Calculations**

Exterior walls: wall type 1 (5 layers)

$$R_{Total} = R_1 + R_2 + R_3 + R_4 + R_5$$

$$R_i = \frac{1}{K_i} * t_i$$

#	Layer	Thickness (m)	Conductivity [w/m-K]	R_i
1	Plaster	0.005	0.016	$R_1 = \frac{1}{0.016} (0.005) = 0.312$
2	Cement Mortar	0.025	1.0	$R_2 = \frac{1}{1.0} (0.025) = 0.025$
3	Red Brick	0.12	0.60	$R_3 = \frac{1}{0.6} (0.12) = 0.20$
4	Cement Mortar	0.025	1.0	$R_4 = \frac{1}{0.016} (0.005) = 0.312$
5	Plaster	0.005	0.016	$R_5 = \frac{1}{1.0} (0.025) = 0.025$
R_{Total}				0.87

$$U = \frac{1}{R_{total}} = \frac{1}{0.87}$$

$$Q_{\text{wall-summer}} = U\Delta T = \frac{(37.10-21)}{0.87} = 18.5 A_{\text{wall-net}}$$

$$Q_{\text{wall-winter}} = U\Delta T = \frac{(21 - 9.32)}{0.87} = 13.4 A_{\text{wall-net}}$$

Façade	A_{wall} (m²)	A_{window} (m²)	A_{wall net} (m²)	Q_{summer} (A_{net}UΔT)	Q_{winter} (A_{net}UΔT)
North	15*9 = 135	40.5	94.5	1748.25	1266.3
South	15*9 = 135	13.5	121.5	1998	1447.2
East	20*9 = 180	36.0	144.0	2997	2170.8
West	20*9 = 180	36.0	144.0	2997	2170.8
Total				9740.25 watts	7055.1 watts

- **Windows Thermal Calculations**

Windows type: 6.0 mm single glass. Table 7-1 summarized the glass properties (Assad, 2011)

- U-value = 5.56

$$Q_{Summer} = 5.56 (31.10 - 21) A_{Window} = 56.2 A_{Window}$$

$$Q_{Winter} = 5.56 (21 - 9.32) A_{Window} = 64.9 A_{Window}$$

Façade	A_{Window} (m²)	Q_{Summer}	Q_{Winter}
North	40.5	2114.1	2628.45
South	13.5	704.7	876.15
East	36.0	1879.2	2336.4
West	36.0	1879.2	2336.4
Total		6577.2 (watts)	8177.4 (watts)

Heat Gain due to Solar Radiation (Q_{Solar})

Glass U-value = 1.0 Btu/h-ft²-°F (5.67 w/m²k)

SHGC = 1.0

VT = 0.7

Table 7-1 Solved example glass properties

Façade	SHGF summer	SC summer	CLF summer	SHGF winter	SC winter	CLF winter
South	152.5	1.0	0.83	127	1	0.83
East	681.05	1.0	0.8	599.78	1	0.8
North	118.4	1.0	0.91	83.81	1	0.91
West	681.05	1.0	0.8	599.78	1	0.8

Façade	A_{Glass} (m²)	Q_{Solar} (Summer)	Q_{Solar} (Winter)
North	32.4	3490.906	2471.054
South	10.8	1367.01	1138.428
East	28.8	15691.39	13818.93
West	28.8	15691.39	13818.93
Total		36240.7 (watts)	31247.34 (watts)

• **Roof Thermal Calculations**

Roof type 1 is made of one cement tiles layer, one cement mortar layer, one clean sand layer, one insulation bitumen layer and one reinforcement concrete.

#	Layer	Thickness	Conductivity	R_i
1	Cement Tiles	0.01	1.50	0.01
2	Cement Mortar	0.02	1.0	0.02
3	Sand	0.05	0.33	0.15
4	Bitumen Damp Insulation	0.02	0.15	0.13
5	Reinforce Concrete	0.15	1.44	0.10
R_{Total}				0.42

$$Q_{Roof} = UA(\Delta T)$$

$$U = \frac{1}{R} = \frac{1}{0.42} = 2.4$$

$$Q_{Roof}(Summer) = 2.4 * (15 * 20) * (31.10 - 21) = 7272 \text{ watts}$$

$$Q_{Roof}(Winter) = 2.4 * (15 * 20) * (21 - 9.32) = 8409.6 \text{ watts}$$

- **Energy Demand**

$$Q_{Total}(Summer) = 9740.25 + 6577.2 + 36240.7 + 7272.0 = 59830.15 \text{ watts}$$

$$Q_{Total}(Winter) = 7055.1 + 8177.4 + 31247.34 + 8409.6 = 54889.4 \text{ watts}$$

The cooling type is split units which used with cooling COP = 3.0 (standard efficiency) and heating C.O.P = 4.0 for winter (Assad, 2011).

$$Energy_{Demand} = \frac{59830.15}{3} + \frac{54889.4}{4} = 33665.7 \text{ watts}$$

$$Total \text{ enegy} = Eenergy_{Demand} + Lighting_{Deamnd} + Equipment_{Demand}$$

$$Lighting_{Deamnd} = Lighting_{Load} * A = 7.3 * (15 * 20) = 2190.0 \text{ watts}$$

$$Equipment_{Demand} = Equipment_{Load} * A = 7.0 * (15 * 20) = 2100.0 \text{ watts}$$

$$Total \text{ energy} = 33665.7 + 2190 + 2100 = 37955.7 \text{ watts}$$

7.2.2 Thermal Energy Simulation by EnergyPlus

The same input data that used to solve the example application is used to be model and simulated using Rhino/Grasshopper and EnergyPlus. Figure 7-1 presents the thermal simulation input and output data. The simulation output was 55312.74 watts; the solved example result is differing than the simulation output. Simulation result is considered as the best energy consumption, which is used the simulation engine (EnergyPlus) with high accuracy rather than manual calculations.

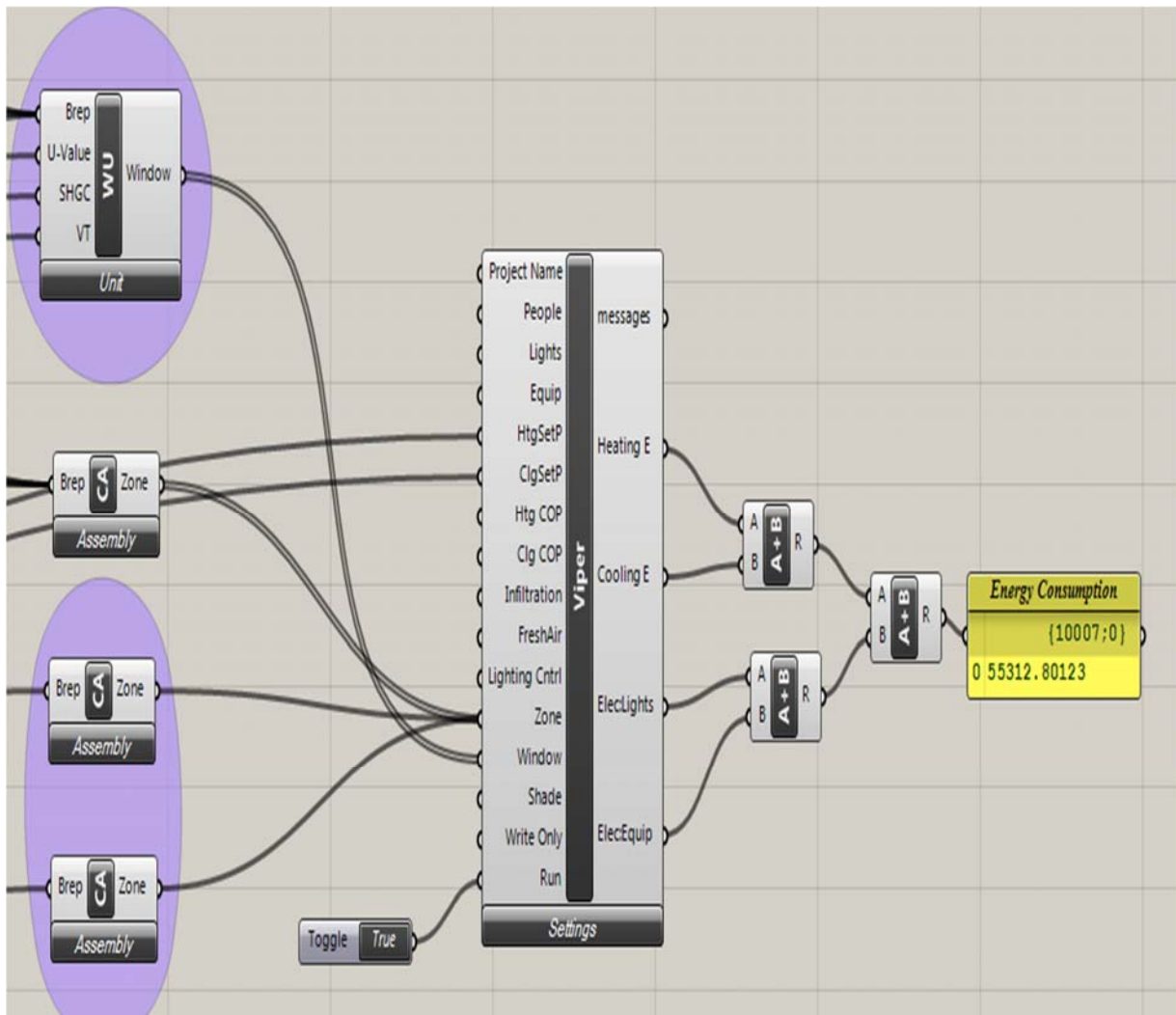

Figure 7-1: Grasshopper definition for solved example output

7.2.3 Using the ANN to Solve Example Application

The input data for the example application were used in the developed ANN model to predict the energy consumption. The output was 52106 watts (Figure 7-2).

The thermal energy analysis using EnergyPlus is more value that is accurate. SO, this value is used as a reference to estimate the percentage error for both ANN model and mathematical calculations.

$$\% \text{ for mathematical calculations} = \frac{55312.74 - 37955.7}{55312.74} = 31.4 \%$$

$$\% \text{ for ANN model} = \frac{55312.74 - 52106}{55312.74} = 5.79 \%$$

The prediction accuracy of the proposed ANN model was proven in Chapter 5 with MAPE (5.36 %) under the generally accepted levels that is very close to the percentage error (5.79 %) between the simulation and predicted energy consumption with the same framework and principles. The calculated energy consumption using simulation engine is considered the reference to measure the accuracy of both manual and ANN model. The percentage error for mathematical and ANN model outputs reference to the simulation engine are 31.4% and 5.79% respectively. In order to use manual calculations to predict energy performance assumptions and simplifications need to be made. These assumptions will lower the accuracy of the results. The time required to calculate accurate results manually can be large and any errors in the process lead to more time. Where, manual calculations cannot optimize the design. This increases the difficulty and time taken to rework the original design.

Energy Consumption Estimation

Energy Consumption Estimator

Building Envelope		Glass Properties	
Wall Type	0	Glass U-Value	1
Roof Type	0	SHGC	1
SOG	0	Glass VT	.7
Building Dimensions		WWR %	
Building Length	15 m	South	0.316227766016 %
Building Depth	20 m	East	0.447213595499 %
Building Height	9 m	Nourth	0.547722557505 %
Building Orientation		West	0.447213595499 %
Orientation			
0			
Temperature SetPoint			
Heating_SP	21	Cooling_SP	21
Estimated Energy Consumption		52106	
Train		Not tested.	
<input checked="" type="checkbox"/> Reset Network Before Training		<input type="button" value="New"/> <input type="button" value="Add"/> <input type="button" value="Estimate"/> <input type="button" value="Exist"/>	

Figure 7-2: ANN model application for solved example

7.3 CASE STUDY APPLICATIONS

The proposed model was applied to a case study representing actual construction project was executed in Egypt. It is required to exploring the trade-off between the energy consumption with occupant thermal comfort for a typical residential building. A single-family residential building construction in new districts of Egypt, which is located in New Cairo (Figure 7-3).



Figure 7-3: Isometric of residential building case study

Table 7-2 Characteristics of the case study building

Location	New Cairo
Floor area	252m ²
Building Length	14 m
Building Depth	18 m
Floor-to-floor height	3 m
Number of floors	3
Exterior wall area	380 m ²
Orientation	45°
North façade (WWR)	20 %
South façade (WWR)	10 %
East façade (WWR)	15 %
West façade (WWR)	15 %
Wall Type	Wall type 1
Roof Type	Roof type 1
SOG Type	SOG type 1
Glass Type	Single glass 6mm
Glass U-value	5.67 w/m ² k
Glass SHGC	1.0
Glass VT	0.7
Heating Set point	22°C
Cooling Set Point	22°C

At the project design stage, the design team wanted to determine the most appropriate design that achieves minimum energy consumption among alternative designs. Table 7-2 summarizes the set of information that represent the basic characteristics of the building envelope and thermal energy simulation parameters. These characteristics are the baseline design options for the building. For example, the building orientation of the baseline is 45°. There are many possible combinations of building design options. Where the large number of combinations requires important computing time, moreover the interoperability between modeling and simulation tools. The design team has difficulties in trade-off between design parameters to generate group of design options, then simulate each design option to calculate the energy usage. Design team suggested the alternative design options associated for each energy parameter (orientation, glass type and wall type) with the baseline that highlighted in bold as listed in Table 7-3. In addition, the building dimensions, windows area and the other parameters are all constant values, in order to reduce the computing time that is a significant barrier to determine the best design. In this project, (5 * 3 * 2 = 30) different designs were performed.

Table 7-3: Alternative designs options

Energy Parameter	Options	No. of Options
Orientation	0°, 45° , 90°, 135°, 180°	5
Wall Type	Wall type 1 Wall type 2 Wall type 3	3
Glass Type	Single glass 6mm Double glass 6/6/6 mm	2

The simulation results for each design option are listed in Table 7-4. The minimum energy consumption was 31918.71 watts associated to the design option number

D06, where the energy consumption for the baseline design option was 35623.07 watts. The percentage of energy saving was 10.4 % due to changing the building orientation, wall type and roof type. The developed optimization model is introduced to the design team for the evaluation of the level of alternatives that generated without no need to both simulation and optimization experience. The model was applied to the project as shown in Figure 7-4, which is an extract of the interface window of the optimization model. After entering the user information in the optimization model, optimization is performed to reach the design that achieves minimum energy consumption. Table 7-5 introduces the optimum design using optimization set of parameters: population size, crossover and number of generation are 200, 0.9 and 50 respectively.

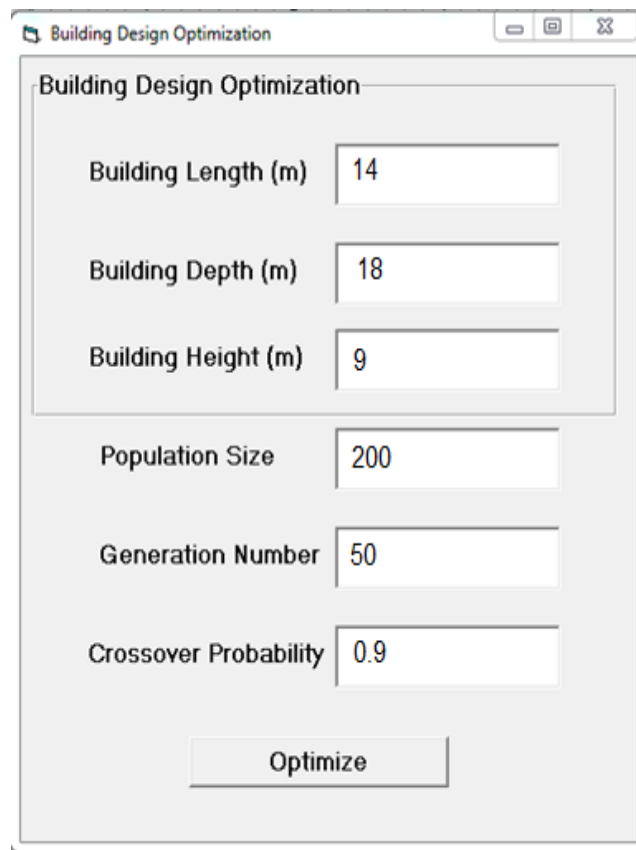

Figure 7-4: Case study optimization process

Table 7-4: Design options simulation results using EnergyPlus

#	Orientation	Wall Type	Roof Type	Energy (watts)
D 01	0	1	1	34990.92
D 02	0	1	2	32797.32
D 03	0	2	1	34405.34
D 04	0	2	2	32191.14
D 05	0	3	1	32201.09
D 06	0	3	2	31918.71
D 07 (Baseline)	45	1	1	35623.07
D 08	45	1	2	33727.34
D 09	45	2	1	35043.57
D 10	45	2	2	32665.92
D 11	45	3	1	32673.52
D 12	45	3	2	32394.41
D 13	90	1	1	35301.86
D 14	90	1	2	32857.03
D 15	90	2	1	34767.12
D 16	90	2	2	32289.26
D 17	90	3	1	32317.47
D 18	90	3	2	32041.29
D 19	135	1	1	36228.04
D 20	135	1	2	33685.93
D 21	135	2	1	35687.84
D 22	135	2	2	33109.39
D 23	135	3	1	33116.34
D 24	135	3	2	32850.34
D 25	180	1	1	35964.55
D 26	180	1	2	33431.17
D 27	180	2	1	35440.06
D 28	180	2	2	32866.23
D 29	180	3	1	32878.87
D 30	180	3	2	32612.72

Table 7-5: The optimum design for case study

#	Variables	Value
1	Wall Type	2
2	SOG Type	1
3	Roof Type	1
4	Orientation (°)	48
5	South windows to wall ratio (%)	16 %
6	East windows to wall ratio (%)	13 %
7	North windows to wall ratio (%)	18 %
8	West windows to wall ratio (%)	11 %
9	Glass U-value	0.6
10	SHGC	0.5
11	VT	0.5
12	Cooling set point	22
13	Heating set point	20
Energy Consumption		26421.12 watts

As a result, the most appropriate design that achieves minimum energy usage includes the increase of the envelope walls and roof thickness. In addition, WWR has great influence where the best ratio is place to North and South avoiding the huge heat gained from West and East facades. The percentage of energy saving is (25.8 %) when using the developed optimization algorithms. Project design team valued this outcome because it allows designer to select the best design timely, accurately and overcome the interoperability issue.

7.4 MODEL VALIDATION

After testing the developed model through its application on the case study, it was important to ensure that the model is useful as per the experts' opinion. Therefore, to

investigate the performance of the ANN and optimization model and its credibility, a questionnaire form was prepared and distributed to ten design professionals. Professionals' experiences were chosen to range from 10 – 15 years in Egypt. Interviews were made with the professionals prior filling up the questionnaire form to exemplify the model description, functions and main features. The professionals were asked to use the model application and then fill the questionnaire based on six criteria as follows:

- Access to interface
- Interface look
- Relevance of inputs
- Validity of outputs
- Usefulness
- Overall performance

Each of those six criteria was to be evaluated based on five grades: excellent, very good, good, fair, or poor. Those five grades were given in a linguistic qualitative term to facilitate the evaluation of each criterion. The professionals were also asked to add any additional recommendations or comments which they see essential to enhance and improve the system. The questionnaire form is presented in Appendix 4. After gathering the results from all of the ten professionals, it was supposed to come out with one significant average result representing the model performance. Therefore, as a beginning, the five grades were converted from qualitative term into quantitative value as shown in Table 7-6. Hence, the quantitative value given by each user for each criterion is as shown in Table 7-7.

Table 7-6: Conversion of grades

Qualitative term	Quantitative value
Excellent	5
Very good	4
Good	3
Fair	2
Poor	1

Table 7-7: Results of system validation

	1	2	3	4	5	6	7	8	9	10	Total	Average
Access to interface	4	4	5	5	5	5	4	3	3	4	42	4.2
Interface look	4	4	4	5	4	4	5	4	4	5	43	4.3
Relevance of inputs	5	5	4	4	5	3	3	4	5	5	43	4.3
Validity output	4	5	4	4	5	4	4	4	4	5	43	4.3
Usefulness	5	5	4	4	4	4	5	5	5	5	46	4.6
Overall performance	4	4	3	3	5	5	4	3	4	4	39	3.9
Overall average												4.2

The set of values given by each expert for each criterion was summed up and divided by the number of users, i.e. 10, as shown in Table 7-7. Finally, the average score for each criterion was summed up and divided by the number of criteria, i.e. 6, in order to get the overall average representing the model's performance. This means - based on the experts' evaluation – that the model's performance is (4.2) out of (5.0), i.e. 84 %, which can be considered acceptable.

7.5 SUMMARY AND CONCLUSIONS

This chapter is divided into three main sections; first section illustrates the validation of thermal simulation engine (EnergyPlus) and its capabilities to be used in the

context of this study. Where, EnergyPlus provides the highest level of simulation accuracy and enables automated sizing of many component-specific parameters. Then, the developed ANN model verification is carried out by using solved example. The thermal simulation analysis was performed by EnergyPlus with the same input data, the output value is considered the reference value of energy consumption due to the accuracy of the simulation engine. Finally, the ANN model application is used to predict the energy consumption using same input data. The percentage of error between the reference value and energy consumption from both mathematical calculations and ANN model are 31.4 % and 5.79 % respectively. Section two, discussed a case study application using the proposed optimization model. Since the main concept is obtaining the most, appropriate design that achieves the minimum energy usage. It worked on finding the best available design for the considered building orientation, envelope (walls, roof and glass types), windows to wall ratios and other parameters that affects the thermal simulation analysis (heating and cooling set points). The design team trade-off between 30 alternative designs that include the baseline design. Then the optimization model is used to get the best design. The percentage of energy saving between baseline design and both design team trial and optimization model are 10.4 % and 25.8 % respectively, which means increasing the energy saving percentage due to the optimization process. Through the third section, the validation of both ANN and optimization models took place to determine the models' performance. The performance is estimated based on the evaluation of design professionals through a distributed questionnaire and interviews, it was found that the model's performance was (4.2) out of (5.0), i.e. 84 %.

Chapter 8 CONCLUSIONS AND FUTURE RECOMMENDATIONS

8.1 INTRODUCTION

This chapter summarizes the main conclusions of developing an approach for selecting the most appropriate envelope design that achieves the minimum energy consumption for a residential building during the early design stage. In addition, suggestions about possible areas of future research are presented. It is divided into two main sections: section one discusses the main considerations obtained from this study; and section two lists the possible areas for future work.

8.2 CONCLUSIONS

Improvement in building design and thermal analysis performance have significant role in the pursuit of a sustainable building designs. Numerous decisions that highly affect building performance are made at the early design stage when many competitive alternatives are generated and compared. Therefore, there is a need for a reliable energy simulation model to predict buildings energy consumption to develop suitable tools that can assist decision makers and designers in finding an optimal or near design effectively. The optimization model is such a tool developed in this study to carry out simulation-based optimization throughout artificial neural network for sustainable building design. The conclusions obtained from this study can be summarized as follows:

1. The optimization scope focuses on the building envelope and simulation setting parameters that has significant impacts on the building performance considering energy consumption.

2. The most significant decisions that affect both energy consumption and thermal analysis are made during the conceptual design phase. In this phase, it basically determines the building dimensions, envelope, thermal zones and construction material assemblies.
3. The parametric analysis is employed to model, simulate and evaluate energy usage and occupants' thermal performance. A mass building model was generated and converted into thermal analytical automatically.
4. The developed simulation workflow in one platform (Rhino/Grasshopper) presenting automated and simplified approach to simulate and analysis building energy performance with a more timely, accurate and efficient process.
5. The developed simulation workflow integrates parametric modelling and energy simulation engine in one platform to overcome the problem of interoperability.
6. A generic model with parametric analysis of different parameters affecting energy consumption are considered (building dimensions, orientation, windows-to-wall ratio (WWR), wall type, roof type, SOG type, Glass U-Value, SGHC, VT, heating and cooling set points).
7. Several random values for each parameter are generated, and then these parameters are analysed through a multiple simulation process to generate energy consumption database for more 12,000 simulations.
8. A new strategy for multidimensional data that allow designer to figure out energy usage without reference to simulation and energy tools.
9. Parallel Coordinate Plot is one of visualization techniques that is used to develop and support a web-based application, which facilitates the

visualization process as well as the accessibility to the generated database of energy consumption.

10. The developed web-based application can be used for any visualization multidimensional data by uploading (.csv) file, needed to be visualized.
11. The developed database is used for learning and training an Artificial Neural Network model with friendly user interface to predict the energy usage.
12. The ANN is able to accurately predict the studied metrics with a mean percentage average error of 5.36% under the generally accepted levels.
13. Sensitivity analysis was performed to show the effect of energy efficiency measures on the energy consumption in residential buildings. It is evident that cooling set point had the highest sensitivity on energy consumption, followed by building dimensions, then glass SHGC.
14. To optimize the building design, an automatic optimization method is needed. Genetic algorithms are employed as the optimization technique.
15. Genetic algorithms parameters that compose different set of population size, the probability of crossover and the rate of mutation were experimented with in order to measure the GA performance.
16. The control parameters of GA were evaluated, the results showed the parameters that had the most important effect was the population size, since the large population size gave better results than the smallest population size.
17. The ANN model verification was carried out to determine the model's performance based on solved example with the following methods; manual calculations, thermal analysis using EnergyPlus and the developed ANN model.

18. The optimization model is implemented in actual case study, which allowed project design team to select the most appropriate design which achieves minimum energy consumption.
19. The overall model validation was carried out to determine its performance based on the professionals' evaluation throughout a questionnaire survey and interviews with the experts. It was found that the performance of the model was rated by (4.2) out of (5.0), i.e. 82%.

8.3 RECOMMENDATIONS FOR FUTURE WORK

This study opens the door to extra areas of research and considerations. This research could be extended to consider the following:

1. Increase sustainable considerations that would be assessed as carbon footprint, embodied energy and recycling in order to add a great value to work and raised environmental awareness.
2. The mechanical systems could be incorporated in the simulation process where integrating building envelope with the mechanical systems which may affect the performance of building significantly.
3. This thesis has focused on the building envelope for one thermal zone (mass building). However, multi-zones, multi-story analysis, interior walls and doors can be considered showing their effect on building performance.
4. Thermal comfort is definitely a factor that will influence building design. It may be of first priority in some cases, especially for residential buildings during the subsequent conceptual design stage.
5. Many aspects such as daylight could be considered in the simulation program. For example, this research regards lighting load as a constant value. This can be changed if day lighting is considered.

6. Multiple attribute decision-making factors (Life Cycle Costing) could be implemented and integrated with thermal analysis, in order to enhance both economic and environmental performance issues using multi-objective optimization techniques.

REFERENCES

1. AbdelAzim, A. I., Ibrahim, A. M. & Aboul-Zahab, E. M., 2016. Development of an energy efficiency rating system for existing buildings using Analytic Hierarchy Process – The case of Egypt. *Renewable and Sustainable Energy Reviews*, Volume 71, pp. 414-425.
2. Abou-Elseoud, M. K., 1998. Artificial neural network-based physiological models: Prediction of energy cost in manual lifting activities. Doctoral Dissertation, University of Miami, Ohio.
3. Abu Bakar, N. N., Hassan, M.Y., Abdullah, H., Rahman, H.A., Abdullah, M.P., Hussin, F. and Bandi, M., 2015. Energy efficiency index as an indicator for measuring building energy performance: A review. *Renewable and Sustainable Energy Reviews*, Volume 44, pp. 1-11.
4. Abu Jamous, H., 2013. Parametric cost estimation of road projects using artificial neural networks. Master's Thesis, The Islamic University, Gaza.
5. AIA, 2012. An Architect's Guide to Integrating Energy Modeling in the Design Process, USA: Energy Modeling Working Group and Building Green, www.aia.org/aiaucmp/groups/aia/documents/pdf [Accessed 2015].
6. Aibinu, A. A., Dassanayake, D., Chan, T.K. & Thangaraj, R., 2015. Cost estimation for electric light and power elements during building design: A neural network approach. *Engineering, Construction and Architectural Management*, Volume 22(2), pp. 190 - 213.
7. Alajmi, A. F., 2006. Efficient optimisation of building design using a genetic algorithm. Doctoral Dissertation, Loughborough University, London.
8. Assad, M., 2011. Towards promoting sustainable construction in Egypt: a life-cycle cost approach. Master's Thesis, American University in Cairo, Cairo.

9. Attia, S. & De Herde, A., 2011. Early design simulation tools for net zero energy buildings: a comparison of ten tools. Sydney, Australia, International Building Performance Simulation Association 2011, Sydney.
10. Attia, S., Gratia, E., De Herde, A. & Hensen, J. L., 2012. Simulation-based decision support tool for early stages of zero-energy building design. *Energy and buildings*, Volume 49, pp. 2-15.
11. Attia, S. & Wanas, O., 2012. The Database of Egyptian Building Envelopes (DEBE): A Database for Building Energy Simulations. *IBPSA-USA Journal* , Volume 5(1), pp. 96-103.
12. Autodesk, 2015. Autodesk Education Community. [Online]
Available at: <http://sustainabilityworkshop.autodesk.com/buildings/glazing-properties> [Accessed 2015].
13. Bagnasco, A., Siri, A., Aleo, G., Rocco, G. and Sasso, L., 2015. Applying artificial neural networks to predict communication risks in the emergency department. *Journal of Advanced Nursing*, Volume 71(10), pp. 2293–2304.
14. Berisha, X. & Dragusha, B., 2015. The influence of the outside temperature during the design of a heating system. *International Conference & Workshop REMOO-2015*, Budva.
15. Biswas, M. R., Robinson, M. D. & Fumo, N., 2016. Prediction of residential building energy consumption: A neural network approach. *Energy*, Volume 117, pp. 84-92.
16. BLAST, 2003. BLAST Homepage. [Online]
Available at: <http://www.bso.uiuc.edu/BLAST/index.html> [Accessed 2015].

17. Boussabaine, A. H., 1996. The use of artificial neural networks in construction management: a review. *Construction Management and Economics*, Volume 14(5), pp. 427-436.
18. Braasch, E., 2016. The feasibility of Building Performance Sketching'within the building design process. Master's Thesis, Victoria University of Wellington, Wellington.
19. Bunz, K. R., Henze, G. . P., E., P. & Tiller, D. K., 2006. Survey of sustainable building design practices in North America, Europe, and Asia. *Journal of Architectural Engineering*, Volume 12(1), pp. 33-62.
20. Caldas, L. G. & Norford, L. K., 2002. A design optimization tool based on a genetic algorithm. *Automation in Construction*, Volume 11, pp. 173-184.
21. Caldas, L. G. & Norford, L. K., 2003. Genetic algorithms for optimization of building envelopes and the design and control of HVAC systems. *Journal of solar energy engineering* , Volume 125(3), pp. 343-351.
22. CASBEE, 2016. CASBEE. [Online] Available at: <http://www.ibec.or.jp/CASBEE/english/index.htm> [Accessed 2016].
23. Cavieres, A., Gentry, R. & Al-Haddad, T., 2011. Knowledge-based parametric tools for concrete masonry walls: Conceptual design and preliminary structural analysis. *Automation in Construction*, Volume 20, p. 716–728.
24. Chen, X., Yang, H. & Wang, Y., 2017. Parametric study of passive design strategies for high-rise residential buildings in hot and humid climates: miscellaneous impact factors. *Renewable and Sustainable Energy Reviews*, Volume 69, pp. 442-460.

25. Churchland, S. . P. & Sejnowski, T. J., 1992. *The Computational Brain*. MIT Press, London.
26. Coley, D. A. & Schukat, S., 2002. Low-energy design: combining computer-based optimisation and human judgement. *Building and Environment*, Volume 37(12), p. 1241–1247.
27. Corrado, V., Mechri, H. E. & Fabrizio, E., 2007. Building energy performance assessment through simplified models: application of the ISO 13790 quasi-steady state method. In *Proceedings of building simulation*, pp. 79-86, Beijing.
28. Crawley, D.B., Lawrie, L.K., Winkelmann, F.C., Buhl, W.F., Huang, Y.J., Pedersen, C.O., Strand, R.K., Liesen, R.J., Fisher, D.E., Witte, M.J. & Glazer, J., 2001. EnergyPlus: creating a new-generation building energy simulation program. *Energy and buildings*, Volume 33(4), pp. 319-331.
29. Crawley, D. B. et al., 2004. EnergyPlus: New, Capable and Linked. *Journal of Architectural and Planning Research*, Volume 21(4), pp. 292-302.
30. Crawley, D. B., Pedersen, C. O., Lawrie, L. K. & Winkelmann, F. C., 2000. EnergyPlus: energy simulation program. *ASHRAE journal*, Volume 42(4), pp. 49-56.
31. Degelman, L. . O. & Soebarto, V. . I., 1996. *Whole building energy performance-simulation and prediction for retrofits*, Texas A&M University, Texas.
32. DOE, U., 2007. U.S. DOE. [Online]
Available at: <http://www.energytoolsdirectory.gov> [Accessed 2015].
33. Edsall, R. M., 2003. The parallel coordinate plot in action: design and use for geographic visualization. *Computational Statistics & Data Analysis*, Volume 43(4), pp. 605-619.

34. EGBC, 2015. Egyptian Green Building Council. [Online]
Available at: <http://egypt-gbc.org/> [Accessed 2016].
35. Ekici, B. B. & Aksoy, U. T., 2009. Prediction of building energy consumption by using artificial neural networks. *Advances in Engineering Software*, Volume 40, pp. 356–362.
36. Elbeltagi, E., Hegazy, T. & Grierson, D., 2005. Comparison among five evolutionary-based optimization algorithms. *Advanced Engineering Informatics*, Volume 19, pp. 43–53.
37. Elbetagi, E., Hegazy, T. & Grierson, D., 2010. A new evolutionary strategy for Pareto multi-objective optimization. *Proceedings of the Seventh International Conference on Engineering Computational Technology*, Stirlingshire, Scotland .
38. Elharidi, A. M., Tuohy, P. . G., Teamah, M. . A. & Hanafy, A. A., 2017. Energy and indoor environmental performance of typical Egyptian offices: survey, baseline model and uncertainties. *Energy and Buildings*, Volume 135, pp. 367-384.
39. ElKington, J., 1998. Partnerships from cannibals with forks: The triple bottom line of 21st-century business. *Environmental Quality Management*, Volume 8(1), pp. 37-51.
40. Eltaweel, A. & Su, Y., 2017. Controlling venetian blinds based on parametric design; via implementing Grasshopper's plugins: A case study of an office building in Cairo. *Energy and Buildings*, Volume 139, pp. 31-43.
41. ETSTIW, 2007. The Egyptian Specifications for Thermal Insulation Work Items. Cairo, Egypt: Ministry of Housing, 176/1998.

42. Farzanaa, S., Liu, M., Baldwin, A. & Hossain, M. U., 2014. Multi-model prediction and simulation of residential building energy in urban areas of Chongqing, South West China. *Energy and Buildings*, Volume 81, pp. 161-169.
43. FEMP, 2015. Federal Energy Management Program - Department of Energy. [Online] Available at: <https://energy.gov/eere/femp/federal-energy-management-program> [Accessed 2015].
44. Ganjehkaviri, A., Jaafar, M. M., Hosseini, S. & Barzegaravval, H., 2017. Genetic algorithm for optimization of energy systems: Solution uniqueness, accuracy, Pareto convergence and dimension reduction. *Energy*, Volume 119, pp. 167-177.
45. González, J. & Fiorito, F., 2015. Daylight design of office buildings: optimization of external solar shadings by using combined simulation methods. *buildings*, Volume 5(2), pp. 560-580.
46. Gowri, K., 1990. Knowledge-based system approach to building envelope design. Doctoral Dissertation, Concordia University, Montreal.
47. Griffith, B. et al., 2008. Methodology for modeling building energy performance across the commercial sector, s.l.: National Renewable Energy Laboratory, Golden, CO, Technical Report NREL/TP-550-41956, March, www.nrel.gov/docs/fy08osti/41956.pdf. [Accessed 2014]
48. Günaydın, H. M. & Dogan, S. Z., 2004. A neural network approach for early cost estimation of structural systems of buildings. *International Journal of Project Management*, Volume 22(7), pp. 595-602.
49. Habibi, S., 2017. Micro-climatization and real-time digitalization effects on energy efficiency based on user behavior. *Building and Environment*, Volume 114, pp. 410-428.

50. Hanna, G. B., 2013. Green energy and green buildings in Egypt. *International Journal of Engineering Research and Applications*, Volume 3(4), pp. 466-470.
51. Haykin, S., 1998. *Neural Networks: A Comprehensive Foundation*. [book] Prentice Hall, New Jersey, USA.
52. HBRC, 2005. *Egyptian code for energy efficiency improvement in buildings*. Housing and Building Research Center, Cairo.
53. He, B., Han, Y., Zhao, L. & Shen, L., 2017. A Comparison Study on the Green Building Performance Assessment Tools for Promoting Sustainable Construction. Springer Singapore, In *Proceedings of the 20th International Symposium on Advancement of Construction Management and Real Estate*, pp. 1169-1184.
54. Hegazy, T., Fazio, P. & Moselhi, O., 1994. Developing Practical Neural Network Application Using Backpropagation. *Microcomputers in Civil Engineering*, Volume 9(2), pp. 145-159.
55. Heidegger, V., 2013. *Operational energy optimizing tool for conceptual facade design*. Delft, Netherlands: Master's Thesis, Delft University of Technology, Delft, Netherlands.
56. Hensen, J. L. M. & Lamberts, R., 2011. *Building performance simulation for design and operation*. [book] Taylor & Francis Group, UK.
57. HKHA, 2005. *Annual Report 2004/2005*, Hong Kong: HKSARG.
58. Ihm, P. & Krarti, M., 2012. Design optimization of energy efficient residential buildings in Tunisia. *Building and Environment*, Volume 58, pp. 81-90.

59. ISO, 2007. Thermal performance of buildings calculation of energy use for space heating and cooling. Geneva: ISO/FDIS 13790.
60. Jakubiec, J. A. & Reinhart, C. F., 2011. DIVA 2.0: Integrating daylight and thermal simulations using Rhinoceros 3D, Daysim and EnergyPlus. In Proceedings of building simulation, Volume 20(11), pp. 2202-2209.
61. Kim, H. Y. & Kang, H. J., 2016. A Study on Development of a Cost Optimal and Energy Saving Building Model: Focused on Industrial Building. *energies*, Volume 9(3), p. 181.
62. LEED, 2016. LEED. [Online] Available at: <http://www.usgbc.org/leed> [Accessed 2016].
63. Lee, K. S., Han, K. J. & Lee, J. W., 2016. Feasibility study on parametric optimization of daylighting in building shading design. *Sustainability*, Volume 8(12), pp. 1220-1236.
64. Lin, B., Yu, Q., Li, Z. & Zhou, X., 2013. Research on parametric design method for energy efficiency of green building in architectural scheme phase. *Frontiers of Architectural Research*, Volume 2(1), pp. 11-22.
65. Lugmaier, A., 2000. Optimisation of Energy Efficiency Methods in Buildings regarding Life Cycle Costs. Master's Thesis, Technical University of Denmark, Denmark.
66. Maile, T., Fischer, M. & Bazjanac, V., 2007. Building energy performance simulation tools-a life-cycle and interoperable perspective. Center for Integrated Facility Engineering (CIFE) Working Paper, Volume 107, pp. 1-49.
67. Melo, A. P., Lamberts, R., Cóstola, D. & Hensen, J. . L., 2013. Development of a method to predict building energy consumption through an artificial neural

- network approach. In Proceedings of the 13th Conference of the International Building Performance Simulation Association, Chambéry, France.
- 68.MNRE, 2015. Ministry of New and Renewable Energy. [Online]
Available at: <http://www.mnre.gov.in/> [Accessed 2015].
- 69.Moon, J. W., Jung , S. K., Lee, Y. O. & Choi, S., 2015. Prediction performance of an artificial neural network model for the amount of cooling energy consumption in hotel rooms. *Energies*, Volume 8, pp. 8226-8243.
- 70.Moreno, J. J. M., Pol, A. P., Abad, A. S. & Blasco, B. C., 2013. Using the R-MAPE index as a resistant measure of forecast accuracy. *Psicothema*, Volume 25(4), pp. 500-506.
- 71.Muhaisen, A., 2015. Effect of wall thermal properties on the energy consumption of buildings in the Gaza strip. 2nd International Sustainable Buildings Symposium, Ankara, Turkey.
- 72.Negendahl, K., 2015. Building performance simulation in the early design stage: An introduction to integrated dynamic models. *Automation in Construction*, Volume 54, pp. 39–53.
- 73.Neto, A. H. & Fiorelli, F. A. S., 2008. Comparison between detailed model simulation and artificial neural network for forecasting building energy consumption. *Energy and buildings*, Volume 40(12), pp. 2169-2176.
- 74.Peurifoy, R. L. & Oberlender , G. D., 2002. *Estimating Construction Costs*. 5th Edition, McGraw-Hill, New Yourk.
- 75.Pham, H., 2006. *Springer Handbook of Engineering Statistics*. Springer, New Jersey.

76. Pietarila, E., 2013. Improving energy performance of office buildings based on light building information model (BIM). Master's Thesis, Aalto University, Espoo, Finland.
77. Pratt, K. B. & Bosworth, D. E., 2011. A method for the design and analysis of parametric building energy models. In Proceedings of Building Simulation 2011: 12th Conference of International Building Performance Association, Sydney, Australia.
78. Rallapalli, H. S., 2010. A comparison of EnergyPlus and eQUEST whole building energy simulation results for a medium sized office building. Doctoral Dissertation, Arizona State University, Arizona, USA.
79. Reffat, R. M., 2004. Sustainable development of buildings and environment. In Proceedings of 2nd International Conference on Development and Environment, Assiut University, Assiut, Egypt.
80. Rohles Jr., F. H., 2007. Temperature & Temperment: A psychologist looks at comfort. *Ashrae Journal*, Volume 49(2), pp. 14.
81. Samaan, M. M., Farag, O. & Khalil, M., 2016. Using simulation tools for optimizing cooling loads and daylighting levels in Egyptian campus buildings. *HBRC Journal*.
82. Samuelson, H., Claussnitzer, S., Goyal, A. & Chen, Y., 2016. Parametric energy simulation in early design: High-rise residential buildings in urban contexts. *Building and Environment*, Volume 101, pp. 19-31.
83. Samuelson, H. et al., 2016. Parametric energy simulation in early design: High-rise residential buildings in urban contexts. *Building and Environment*, Volume 101, pp. 19-31.

84. Santos, L., Schleicher, S. & Caldas, L., 2017. Automation of CAD models to BEM models for performance based goal-oriented design methods. *Building and Environment*, Volume 112, pp. 144-158.
85. Sodikov, J., 2005. Cost estimation of highway projects in developing countries: artificial neural network approach. *Journal of the Eastern Asia Society for Transportation Studies*, Volume 6, pp. 1036 - 1047.
86. Solemma, L., 2015. Solemma, LCC. [Online] Available at: <http://www.solemma.net/> [Accessed 2015].
87. Spitler, J. D., 2009. Load calculation applications manual. [book] Second Edition, ASHRAE, Atlanta.
88. Touloupaki, E. & Theodosiou, T., 2016. Energy performance optimization as a generative design tool for nearly Zero Energy Buildings. *Procedia Engineering*, Volume 180, pp. 1178-1185.
89. Tuhus-Dubrow, D. & Krarti, M., 2010. Genetic-algorithm based approach to optimize building envelope design for residential buildings. *Building and environment*, Volume 45(7), pp. 1574-1581.
90. Turhan, C. et al., 2014. Comparative study of a building energy performance software (KEP-IYTE-ESS) and ANN-based building heat load estimation. *Energy and Buildings*, Volume 85, pp. 115-125.
91. Umar, U. A. et al., 2016. Application of structural building information modeling (S-BIM) for sustainable buildings design and waste reduction: a review. *International Journal of Applied Engineering Research*, Volume 11(2), pp. 1523-1532.

92. Villamil, A., 2014. Environmentally responsive buildings: multi-objective optimization workflow for daylight and thermal quality. Master's Thesis, University of Southern California, California, USA.
93. Wang, W., 2005. A simulation-based optimization system for green building design. Doctoral Dissertation, Concordia University, Montreal.
94. Wang, W., Rivard, H. & Zmeureanu, R., 2006. Floor shape optimization for green building design. *Advanced Engineering Informatics*, Volume 20(4), pp. 363–378.
95. Wang, W., Zmeureanu, R. & Rivard, H., 2005. Applying multi-objective genetic algorithms in green building design optimization. *Building and Environment*, Volume 40, pp. 1512–1525.
96. Wong, S., Wan, K. K. & Lam, T. N., 2010. Artificial neural networks for energy analysis of office buildings with daylighting. *Applied Energy*, Volume 87(2), pp. 551-557.
97. Yang, M.-D., Lin, M.-D., Lin, Y.-H. & Tsai, K.-T., 2017. Multiobjective optimization design of green building envelope material using a non-dominated sorting genetic algorithm. *Applied Thermal Engineering*, Volume 111, pp. 1255-1264.
98. Zhao, H., 2011. Artificial intelligence models for large scale buildings energy consumption analysis. Doctoral dissertation, Ecole centrale de Paris, Châtenay-Malabry, France.
99. Zhao, H.-X. & Magoulès, F., 2012. Feature selection for predicting building energy consumption based on statistical learning method. *Journal of Algorithms & Computational Technology*, Volume 6(1), pp. 59-77.

APPENDIX 1

A customized component developed in Grasshopper using Python scripting

```
/// </summary>
public class Script_Instance : GH_ScriptInstance
{
#region Utility functions
    /// <summary>Print a String to the [Out] Parameter of the Script component.</summary>
    /// <param name="text">String to print.</param>
    private void Print(string text) { /* Implementation hidden. */ }
    /// <summary>Print a formatted String to the [Out] Parameter of the Script
component.</summary>
    /// <param name="format">String format.</param>
    /// <param name="args">Formatting parameters. </param>
    private void Print(string format, params object[] args) { /* Implementation hidden. */ }
    /// <summary>Print useful information about an object instance to the [Out] Parameter of the
Script component. </summary>
    /// <param name="obj">Object instance to parse.</param>
    private void Reflect(object obj) { /* Implementation hidden. */ }
    /// <summary>Print the signatures of all the overloads of a specific method to the [Out]
Parameter of the Script component. </summary>
    /// <param name="obj">Object instance to parse.</param>
    private void Reflect(object obj, string method_name) { /* Implementation hidden. */ }
#endregion
#region Members
    /// <summary>Gets the current Rhino document.</summary>
    private readonly RhinoDoc RhinoDocument;
    /// <summary>Gets the Grasshopper document that owns this script.</summary>
    private readonly GH_Document GrasshopperDocument;
    /// <summary>Gets the Grasshopper script component that owns this script.</summary>
```

```

private readonly IGH_Component Component;
/// <summary>
/// Gets the current iteration count. The first call to RunScript() is associated with Iteration==0.
/// Any subsequent call within the same solution will increment the Iteration count.
/// </summary>
private readonly int Iteration;
#endregion
/// <summary>
/// This procedure contains the user code. Input parameters are provided as regular arguments,
/// Output parameters as ref arguments. You don't have to assign output parameters,
/// they will have a default value.
/// </summary>
private void RunScript(List<System.Object> mySliders, bool runAll)
{
    if (!runAll)
        return;
    if (_running)
        return;
    //if (!System.IO.Directory.Exists(folder))
    // System.IO.Directory.CreateDirectory(folder);
    // _folder = folder;
    _run = true;
    _mySliders = mySliders;
    GrasshopperDocument.SolutionEnd += OnSolutionEnd;
}
// <Custom additional code>
private bool _run = false;
private bool _running = false;
private string _folder;

```

```

private List<System.Object> _mySliders;
private void OnSolutionEnd(object sender, GH_SolutionEventArgs e)
{
    // Unregister the event, we don't want to get called again.
    e.Document.SolutionEnd -= OnSolutionEnd;
    // If we're not supposed to run, abort now.
    if (!_run)
        return;
    // If we're already running, abort now.
    if (_running)
        return;
    // Reset run and running states.
    _run = false;
    _running = true;
    try
    {
        // Find the Guid for connected slides
        List<System.Guid> guids = new List<System.Guid>();
        Grasshopper.Kernel.IGH_Param selSlidersInput = Component.Params.Input[0];
        IList<Grasshopper.Kernel.IGH_Param> sources = selSlidersInput.Sources;
        bool isMySlidersEmpty = !sources.Any();
        if (!isMySlidersEmpty) {
            foreach (var source in sources)
            {
                IGH_DocumentObject component = source.Attributes.GetTopLevel.DocObject;
                Grasshopper.Kernel.Special.GH_NumberSlider mySlider = component as
                Grasshopper.Kernel.Special.GH_NumberSlider;
                if (mySlider == null)
                    continue;
            }
        }
    }
}

```

```

        guides.Add(mySlider.InstanceGuid);
    }
}
// Find all sliders.
List<Grasshopper.Kernel.Special.GH_NumberSlider> sliders = new
List<Grasshopper.Kernel.Special.GH_NumberSlider>();
foreach (IGH_DocumentObject docObject in GrasshopperDocument.Objects)
{
    Grasshopper.Kernel.Special.GH_NumberSlider slider = docObject as
Grasshopper.Kernel.Special.GH_NumberSlider;
    if (slider != null)
    {
        // check if the slider is in the selected list
        if (!isMySlidersEmpty)
        {
            if (guids.Contains(slider.InstanceGuid)) sliders.Add(slider);
        }
        else
        {
            sliders.Add(slider);
        }
    }
}
if (sliders.Count == 0)
{
    System.Windows.Forms.MessageBox.Show("No sliders could be found", "<harsh buzzing
sound>", MessageBoxButtons.OK);
    return;
}

```

```

// Set all sliders back to zero.
//GH_Document.EnableSolutions = false;
foreach (Grasshopper.Kernel.Special.GH_NumberSlider slider in sliders)
    slider.TickValue = 0;

// Start a giant loop in which we'll permutate our way across all slider layouts.
//int imageNumber = 0;
while (true)
{
    int idx = 0;
    if (!MoveToNextPermutation(ref idx, sliders))
        break;

    // We've just got a new valid permutation. Solve the new solution.
    e.Document.NewSolution(false);
    Rhino.RhinoDoc.ActiveDoc.Views.Redraw();
    /*
    Rhino.Display.RhinoView view = RhinoDocument.Views.Find("Perspective", false);
    if (view == null)
        break;
    string fileName = string.Format("{0}\\{1}.png", _folder, imageNumber);
    imageNumber++;
    Bitmap image = view.CaptureToBitmap();
    if (image == null)
        continue;
    image.Save(fileName);
    image.Dispose();
    image = null;
    */
}

```

```

    }
}
catch(Exception ex)
{
    // Ehm, exception, best swallow it here lest it totally crashes everything.
}
finally
{
    // Always make sure that _running is switched off.
    _running = false;
}
}

private bool MoveToNextPermutation(ref int index,
List<Grasshopper.Kernel.Special.GH_NumberSlider> sliders)
{
    if (index >= sliders.Count)
        return false;
    Grasshopper.Kernel.Special.GH_NumberSlider slider = sliders[index];
    if (slider.TickValue < slider.TickCount)
    {
        // Increment the slider.
        slider.TickValue++;
        return true;
    }
    else
    {
        // The current slider is already at the maximum value. Reset it back to zero.
        slider.TickValue = 0;
    }
}

```

```
// Move on to the next slider.  
index++;  
// If we've run out of sliders to modify, we're done permutatin'  
if (index >= sliders.Count)  
    return false;  
return MoveToNextPermutation(ref index, sliders);  
}  
}  
// </Custom additional code>  
}
```

APPENDIX 2

ANN model user Interface Code using VB in Microsoft Excel

Option Explicit

```
Private Sub chkResetNetwork_Click()  
resetNetwork = chkResetNetwork.Value  
End Sub
```

```
Private Sub cmdClose_Click()  
Unload Me  
Sheets("Output").Range("A2:P2").Clear  
Sheets("Input").Range("A2:P2").Clear  
End Sub
```

```
Private Sub cmdGetNetworkOutput_Click()  
'Get the network response as an array of outputs  
Dim networkResponse As Variant  
networkResponse = GetNetworkResponse  
'Get reference to output worksheet - send all output data there  
Dim outputWorksheet As Object  
Set outputWorksheet = ThisWorkbook.Worksheets("Output")  
Application.ScreenUpdating = False  
'Create column labels on output worksheet  
outputWorksheet.Cells(1, 1).Value = "Exemplar #"  
'If Desired worksheet exists, copy the data column labels from 'Desired' worksheet  
'to 'Output' worksheet. Otherwise, create Output# lables.  
Dim i As Long  
If CheckIfSheetExists("Desired") = True Then  
With ThisWorkbook.Sheets("Desired")  
If .Cells(1, 1).CurrentRegion.Columns.Count = 1 Then
```

```

        .Range(.Cells(1, 1), .Cells(1, 1)).Copy
    Else
        .Range(.Cells(1, 1), .Cells(1, 1).End(xlToRight)).Copy
    End If
End With
outputWorksheet.Paste Destination:=outputWorksheet.Cells(1, 2)
Else
    For i = LBound(networkResponse, 2) To UBound(networkResponse, 2)
        outputWorksheet.Cells(1, i + 2) = "Output" & i + 1
    Next
End If
'Create column of exemplar numbers
For i = LBound(networkResponse, 1) To UBound(networkResponse, 1)
    outputWorksheet.Cells(i + 2, 1) = i + 1
Next
'Fill the rest of the worksheet with output data values
FillCellsFrom2DArray networkResponse, "Output", 2, 2
Application.ScreenUpdating = True
'Display message in network output text box control telling user to view
'the 'Output' worksheet
txtNetworkOutput.Caption = "Check 'Output' worksheet for results."
'Make the 'Output' worksheet active so output values can be seen
outputWorksheet.Activate
'Me.out.Text = CInt(ThisWorkbook.Sheets("output").Range("B2").Value)
Me.TextBox14.Text = CLng(ThisWorkbook.Sheets("Output").Range("B2").Value)
End Sub
Private Sub cmdTrainNetwork_Click()
    txtTrainNetwork.Text = "Training..."
    Me.Repaint

```

```

Dim trainingBestCost As Variant
trainingBestCost = TrainNetwork
txtTrainNetwork.Text = "Best Cost = " & trainingBestCost
End Sub

Private Sub ComboBox1_Change()
If ComboBox1.Text = "Wall Type 1" Then
ComboBox1.Text = "0"
End If
If ComboBox1.Text = "Wall Type 2" Then
ComboBox1.Text = "1"
End If
If ComboBox1.Text = "Wall Type 3" Then
ComboBox1.Text = "2"
End If
End Sub

Private Sub ComboBox2_Change()
If ComboBox2.Text = "Roof Type 1" Then
ComboBox2.Text = "0"
End If
If ComboBox2.Text = "Roof Type 2" Then
ComboBox2.Text = "1"
End If
End Sub

Private Sub ComboBox3_Change()
If ComboBox3.Text = "SOG Type 1" Then
ComboBox3.Text = "0"
End If
If ComboBox3.Text = "SOG Type 2" Then
ComboBox3.Text = "1"

```

```

End If
End Sub
Private Sub CommandButton1_Click()
Dim QQ As Integer
TextBox5.Value = CStr((Val(TextBox5.Value) / 100) ^ 0.5)
TextBox6.Value = CStr((Val(TextBox6.Value) / 100) ^ 0.5)
TextBox7.Value = CStr((Val(TextBox7.Value) / 100) ^ 0.5)
TextBox8.Value = CStr((Val(TextBox8.Value) / 100) ^ 0.5)
Range("A2").Select
Sheets("Input").Activate
ActiveCell.Offset.Value = Me.ComboBox1.Text
ActiveCell.Offset(0, 1).Value = Me.ComboBox2.Text
ActiveCell.Offset(0, 2).Value = Me.ComboBox3.Text
ActiveCell.Offset(0, 3).Value = Me.TextBox1.Text
ActiveCell.Offset(0, 4).Value = Me.TextBox2.Text
ActiveCell.Offset(0, 5).Value = Me.TextBox3.Text
ActiveCell.Offset(0, 6).Value = Me.TextBox4.Text
ActiveCell.Offset(0, 7).Value = Me.TextBox5.Text
ActiveCell.Offset(0, 8).Value = Me.TextBox6.Text
ActiveCell.Offset(0, 9).Value = Me.TextBox7.Text
ActiveCell.Offset(0, 10).Value = Me.TextBox8.Text
ActiveCell.Offset(0, 11).Value = Me.TextBox9.Text
ActiveCell.Offset(0, 12).Value = Me.TextBox10.Text
ActiveCell.Offset(0, 13).Value = Me.TextBox11.Text
ActiveCell.Offset(0, 14).Value = Me.TextBox12.Text
ActiveCell.Offset(0, 15).Value = Me.TextBox13.Text
End Sub
Private Sub CommandButton2_Click()
Me.ComboBox1.Text = Empty

```

```
Me.ComboBox2.Text = Empty
Me.ComboBox3.Text = Empty
Me.TextBox1.Text = Empty
Me.TextBox2.Text = Empty
Me.TextBox3.Text = Empty
Me.TextBox4.Text = Empty
Me.TextBox5.Text = Empty
Me.TextBox6.Text = Empty
Me.TextBox7.Text = Empty
Me.TextBox8.Text = Empty
Me.TextBox9.Text = Empty
Me.TextBox10.Text = Empty
Me.TextBox11.Text = Empty
Me.TextBox12.Text = Empty
Me.TextBox13.Text = Empty
Me.TextBox14.Text = Empty
Me.ComboBox1.SetFocus
End Sub
Private Sub TextBox9_Change()
End Sub
Private Sub UserForm_Initialize()
    resetNetwork = True
    chkResetNetwork.Value = True
    If RECALL_ONLY_NETWORK = True Then
        txtTrainNetwork.Text = "Recall Network Only."
        cmdTrainNetwork.Enabled = False
        chkResetNetwork.Enabled = False
    Else
        txtTrainNetwork.Text = "Not tested."
```

```

    End If
    ' txtNetworkOutput.Caption = "Not tested."
    Me.Repaint
With ComboBox1
.AddItem "Wall Type 1"
.AddItem "Wall Type 2"
.AddItem "Wall Type 3"
End With
With ComboBox2
.AddItem "Roof Type 1"
.AddItem "Roof Type 2"
End With
With ComboBox3
.AddItem "SOG Type 1"
.AddItem "SOG Type 2"
End With
End Sub
Function CheckIfSheetExists(sheetName As String) As Boolean
    On Error Resume Next
    sheetName = ThisWorkbook.Sheets(sheetName).Name
    If Err = 0 Then
        CheckIfSheetExists = True
    Else
        CheckIfSheetExists = False
    End If
    On Error GoTo 0
End Function

```

APPENDIX 3

Visual basic code for the optimization model

```
Private Sub Command1_Click()
Randomize      'Start of Macro by initializing variables
'Dim xlapp As Object
'Set xlapp = CreateObject("excel.application")
'fileName = "c:\sfla.xls"
'xlapp.Application.Workbooks.Open fileName
'xlapp.Application.Visible = True

Dim msg, title As String
Dim genebest() As Double
Dim relmerit() As Double
Dim e As Double
Dim moderrors() As Double
Dim var1, var2, var3 As Single
Dim ind, i, j, jo, m, k, gene1, gene2 As Integer
Dim identical As Integer
Dim genr As Long

    nTasks = Val(Text4.Text)
    popul = Val(Text2.Text)
    If popul = 0 Then End
    varMin = Val(Text5.Text)      'Minimum value for variables
    varMax = Val(Text6.Text)     'Maximum value for variables
noofruns = 1
For nn = 1 To noofruns
best_option = 10000000
    ReDim errors(popul + 1) As Double
    ReDim gene(popul + 1, nTasks) As Double
    ReDim relmerit(popul) As Double
    ReDim errors(popul + 1) As Double
    ReDim moderrors(popul) As Double
    ReDim genebest(nTasks) As Double
'genr = genr + 5000
Dim Wall, Roof, SOG, Length, Depth, Height, Orientation, Heating_SP, Cooling_SP As Integer
Dim South, East, Nourth, West, UValue, SHGC, VT As Double

noofsolutions = 0

    start = Time: last = start
```

```

totmerit = 0
For k = 0 To popul + 1      'generate population of random chromosomes
    mo = Rnd: Wall = CInt((0 + (2 - 0)) * Rnd)
    mo = Rnd: Roof = CInt(0 + (1 - 0) * Rnd)
    mo = Rnd: SOG = CInt(0 + (1 - 0) * Rnd)
    mo = Rnd: Length = txtLength.Text
    mo = Rnd: Depth = txtDepth.Text
    mo = Rnd: Height = txtHeight.Text
    mo = Rnd: Orientation = CInt(0 + (360 - 0) * Rnd)
    mo = Rnd: South = 0.31622 + (0.8944 - 0.31622) * Rnd
    mo = Rnd: East = 0.31622 + (0.8944 - 0.31622) * Rnd
    mo = Rnd: Nourth = 0.31622 + (0.8944 - 0.31622) * Rnd
    mo = Rnd: West = 0.31622 + (0.8944 - 0.31622) * Rnd
    mo = Rnd: UValue = 0.1 + (1.2 - 0.1) * Rnd
    mo = Rnd: SHGC = 0.1 + (1 - 0.1) * Rnd
    mo = Rnd: VT = 0.1 + (1 - 0.1) * Rnd
    mo = Rnd: Heating_SP = CInt(8 + (12 - 8) * Rnd)
    mo = Rnd: Cooling_SP = CInt(18 + (28 - 18) * Rnd)

    gene(k, 0) = Wall
    gene(k, 1) = Roof
    gene(k, 2) = SOG
    gene(k, 3) = Length
    gene(k, 4) = Depth
    gene(k, 5) = Height
    gene(k, 6) = Orientation
    gene(k, 7) = South
    gene(k, 8) = East
    gene(k, 9) = Nourth
    gene(k, 10) = West
    gene(k, 11) = UValue
    gene(k, 12) = SHGC
    gene(k, 13) = VT
    gene(k, 14) = Heating_SP
    gene(k, 15) = Cooling_SP

Next k

Dim fname1 As String
fname1 = DATA_PATH & "\" & "InputData.txt"
Open fname1 For Output As #1

Print #1, "Wall" & vbTab & "Roof" & vbTab & "S.O.G" & vbTab & "Length" & vbTab &
"Depth" & vbTab & "Height" & vbTab & "Orientation" & vbTab & "South" & vbTab & "East" &

```

```

vbTab & "Nourth" & vbTab & "West" & vbTab & "UValue" & vbTab & "SHGC" & vbTab &
"VT" & vbTab & "Heating_SP" & vbTab & "Cooling_SP"
    For i = 1 To popul
        Print #1, gene(i, 0) & vbTab & gene(i, 1) & vbTab & gene(i, 2) & vbTab & gene(i, 3) &
vbTab & gene(i, 4) & vbTab & gene(i, 5) & vbTab & gene(i, 6) & vbTab & gene(i, 7) & vbTab &
gene(i, 8) & vbTab & gene(i, 9) & vbTab & gene(i, 10) & vbTab & gene(i, 11) & vbTab & gene(i,
12) & vbTab & gene(i, 13) & vbTab & gene(i, 14) & vbTab & gene(i, 15)
    Next

Close #1
Call cost_calc 'check every chromosome
ReDim Trial_1(popul) As String
For i = 0 To popul
    Trial_1(i) = Outs(i)
Next
For i = 0 To popul - 1
    SUMMATION = SUMMATION + 1 / Outs(i)
Next

Dim fname2 As String
fname2 = DATA_PATH & "\" & "Output Data.txt"
Open fname2 For Output As #1
For i = 0 To popul - 1
    Print #1, i + 1 & vbTab & Format(gene(i, 0), "#0.00") & vbTab & Format(gene(i, 1), "#0.00")
& vbTab & Format(gene(i, 2), "#0.00") & vbTab & Format(gene(i, 3), "#0.00") & vbTab &
Format(gene(i, 4), "#0.00") & vbTab & Format(gene(i, 5), "#0.00") & vbTab & Format(gene(i, 6),
"#0.00") & vbTab & Format(gene(i, 7), "#0.00") & vbTab & Format(gene(i, 8), "#0.00") & vbTab
& Format(gene(i, 9), "#0.00") & vbTab & Format(gene(i, 10), "#0.00") & vbTab & Format(gene(i,
11), "#0.00") & vbTab & Format(gene(i, 12), "#0.00") & vbTab & Format(gene(i, 13), "#0.00")
& vbTab & Format(gene(i, 14), "#0.00") & vbTab & Format(gene(i, 15), "#0.00") & vbTab &
Format(Outs(i), "#0.00") & vbTab & Format(1 / Outs(i), "#0.000000") & vbTab & (1 / Outs(i))
* 100 / SUMMATION
Next
Close #1
Dim noCycles, noRounds As Integer
noCycles = txtGeneration.Text
noRounds = 50
Dim Res() As String
ReDim Res(noCycles, 2) As String
Dim Last_worriest As Double

Dim Worrest, Best As Double
Dim Worrest_ID, Best_ID As Integer
Dim Cycle_Best As Double
Dim Counter_1 As Integer
Dim Counter_2 As Integer

```

```

Counter_1 = 0
Counter_2 = 0
Cycle_Best = 100000000000#

For xx = 1 To noCycles
If (Counter_1 >= 10) Then
    GoTo 5000
End If

For z = 1 To noRounds
100:
    Worrest = 0
    Best = 10000000
    Worrest_ID = 0
    Best_ID = 0

    Dim Merrit() As Double
    ReDim Merrit(popul - 1) As Double
    Dim xxxxx As Double
    xxxxx = 0

    For i = 0 To popul - 1
        If (Outs(i) > Worrest) Then
            Worrest = Outs(i)
            Worrest_ID = i
        End If

        If (Outs(i) < Best) Then
            Best = Outs(i)
            Best_ID = i
        End If

        Merrit(i) = xxxxx + (1 / Outs(i)) * 100 / SUMMATION
        xxxxx = Merrit(i)
    Next

    Dim Pcrossover, rand_1 As Double
    Pcrossover = 0.7

200:
    mo = Rnd: RandNo = CInt(1 + (100 - 1) * Rnd) / 100
    ' RandNo = 0.99

    Dim RandNo_1, RandNo_2 As Double
    RandNo_1 = 0
    RandNo_2 = 0

```

```
mo = Rnd: RandNo_1 = CInt(0.001 + (100 - 0.001) * Rnd)
mo = Rnd: RandNo_2 = CInt(0.001 + (100 - 0.001) * Rnd)
```

```
Dim Rnd_ID_1, Rnd_ID_2 As Integer
Dim chck1, chck2 As Integer
chck1 = 0
chck2 = 0
```

```
For i = 0 To popul - 1
  If (chck1 < 1) Then
    If (Merrit(i) > RandNo_1) Then
      Rnd_ID_1 = i + 1
      chck1 = chck1 + 1
    End If
  End If
```

```
  If (chck2 < 1) Then
    If (Merrit(i) > RandNo_2) Then
      Rnd_ID_2 = i + 1
      chck2 = chck2 + 1
    End If
  End If
```

```
Next
If (Rnd_ID_1 = Rnd_ID_2) Then
  GoTo 200
End If
```

```
fname1 = DATA_PATH & "\" & "InputData.txt"
Open fname1 For Output As #1
```

```
If (RandNo < Pcrossover) Then
  Dim RANDCROSS1, RANDCROSS2, RANDCROSS3 As Double
```

12:

```
mo = Rnd: RANDCROSS1 = CInt(1 + (100 - 1) * Rnd) / 100
mo = Rnd: RANDCROSS2 = CInt(1 + (100 - 1) * Rnd) / 100
mo = Rnd: RANDCROSS3 = CInt(1 + (100 - 1) * Rnd) / 100
```

```
Dim SELECT1, SELECT2, SELECT3 As Integer
SELECT1 = CInt(RANDCROSS1 * 15)
SELECT2 = CInt(RANDCROSS2 * 15)
SELECT3 = CInt(RANDCROSS3 * 15)
```

```
If ((SELECT1 >= SELECT2) Or (SELECT1 >= SELECT3)) Then
```

```

    GoTo 12
End If
If (SELECT2 >= SELECT3) Then
    GoTo 12
End If

Dim CHILD() As Double
ReDim CHILD(16) As Double

For cc = 0 To 15
    If ((cc <= SELECT1) Or (cc > SELECT3)) Then
        CHILD(cc) = gene(Rnd_ID_1 - 1, cc)
    Else
        CHILD(cc) = gene(Rnd_ID_2 - 1, cc)
    End If
Next
Print #1, "Wall" & vbTab & "Roof" & vbTab & "S.O.G" & vbTab & "Length" & vbTab &
"Depth" & vbTab & "Height" & vbTab & "Orientation" & vbTab & "South" & vbTab & "East" &
vbTab & "Nourth" & vbTab & "West" & vbTab & "UValue" & vbTab & "SHGC" & vbTab &
"VT" & vbTab & "Heating_SP" & vbTab & "Cooling_SP"
Print #1, CHILD(0) & vbTab & CHILD(1) & vbTab & CHILD(2) & vbTab & CHILD(3) &
vbTab & CHILD(4) & vbTab & CHILD(5) & vbTab & CHILD(6) & vbTab & CHILD(7) & vbTab &
CHILD(8) & vbTab & CHILD(9) & vbTab & CHILD(10) & vbTab & CHILD(11) & vbTab &
CHILD(12) & vbTab & CHILD(13) & vbTab & CHILD(14) & vbTab & CHILD(15)
Else
    Dim MUT_ID As Double
    RandNo_1 = Rnd_ID_1
    Dim RANDMUT As Double
15:
    mo = Rnd: RANDMUT = CInt(1 + (100 - 1) * Rnd) * 16 / 100
    For i = 0 To popul - 1
        If (chck1 < 1) Then
            If (Merrit(i) > RandNo_1) Then
                Rnd_ID_1 = i + 1
                chck1 = chck1 + 1
            End If
        End If
    Next
    If (RANDMUT = 3 Or RANDMUT = 4 Or RANDMUT = 5) Then
        GoTo 15
    End If
    If (RANDMUT = 0) Then
        mo = Rnd: Wall = CInt((0 + (2 - 0)) * Rnd)
    Else
        Wall = gene(RandNo_1 - 1, 0)

```

End If

If (RANDMUT = 1) Then
mo = Rnd: Roof = CInt(0 + (1 - 0) * Rnd)
Else
Roof = gene(RandNo_1 - 1, 1)
End If

If (RANDMUT = 2) Then
mo = Rnd: SOG = CInt(0 + (1 - 0) * Rnd)
Else
SOG = gene(RandNo_1 - 1, 2)
End If

mo = Rnd: Length = txtLength.Text
mo = Rnd: Depth = txtDepth.Text
mo = Rnd: Height = txtHeight.Text

If (RANDMUT = 6) Then
mo = Rnd: Orientation = CInt(0 + (360 - 0) * Rnd)
Else
Orientation = gene(RandNo_1 - 1, 6)
End If

If (RANDMUT = 7) Then
mo = Rnd: South = 0.31622 + (0.8944 - 0.31622) * Rnd
Else
South = gene(RandNo_1 - 1, 7)
End If

If (RANDMUT = 8) Then
mo = Rnd: East = 0.31622 + (0.8944 - 0.31622) * Rnd
Else
East = gene(RandNo_1 - 1, 8)
End If

If (RANDMUT = 9) Then
mo = Rnd: Nourth = 0.31622 + (0.8944 - 0.31622) * Rnd
Else
Nourth = gene(RandNo_1 - 1, 9)
End If

If (RANDMUT = 10) Then
mo = Rnd: West = 0.31622 + (0.8944 - 0.31622) * Rnd
Else
West = gene(RandNo_1 - 1, 10)

```

End If

If (RANDMUT = 11) Then
    mo = Rnd: UValue = 0.1 + (1.2 - 0.1) * Rnd
Else
    UValue = gene(RandNo_1 - 1, 11)
End If

If (RANDMUT = 12) Then
    mo = Rnd: SHGC = 0.1 + (1 - 0.1) * Rnd
Else
    SHGC = gene(RandNo_1 - 1, 12)
End If

If (RANDMUT = 13) Then
    mo = Rnd: VT = 0.1 + (1 - 0.1) * Rnd
Else
    VT = gene(RandNo_1 - 1, 13)
End If

If (RANDMUT = 14) Then
    mo = Rnd: Heating_SP = CInt(8 + (12 - 8) * Rnd)
Else
    Heating_SP = gene(RandNo_1 - 1, 14)
End If

If (RANDMUT = 15) Then
    mo = Rnd: Cooling_SP = CInt(18 + (28 - 18) * Rnd)
Else
    Cooling_SP = gene(RandNo_1 - 1, 15)
End If

Print #1, "Wall" & vbTab & "Roof" & vbTab & "S.O.G" & vbTab & "Length" & vbTab &
"Depth" & vbTab & "Height" & vbTab & "Orientation" & vbTab & "South" & vbTab & "East" &
vbTab & "Nourth" & vbTab & "West" & vbTab & "UValue" & vbTab & "SHGC" & vbTab &
"VT" & vbTab & "Heating_SP" & vbTab & "Cooling_SP"
Print #1, Wall & vbTab & Roof & vbTab & SOG & vbTab & Length & vbTab & Depth &
vbTab & Height & vbTab & Orientation & vbTab & South & vbTab & East & vbTab & Nourth
& vbTab & West & vbTab & UValue & vbTab & SHGC & vbTab & VT & vbTab & Heating_SP
& vbTab & Cooling_SP
End If

Close #1

Call cost_calc 'check every chromosome

```

```

fname2 = DATA_PATH & "\" & "Output Data.txt"
Open fname2 For Output As #1
If (RandNo < Pcrossover) Then
    Print #1, "Child" & vbTab & Format(CHILD(0), "#0.00") & vbTab & Format(CHILD(1),
"#0.00") & vbTab & Format(CHILD(2), "#0.00") & vbTab & Format(CHILD(3), "#0.00") &
vbTab & Format(CHILD(4), "#0.00") & vbTab & Format(CHILD(5), "#0.00") & vbTab &
Format(CHILD(6), "#0.00") & vbTab & Format(CHILD(7), "#0.00") & vbTab &
Format(CHILD(8), "#0.00") & vbTab & Format(CHILD(9), "#0.00") & vbTab &
Format(CHILD(10), "#0.00") & vbTab & Format(CHILD(11), "#0.00") & vbTab &
Format(CHILD(12), "#0.00") & vbTab & Format(CHILD(13), "#0.00") & vbTab &
Format(CHILD(14), "#0.00") & vbTab & Format(CHILD(15), "#0.00") & vbTab &
Format(Outs(0), "#0.00")
    Else
        Print #1, "mutation" & vbTab & Format(Wall, "#0.00") & vbTab & Format(Roof, "#0.00")
& vbTab & Format(SOG, "#0.00") & vbTab & Format(Length, "#0.00") & vbTab &
Format(Depth, "#0.00") & vbTab & Format(Height, "#0.00") & vbTab & Format(Orientation,
"#0.00") & vbTab & Format(South, "#0.00") & vbTab & Format(East, "#0.00") & vbTab &
Format(Nourth, "#0.00") & vbTab & Format(West, "#0.00") & vbTab & Format(UValue, "#0.00")
& vbTab & Format(SHGC, "#0.00") & vbTab & Format(VT, "#0.00") & vbTab &
Format(Heating_SP, "#0.00") & vbTab & Format(Cooling_SP, "#0.00") & vbTab &
Format(Outs(0), "#0.00")
    End If

Close #1

If (Outs(0) < Worrest) Then
If (RandNo < Pcrossover) Then
    gene(Worrest_ID, 0) = CHILD(0)
    gene(Worrest_ID, 1) = CHILD(1)
    gene(Worrest_ID, 2) = CHILD(2)
    gene(Worrest_ID, 3) = CHILD(3)
    gene(Worrest_ID, 4) = CHILD(4)
    gene(Worrest_ID, 5) = CHILD(5)
    gene(Worrest_ID, 6) = CHILD(6)
    gene(Worrest_ID, 7) = CHILD(7)
    gene(Worrest_ID, 8) = CHILD(8)
    gene(Worrest_ID, 9) = CHILD(9)
    gene(Worrest_ID, 10) = CHILD(10)
    gene(Worrest_ID, 11) = CHILD(11)
    gene(Worrest_ID, 12) = CHILD(12)
    gene(Worrest_ID, 13) = CHILD(13)
    gene(Worrest_ID, 14) = CHILD(14)
    gene(Worrest_ID, 15) = CHILD(15)
    Trial_1(Worrest_ID) = Outs(0)
Else

```

```

gene(Worrest_ID, 0) = Wall
gene(Worrest_ID, 1) = Roof
gene(Worrest_ID, 2) = SOG
gene(Worrest_ID, 3) = Length
gene(Worrest_ID, 4) = Depth
gene(Worrest_ID, 5) = Height
gene(Worrest_ID, 6) = Orientation
gene(Worrest_ID, 7) = South
gene(Worrest_ID, 8) = East
gene(Worrest_ID, 9) = Nourth
gene(Worrest_ID, 10) = West
gene(Worrest_ID, 11) = UValue
gene(Worrest_ID, 12) = SHGC
gene(Worrest_ID, 13) = VT
gene(Worrest_ID, 14) = Heating_SP
gene(Worrest_ID, 15) = Cooling_SP
Trial_1(Worrest_ID) = Outs(0)
End If

SUMMATION = 0
For i = 0 To popul - 1
    SUMMATION = SUMMATION + 1 / Trial_1(i)
Next

fname2 = DATA_PATH & "\" & "Output Data.txt"
Open fname2 For Output As #1
For i = 0 To popul - 1
    Print #1, i + 1 & vbTab & Format(gene(i, 0), "#0.00") & vbTab & Format(gene(i, 1), "#0.00")
    & vbTab & Format(gene(i, 2), "#0.00") & vbTab & Format(gene(i, 3), "#0.00") & vbTab &
    Format(gene(i, 4), "#0.00") & vbTab & Format(gene(i, 5), "#0.00") & vbTab & Format(gene(i, 6),
    "#0.00") & vbTab & Format(gene(i, 7), "#0.00") & vbTab & Format(gene(i, 8), "#0.00") & vbTab
    & Format(gene(i, 9), "#0.00") & vbTab & Format(gene(i, 10), "#0.00") & vbTab & Format(gene(i,
    11), "#0.00") & vbTab & Format(gene(i, 12), "#0.00") & vbTab & Format(gene(i, 13), "#0.00")
    & vbTab & Format(gene(i, 14), "#0.00") & vbTab & Format(gene(i, 15), "#0.00") & vbTab &
    Format(Trial_1(i), "#0.00") & vbTab & Format(1 / Trial_1(i), "#0.0000000") & vbTab & (1 /
    Trial_1(i)) * 100 / SUMMATION
Next
Close #1

For i = 0 To popul
    Outs(i) = Trial_1(i)
Next

GoTo 300
Else
    For i = 0 To popul

```

```

    Outs(i) = Trial_1(i)
Next
GoTo 300
End If
300:

fname2 = DATA_PATH & "\Output\" & "Round #C" & xx & "-R" & z & ".txt"
Open fname2 For Output As #1
For i = 0 To popul - 1
    Print #1, i + 1 & vbTab & Format(gene(i, 0), "#0.00") & vbTab & Format(gene(i, 1), "#0.00")
    & vbTab & Format(gene(i, 2), "#0.00") & vbTab & Format(gene(i, 3), "#0.00") & vbTab &
    Format(gene(i, 4), "#0.00") & vbTab & Format(gene(i, 5), "#0.00") & vbTab & Format(gene(i, 6),
    "#0.00") & vbTab & Format(gene(i, 7), "#0.00") & vbTab & Format(gene(i, 8), "#0.00") & vbTab
    & Format(gene(i, 9), "#0.00") & vbTab & Format(gene(i, 10), "#0.00") & vbTab & Format(gene(i,
    11), "#0.00") & vbTab & Format(gene(i, 12), "#0.00") & vbTab & Format(gene(i, 13), "#0.00")
    & vbTab & Format(gene(i, 14), "#0.00") & vbTab & Format(gene(i, 15), "#0.00") & vbTab &
    Format(Trial_1(i), "#0.00") & vbTab & Format(1 / Trial_1(i), "#0.0000000") & vbTab & (1 /
    Trial_1(i)) * 100 / SUMMATION
Next
Close #1

Next
Res(Counter_2, 0) = Counter_2 + 1

If (Best < Cycle_Best) Then
    Counter_1 = 0
End If

If (Best <= Cycle_Best) Then
    Cycle_Best = Best

    fname2 = DATA_PATH & "\Output\" & "Cycle " & Counter_2 + 1 & ".txt"
    Open fname2 For Output As #1
    For i = 0 To popul - 1
        Print #1, i + 1 & vbTab & Format(gene(i, 0), "#0.00") & vbTab & Format(gene(i, 1),
        "#0.00") & vbTab & Format(gene(i, 2), "#0.00") & vbTab & Format(gene(i, 3), "#0.00") & vbTab
        & Format(gene(i, 4), "#0.00") & vbTab & Format(gene(i, 5), "#0.00") & vbTab & Format(gene(i,
        6), "#0.00") & vbTab & Format(gene(i, 7), "#0.00") & vbTab & Format(gene(i, 8), "#0.00") &
        vbTab & Format(gene(i, 9), "#0.00") & vbTab & Format(gene(i, 10), "#0.00") & vbTab &
        Format(gene(i, 11), "#0.00") & vbTab & Format(gene(i, 12), "#0.00") & vbTab & Format(gene(i,
        13), "#0.00") & vbTab & Format(gene(i, 14), "#0.00") & vbTab & Format(gene(i, 15), "#0.00")
        & vbTab & Format(Trial_1(i), "#0.00") & vbTab & Format(1 / Trial_1(i), "#0.0000000") & vbTab
        & (1 / Trial_1(i)) * 100 / SUMMATION
    Next
    Close #1

```

```

    Counter_2 = Counter_2 + 1
End If

If (Best >= Cycle_Best) Then
    Counter_1 = Counter_1 + 1
    Best = Cycle_Best
End If

Res(Counter_2, 1) = Best
Res(Counter_2, 2) = Worrest
Next

5000:
fname2 = DATA_PATH & "\Output\" & "Results.txt"
Open fname2 For Output As #1
    Print #1, "No." & vbTab & "Best" & vbTab & "Worrest"
For i = 0 To Counter_2
    Print #1, Res(i, 0) & vbTab & Res(i, 1) & vbTab & Res(i, 2)
Next

    Print #1, Best_ID + 1 & vbTab & gene(Best_ID, 0) & vbTab & gene(Best_ID, 1) & vbTab
& gene(Best_ID, 2) & vbTab & gene(Best_ID, 3) & vbTab & gene(Best_ID, 4) & vbTab &
gene(Best_ID, 5) & vbTab & gene(Best_ID, 6) & vbTab & gene(Best_ID, 7) & vbTab &
gene(Best_ID, 8) & vbTab & gene(Rnd_ID_1 - 1, 9) & vbTab & gene(Best_ID, 10) & vbTab &
gene(Best_ID, 11) & vbTab & gene(Best_ID, 12) & vbTab & gene(Best_ID, 13) & vbTab &
gene(Best_ID, 14) & vbTab & gene(Best_ID, 15)
    Close #1

OLE2.CreateLink (fname2)
OLE2.DoVerb (-1)

'If nn = 1 Then
'    xlapp.activecell.offset(1, 0).Value = "Experiment No."
'    xlapp.activecell.offset(2, 0).Value = "Start time"
'    xlapp.activecell.offset(3, 0).Value = "Best solution @"
'    xlapp.activecell.offset(4, 0).Value = "Finish time"
'    xlapp.activecell.offset(5, 0).Value = "No of cycles"
'    xlapp.activecell.offset(6, 0).Value = "Optimum value"
'    For nnn = 1 To nTasks
'        xlapp.activecell.offset(6 + nnn, 0).Value = "Var. No." & nnn
'Next nnn
'End If
'xlapp.activecell.offset(1, nn).Value = nn
'xlapp.activecell.offset(2, nn).Value = start
'xlapp.activecell.offset(3, nn).Value = last

```

```

'xlapp.activecell.offset(4, nn).Value = Time
'xlapp.activecell.offset(5, nn).Value = noofsolutions
'xlapp.activecell.offset(6, nn).Value = best_option
'For nnn = 1 To nTasks
'  xlapp.activecell.offset(6 + nnn, nn).Value = genebest(nnn)
'Next nnn
Next nn
'  msg = ""
'  msg = msg + "Genetic Algorithms (GAs) Results:"
'  msg = msg + Chr(13) + "Optimum obtained value      : " & Format(best_option,
"###0.#####0")
'  msg = msg + Chr(13) + Chr(13) + "Start of GAs Procedure : " & start
'  msg = msg + Chr(13) + Chr(13) + "Best solution obtained @ : " & last
'  msg = msg + Chr(13) + "End of GAs Procedure on: " & Time
'  msg = msg + Chr(13)
'  msg = msg + Chr(13) + "The best solution is, Variable number (Value):" + Chr(13)
'  For ik = 1 To nTasks
'    msg = msg & ik & "(" & Format(genebest(ik), "#0.#0") & ")" & " "
'  Next ik
'  k = MsgBox(msg, , "GAs Results")
End Sub

Private Sub Command2_Click()
  End
End Sub

Sub cost_calc()      'EF10 (Expandable F10 Function), min(-100), max(100)
  Dim m As Integer
  Dim valsquare As Double
  Dim oi As Integer
  evcr = 0#

'Get the network response as an array of outputs
  Dim networkResponse As Variant
  networkResponse = GetNetworkResponse

'Clear contents of the list box
'  txtNetworkOutput.Text = ""

'Get/Create the column labels for the output data
  Dim outputLabelsArray As Variant
  Dim i As Long
  If CheckIfFileOnFileSystem(DATA_PATH & "\", DESIRED_FILE_NAME) = True Then
    Dim outputLabels As String
    Open DATA_PATH & "\" & DESIRED_FILE_NAME For Input As #1
    Line Input #1, outputLabels

```

```

Close #1
'outputLabelsArray = Split(",", outputLabels, 1)
outputLabelsArray = outputLabels
Else
  ReDim outputLabelsArray(LBound(networkResponse, 2) To UBound(networkResponse, 2))
  For i = LBound(outputLabelsArray) To UBound(outputLabelsArray)
    outputLabelsArray(i) = "Output#" & i + 1
  Next i
End If

```

```

ReDim Outs(popul) As String
Dim numberOfTrailingSpaces As Integer
Dim outStr As String
'outStr = "Exemplar#"
' For i = LBound(outputLabelsArray) To UBound(outputLabelsArray)
'   numberOfTrailingSpaces = 9 - Len(outputLabelsArray(i))
'   If (numberOfTrailingSpaces > 0) Then
'     outStr = outStr & Chr(9) & outputLabelsArray(i) & Space(numberOfTrailingSpaces)
'   Else
'     outStr = outStr & Chr(9) & Left(outputLabelsArray(i), 9)
'   End If
'Next i
'outStr = outStr & vbCrLf

```

```

'Prepare output data for display in text box. Limit to 1000 rows.
Dim j As Long
Dim maxRows As Long
Dim SUMMATION As Double

```

```

SUMMATION = 0
maxRows = IIf(UBound(networkResponse, 1) > 1000, 1000, UBound(networkResponse, 1))
For i = LBound(networkResponse, 1) To UBound(networkResponse, 1)
  outStr = outStr & Format(i + 1, "00000") & " "
  For j = LBound(networkResponse, 2) To UBound(networkResponse, 2)
    outStr = Format(networkResponse(i, j), "0.0000000")
  Next j
  outStr = outStr
  Outs(i) = outStr
Next i

```

End Sub

Private Sub Form_Load()

```

resetNetwork = True
'chkResetNetwork.Value = vbChecked

'If RECALL_ONLY_NETWORK = True Then
' txtTrainNetwork.Text = "Recall Network Only."
' cmdTrainNetwork.Enabled = False
' chkResetNetwork.Enabled = False
'Else
' txtTrainNetwork.Text = "Not tested."
'End If

'txtNetworkOutput.Text = "Not tested."
End Sub

Private Sub cmdGetNetworkOutput()

End Sub
Function CheckIfFileOnFileSystem(filePath As String, fileName As String) As Boolean
'Determine if a file with the given fileName exists in the given filePath
On Error GoTo ErrorHandler
Dim filePathName As String
filePathName = filePath & fileName
If StrComp(Dir(filePathName, vbNormal), fileName, vbTextCompare) <> 0 Then
CheckIfFileOnFileSystem = False
Else
CheckIfFileOnFileSystem = True
End If
On Error GoTo 0
Exit Function
ErrorHandler:
CheckIfFileOnFileSystem = False
End Function
Private Function Split(splitChar As String, ByVal str1 As _
String, intPos As Integer)

On Error GoTo ErrorHandler
Dim Words(10000) As String

'To make it faster, use a lower number than 10000
'if you think there will be more than 10000 tokens
'in your string, use a higher number

Dim X As Integer

```

```
X = 0
For i = 1 To Len(str1)
  If Mid(str1, i, Len(splitChar)) = splitChar Then

    Words(X) = Mid(str1, 1, i - 1)
    str1 = Mid(str1, i + 1, Len(str1) - i)
    X = X + 1
    i = 0

  End If
Next

Words(X) = str1

Split = Words(intPos)

ErrorHandler:

End Function
```

APPENDIX 4

استبيان حول تقييم برنامج

Energy consumption prediction and selecting the appropriate sustainable design

السيد المهندس/.....

في البداية اود أن أشكركم على مشاركتكم في ملء هذا الاستبيان الذي يهدف الى جمع معلومات بخصوص التصميم المبدي للمباني المستدامة باعتبار استهلاك الطاقة.

في الآونة الأخيرة، هناك مستوى عال من الطلب على تصميم وبناء المباني المستدامة والتي تعنى الاهتمام بالنواحي الاقتصادية والاجتماعية والبيئية لخلق مباني صالحة للاستعمال وبالتالي فإنه يتطلب من المصممين والمهتمين بصناعة التشييد بمصر استخدام ممارسات التصميمات التي لن تسبب على المدى الطويل الاضرار التي تلحق بالبيئة. وكذلك التي ترتبط ارتباط وثيق مع الاستدامة الاقتصادية وغالبا ما تتضمن الكفاءة في استخدام الطاقة، مما يوفر المال على المدى الطويل. لذا فمن المهم تقييم استهلاك الطاقة في المباني السكنية في مصر. وكذلك هناك حاجة لنموذج يمكن الاعتماد عليه للتنبؤ باستهلاك الطاقة للمباني السكنية في مراحل التصميم الأولية خصوصا انه توجد مشكلة لتبادل البيانات بين برامج نمذجة المباني وبرامج محاكاة الطاقة.

وكذلك يعاني متخذي القرارات في مراحل التصميم من محدودية أدوات المحاكاة المتاحة خلال مراحل التصميم الأولية. هذا الاستبيان هو جزء من الرسالة المقدمة من الباحث / حسام الدين وفقى، لنيل درجة الدكتوراه في إدارة مشروعات التشييد – قسم الهندسة الانشائية – كلية الهندسة جامعة المنصورة. وتقدم هذه الدراسة ايضا التوجيه لتسهيل عملية اتخاذ القرارات لتقدير استهلاك الطاقة لنموذج ما بطريقة سهلة وكذلك اختيار التصميم الأمثل الذي يحقق اقل استهلاك للطاقة.

في النهاية نؤكد على ان البيانات المطلوبة تستخدم لأغراض البحث العلمي فقط وتخضع لكامل السرية. جزاكم الله خيرا.

الباحث

م/ حسام الدين وفقى

أولاً: البيانات الشخصية:

الاسم: التليفون:
جهة العمل: المحمول:
العنوان: البريد الإلكتروني:

ثانياً: بيانات جهة العمل:

• تصنيف جهة العمل:

□ مالك □ استشاري □ مقاول

• خبرتك السابقة في صناعة التشييد:

□ 10-5 سنوات

□ 15-10 سنة

□ 20-15 سنة فأكثر

ثالثاً: تقييم البرنامج:

بناءً على رؤيتكم وتجربتم للبرنامج، يرجى تقييم البرنامج من خلال المعايير التالية:

• Access to interface (الوصول لشاشة العرض)

□ Excellent □ Very Good □ Good □ Fair □ Poor

• Interface design (تصميم شاشة العرض)

□ Excellent □ Very Good □ Good □ Fair □ Poor

• Relevance of inputs (الترتيب المنطقي للمدخلات)

□ Excellent □ Very Good □ Good □ Fair □ Poor

• **Validity of outputs (الترتيب المنطقي للمخرجات)**

Excellent Very Good Good Fair Poor

• **Usefulness (النفعية)**

Excellent Very Good Good Fair Poor

• **Overall performance (الأداء الكلي)**

Excellent Very Good Good Fair Poor

رابعاً: أى إضافات أو تعليقات:

.....

.....

.....

.....

.....

.....

.....

.....

.....

ملخص

حديثاً، هناك مستوى عالٍ من الطلب على تصميم وبناء المباني المستدامة وذلك نظراً لارتفاع أسعار الطاقة وزيادة المخاوف البيئية. لذا فمن المهم تقييم استهلاك الطاقة في المباني لأنها تعتبر مفتاح حل مشكلة توفير الطاقة. هناك حاجة لنموذج محاكاة للطاقة يمكن الاعتماد عليه للتنبؤ باستهلاك الطاقة في المباني. وعلى وجه التحديد عدم وجود مثل هذه النماذج التي تتوافق مع الأجواء الحارة التي تحقق الراحة الحرارية داخل المباني. أيضاً يعاني متخذي القرارات التصميمية من محدودية أدوات المحاكاة المتاحة خلال مراحل التصميم الأولية والتي يحدد فيها الإطار الخارجي للمبنى واتجاهات المبنى. تقترح هذه الدراسة استراتيجية لإظهار نتائج التحليل البارومتري للطاقة خلال مراحل التصميم الأولية للمباني السكنية في مصر. تم بناء نموذج لمبنى سكني باستخدام كلا من برامج التصميم البارومتري وبرامج نمذجة ومحاكاة الطاقة كوسيلة لإنشاء قاعدة بيانات لاستهلاك الطاقة للمبنى. ثم تم استخدام طريقة التنسيق المتوازي لإظهار قاعدة البيانات التي تشمل مدخلات ومخرجات عمليات المحاكاة لحساب الطاقة مما يسهل لصناع القرار تقييم أداء الطاقة والراحة الحرارية داخل المبنى بمرونة عالية. واستخدمت الشبكات العصبية الاصطناعية لبناء نموذج للتنبؤ باستهلاك الطاقة باستخدام قاعدة البيانات لتعليم الشبكة وتدريبها بالاعتماد على فكرة عرض البيانات التدريبية أمام الشبكة على هيئة زوج من الأشكال وهما الشكل المدخل والشكل المستهدف. حيث تقوم الشبكة بحساب قيم الخطأ من خلال الفرق بين ناتج الشبكة والناتج المستهدف ويتم تعديل قيم الأوزان عن طريق دالة الخطأ بهدف تصغير الفارق عن طريق اشتقاق هذا التابع بالنسبة للأوزان. وخلال التدريب تتغير هذه الأوزان بشكل تكراري لغاية الوصول إلى القيمة الصغرى للخطأ. وتقدم هذه الدراسة أيضاً التوجيه لتسهيل عملية اختيار التصميم المبدئي الأمثل للمبنى وذلك عن طريق ربط كلا من الخوارزميات الجينية بالشبكات العصبية الاصطناعية. والتي تقوم فكرته على توليد عدد كبير من الحلول الممكنة لتصميم مبدئي لمبنى ما. وبعد ذلك يتم تقييم كل حل عن طريق التنبؤ باستهلاك الطاقة من خلال استخدام الشبكات العصبية الاصطناعية وتكون الأفضل فرص أكبر لتوليد حلول أخرى في حين تقل فرص تولد الحلول السيئة. وبتكرار هذه العملية تتطور نوعية الحلول المطروحة وتصل أو تقترب من الحل الأمثل.



جامعة المنصورة
كلية الهندسة
قسم الهندسة الإنشائية

إقرار نشر بحث مستخرج من رسالة

أقر انا المهندس / حسام الدين وفقى على السيد
المسجل لدرجة: دكتوراه الفلسفة في الهندسة الإنشائية (ادرة مشروعات تشييد)
عنوان الرسالة: التصميم المبدئي للمباني المستدامة باعتبار استهلاك الطاقة باستخدام المحاكاة والشبكات العصبية الاصطناعي

لجنة الاشراف:

- 1 أ.د/ عماد السعيد البلتاجي
- 2 أ.د/ سعد الدين مصطفى عبد ربه
- 3 د/ محمود حسيني داوود
- 4 د/ أحمد رمزي عباس

بالالتزام بقوانين جامعة المنصورة وأنظمتها وتعليماتها وقراراتها السارية المفعول والمتعلقة بإعداد رسائل الدكتوراه عندما قمت بإعداد الرسالة العلمية كأحد متطلبات نيل درجة الدكتوراه في الهندسة الإنشائية (هندسة تشييد وإدارة مشروعات).

والاقرار بحدثة موضوع الدراسة البحثية وانه لم يسبق تناول الموضوع والعناوين البحثية بصورته النهائية الكاملة او نشره سابقا في أي رسائل او أطاريح او كتب او أبحاث او أي منشورات علمية وذلك بما ينسجم مع الأمانة العلمية المتعارف عليها في كتابة الرسائل والأطاريح العلمية.
وقد تم قبول عدد (1) بحث للنشر بعنوان:

Visualized strategy for predicting buildings energy consumption during early design stage using parametric analysis

في مجلة علمية متخصصة في مجال الهندسة وهي:

Journal of Building Engineering

(ISSN: 2352-7102)

<https://www.journals.elsevier.com/journal-of-building-engineerin/>

<https://doi.org/10.1016/j.jobbe.2017.07.012>

وان الأبحاث المنشورة مستخرجة من الرسالة المذكورة بعلية وأن أسماء السادة المشرفين موجودة على البحث.

وهذا إقرار منى بذلك

المقر بما فيه

مهندس/ حسام الدين وفقى على



الإدارة العامة للمكتبات

مستخلص رسالة () مكتبات

الكلية:	الهندسة	القسم العلمي:	الهندسة الانشائية	الرقم:	
الاسم:	حسام الدين وقي على السيد	الدرجة العلمية:	الدكتوراه الفلسفية	التاريخ:	

عنوان الرسالة | التصميم المبني للمباني المستدامة باعتبار استهلاك الطاقة باستخدام المحاكاة والشبكات العصبية الاصطناعية

المستخلص

حديثاً، هناك مستوى عالٍ من الطلب على تصميم وبناء المباني المستدامة وذلك نظراً لارتفاع أسعار الطاقة وزيادة المخاوف البيئية المستمرة. لذا من المهم تقييم استهلاك الطاقة في المباني لأنها تعتبر مفتاح حل مشكلة توفير الطاقة. ونظراً لمحدودية أدوات المحاكاة المتاحة خلال مراحل التصميم الأولية والتي تتوافق مع الأجواء الحارة مثل مصر، تقترح هذه الدراسة استراتيجية تسهل عملية اتخاذ القرار فيما يخص تقدير استهلاك الطاقة خلال مرحلة التصميم الأولية ومن ثم الوصول إلى التصميم الأمثل الذي يحقق أقل استهلاك للطاقة. تم استخدام برامج التصميم البارومتري وبرامج نمذجة ومحاكاة الطاقة لإنشاء نموذج مبني سكني كوسيلة لإنشاء قاعدة بيانات لاستهلاك الطاقة. ومن ثم تم استخدام الشبكات العصبية الاصطناعية لبناء نموذج يمكن استخدامه للتنبؤ باستهلاك الطاقة للمباني السكنية في القاهرة الجديدة. أخيراً تم ربط الشبكات العصبية بالخوارزميات الجينية للبحث عن الخيار الأمثل من مجموعة حلول متوفرة لتصميم معين.

تقع الرسالة في (ثمانية) أبواب، وفيما يلي نبذة مختصرة عن محتويات أبواب الرسالة

- **الباب الأول:** ويعرض أهداف البحث ومنهجية الدراسة وكذلك عرض لمحتويات الرسالة.
- **الباب الثاني:** استعراض التعريفات المختلفة للمباني المستدامة وطرق تصميم المباني المستدامة والشبكات العصبية الاصطناعية ونظرية الخوارزميات الجينية واستعراض الباحث الأبحاث السابقة في مجال موضوع الرسالة.
- **الباب الثالث:** يعرض هذا الفصل دور نمذجة الطاقة خلال مراحل التصميم الأولية وطرق حسابات الطاقة بالمباني السكنية وتم عرض العوامل المؤثرة على استهلاك الطاقة كما تم عرض البرامج المستخدمة في نمذجة الطاقة وعرض مميزاتاها.
- **الباب الرابع:** وفيه تم استخدام برنامج (Rhino/Grasshopper) لبناء نموذج لمبنى سكني في مراحل التصميم الأولية وربطه ببرنامح محاكاة الطاقة (EnergyPlus) من خلال احدى تطبيقات (Grasshopper) ويسمى (Diva) والذي يستخدم في تعريف العوامل المؤثرة على نمذجة محاكاة الطاقة وتم انشاء قاعدة بيانات لاستهلاك الطاقة.
- **الباب الخامس:** وفيه تم استخدام قاعدة البيانات لإنشاء نموذج يستخدم الشبكات العصبية الاصطناعية للتنبؤ باستهلاك الطاقة وفيه أيضاً تم تطوير برنامج بالحاسب الآلي لتطبيق الإطار المقترح للتنبؤ باستهلاك الطاقة.
- **الباب السادس:** ويعرض نظرية الخوارزميات الجينية وقدرتها العالية للوصول إلى الخيار الأمثل من مجموعة حلول متوفرة حيث أنها تعتبر أشهر طرق الاستمثال والبحث والتي تستخدم تكنولوجيا مستوحاة من البيولوجيا التطورية مثل التوريث والطفرات والتهجين والاختيار. كما أيضاً تم تطوير برنامج بالحاسب الآلي لتطبيق الإطار المقترح للوصول إلى التصميم الأمثل الذي يحقق أقل استهلاك للطاقة في المباني السكنية خلال مراحل التصميم المبني.
- **الباب السابع:** ويعرض دراسة لمشروع حقيقي بالتطبيق على البرنامج الذي تم تطويره بالفصلين الخامس والسادس. وذلك للتأكد من فعالية البرنامج الذي تم تطويره. ثم تم عمل استبيان بين المتخصصين في هذا المجال لمعرفة مدى إمكانية استخدام البرنامج وسهولة الاستخدام بالنسبة للعاملين بمجال تصميم المباني
- **الباب الثامن:** ملخص للرسالة ويعرض أهم الاستنتاجات التي تم التوصل إليها، كما يعرض التوصيات المقترحة للدراسات المستقبلية في مجال البحث.

الكلمات

Residential buildings, Energy Simulation, Conceptual design phase, Visualization, ANN, Optimization, Genetic Algorithms

General Adminstarion Library–Mansoura University– 60 Gomhoria street, Mansoura, Egypt.
Box 35516

URL: <http://www.mans.edu.eg>

Email: mucentrlib@mans.edu.eg



جامعة المنصورة
كلية الهندسة
قسم الهندسة الانشائية

التصميم المبدئي للمباني المستدامة باعتبار استهلاك الطاقة باستخدام المحاكاة والشبكات العصبية الاصطناعية

رسالة
مقدمة كجزء من المتطلبات للحصول على درجة
دكتوراه الفلسفة
في
الهندسة الانشائية (هندسة تشييد وإدارة مشروعات)

مقدمة من

حسام الدين وفتي على

إشراف

الأستاذ الدكتور
سعد الدين مصطفى عبد ربه
قسم الهندسة الانشائية
كلية الهندسة – جامعة المنصورة

الدكتور
أحمد رمزي عباس
قسم هندسة القوى الميكانيكية
كلية الهندسة – جامعة المنصورة

الأستاذ الدكتور
عماد السعيد البلتاجي
قسم الهندسة الانشائية
كلية الهندسة – جامعة المنصورة

الدكتور
محمود حسيني داوود
قسم الهندسة الانشائية
كلية الهندسة – جامعة المنصورة